

CHE Series Sensorless Vector Control Inverter Operation Manual



- Thank you very much for your buying CHE series sensorless vector control inverter.
- Before use, please read this manual thoroughly to ensure proper usage. Keep this manual at an easily accessible place so that can refer anytime as necessary.

Safety Precautions

Please read this operation manual carefully before installation, operation, maintenance or inspection

In this manual, the safety precautions were sorted to "WARNING" or "CAUTION".



WARNING

Indicates a potentially dangerous situation which, if can not avoid will result in death or serious injury.



CAUTION

Indicates a potentially dangerous situation which, if can not avoid will cause minor or moderate injury and damage the device. This

Symbol is also used for warning any un-safety operation.

In some cases, even the contents of "CAUTION" still can cause serious accident. Please follow these important precautions in any situation

★ **NOTE** indicate the necessary operation to ensure the device run properly.

Warning Marks are placed on the front cover of the inverter.

Please follow these indications when using the inverter.

| WARNING | |
|---|--|
| <ul style="list-style-type: none">● May cause injury or electric shock.● Please follow the instructions in the manual before installation or operation.● Disconnect all power line before opening front cover of unit. Wait at least 1 minute until DC Bus capacitors discharge.● Use proper grounding techniques.● Never connect AC power to output UVW terminals | |

TABLE OF CONTENTS

| | |
|--|-----------|
| TABLE OF CONTENTS | II |
| LIST OF FIGURES | IV |
| 1. INTRODUCTION | 1 |
| 1.1 Technology Features | 1 |
| 1.2 Description of Name Plate | 2 |
| 1.3 Selection Guide | 2 |
| 1.4 Parts Description | 4 |
| 1.5 External Dimension | 5 |
| 2. INSPECTION | 8 |
| 3. INSTALLATION | 9 |
| 3.1 Environmental Requirement | 10 |
| 3.2 Installation Space | 11 |
| 3.3 Dimension of External Keypad | 12 |
| 3.4 Disassembly | 12 |
| 4. WIRING | 14 |
| 4.1 Connection of Peripheral Devices | 15 |
| 4.2 Terminal Configuration | 16 |
| 4.2.1 Main Circuit Terminals | 16 |
| 4.2.2 Control Circuit Terminals | 17 |
| 4.3 Typical Wiring Diagram | 18 |
| 4.4 Specifications of Breaker, Cable, Contactor and Reactor | 19 |
| 4.4.1 Specifications of breaker, cable and contactor | 19 |
| 4.4.2 Specifications of AC input reactor, AC output reactor and DC reactor | 21 |
| 4.4.3 Specification of braking resistor | 22 |
| 4.5 Wiring Main Circuits | 23 |
| 4.5.1 Wiring at input side of main circuit | 23 |
| 4.5.2 Wiring at inverter side of main circuit | 23 |
| 4.5.3 Wiring at motor side of main circuit | 24 |
| 4.5.4 Wiring of regenerative unit | 24 |
| 4.5.5 Wiring of Common DC bus | 25 |
| 4.5.6 Ground Wiring (PE) | 26 |
| 4.6 Wiring Control Circuits | 26 |
| 4.6.1 Precautions | 26 |
| 4.6.2 Control circuit terminals | 26 |
| 4.6.3 Jumpers on control board | 27 |
| 4.6.4 Wiring description of size A (1AC 0.4~0.75kW) | 27 |
| 4.7 Installation Guideline to EMC Compliance | 28 |
| 4.7.1 General description of EMC | 28 |
| 4.7.2 EMC features of inverter | 28 |
| 4.7.3 EMC Installation Guideline | 29 |
| 5. OPERATION | 32 |
| 5.1 Keypad Description | 32 |
| 5.1.1 Keypad schematic diagram | 32 |
| 5.1.2 Key function description | 32 |
| 5.1.3 Indicator light description | 33 |
| 5.2 Operation Process | 34 |

| | |
|--|------------|
| 5.2.1 Parameter setting | 34 |
| 5.2.2 Fault reset | 35 |
| 5.2.3 Motor parameter autotuning | 35 |
| 5.2.4 Password setting | 36 |
| 5.3 Running State | 36 |
| 5.3.1 Power-on initialization | 36 |
| 5.3.2 Stand-by | 36 |
| 5.3.3 Motor parameter autotuning | 36 |
| 5.3.4 Operation | 36 |
| 5.3.5 Fault | 36 |
| 5.4 Quick Testing | 37 |
| 6. DETAILED FUNCTION DESCRIPTION..... | 38 |
| 6.1 P0 Group--Basic Function | 38 |
| 6.2 P1 Group--Start and Stop Control..... | 45 |
| 6.3 P2 Group--Motor Parameters | 47 |
| 6.4 P3 Group--Vector Control | 49 |
| 6.5 P4 Group-- V/F Control | 50 |
| 6.6 P5 Group--Input Terminals..... | 52 |
| 6.7 P6 Group--Output Terminals | 57 |
| 6.8 P7 Group--Display Interface | 59 |
| 6.9 P8 Group--Enhanced Function..... | 63 |
| 6.10 P9 Group--PID Control | 67 |
| 6.11 PA Group-- Multi-step Speed Control..... | 71 |
| 6.12 PB Group-- Protection Function | 72 |
| 6.13 PC Group--Serial Communication | 75 |
| 6.14 PD Group--Supplementary Function | 78 |
| 6.15 PE Group--Factory Setting | 80 |
| 7. TROUBLE SHOOTING | 81 |
| 7.1 Fault and Trouble shooting | 81 |
| 7.2 Common Faults and Solutions..... | 83 |
| 8. MAINTENANCE | 84 |
| 8.1 Daily Maintenance | 84 |
| 8.2 Periodic Maintenance | 85 |
| 8.3 Replacement of wearing parts | 86 |
| 8.4 Warranty..... | 86 |
| 9. LIST OF FUNCTION PARAMETERS | 87 |
| Special parameter for CHE150 series high speed inverter: | 100 |
| Parameters display on LCD keypad | 101 |
| 10. COMMUNICATION PROTOCOL..... | 107 |

LIST OF FIGURES

| | |
|--|----|
| Figure 1.1 Nameplate of inverter..... | 2 |
| Figure 1.2 Parts of inverters (15kw and below)..... | 4 |
| Figure 1.3 Parts of inverters (18.5kw and above). | 5 |
| Figure 1.4 Dimension (0.4~0.75kW 1AC 220V). | 5 |
| Figure 1.5 Dimension (0.75~15kW). | 6 |
| Figure 1.6 Dimension (18.5~110kW). | 6 |
| Figure 1.7 Dimension (132~315kW). | 6 |
| Figure 1.8 Dimension (350~630kW). | 7 |
| Figure 3.1 Relationship between output current and altitude..... | 10 |
| Figure 3.2 Safe space..... | 11 |
| Figure 3.3 Installation of multiple inverters..... | 11 |
| Figure 3.4 Dimension of small keypad..... | 12 |
| Figure 3.5 Dimension of big keypad..... | 12 |
| Figure 3.6 Disassembly of plastic cover..... | 12 |
| Figure 3.7 Disassembly of metal plate cover. | 13 |
| Figure 3.8 Open inverter cabinet..... | 13 |
| Figure 4.1 Connection of peripheral devices..... | 15 |
| Figure 4.2 Main circuit terminals (0.4~0.75kW 1AC 220V). | 16 |
| Figure 4.3 Main circuit terminals (1.5~2.2kW)..... | 16 |
| Figure 4.4 Main circuit terminals (4.0~5.5kW)..... | 16 |
| Figure 4.5 Main circuit terminals (7.5~15kW)..... | 16 |
| Figure 4.6 Main circuit terminals (18.5~110kW)..... | 16 |
| Figure 4.7 Main circuit terminals (132~315kW)..... | 16 |
| Figure 4.8 Main circuit terminals (350~630kW)..... | 16 |
| Figure 4.9 Control circuit terminals (0.4~0.75kW 1AC 220V). | 17 |
| Figure 4.10 Control circuit terminals (1.5~2.2kW)..... | 17 |
| Figure 4.11 Control terminals (4.0kW and above). | 17 |
| Figure 4.12 Wiring diagram..... | 18 |
| Figure 4.13 Wiring at input side of main circuit. | 23 |
| Figure 4.14 Wiring at motor side of main circuit..... | 24 |
| Figure 4.15 Wiring of regenerative unit..... | 25 |
| Figure 4.16 Wiring of common DC bus..... | 25 |

| | |
|---|----|
| Figure 4.17 Wiring of size A (0.4~0.75kW 1AC). | 27 |
| Figure 5.1 Keypad schematic diagram. | 32 |
| Figure 5.2 Flow chart of parameter setting. | 34 |
| Figure 5.3 Quick testing. | 37 |
| Figure 6.1 Acceleration and deceleration time. | 41 |
| Figure 6.2 Effect of carrier frequency. | 42 |
| Figure 6.3 Starting diagram. | 45 |
| Figure 6.4 DC braking diagram. | 46 |
| Figure 6.5 FWD/REV dead time diagram. | 47 |
| Figure 6.6 ASR diagram. | 49 |
| Figure 6.7 PI parameter diagram. | 49 |
| Figure 6.8 V/F curve diagram. | 50 |
| Figure 6.9 Manual torque boost diagram. | 51 |
| Figure 6.10 2-wire control mode1. | 54 |
| Figure 6.11 2-wire control mode 2. | 55 |
| Figure 6.12 3-wire control mode 1. | 55 |
| Figure 6.13 3-wire control mode2. | 55 |
| Figure 6.14 Relationship between AI and corresponding setting. | 56 |
| Figure 6.15 Relationship between AO and corresponding setting. | 59 |
| Figure 6.16 Skip frequency diagram. | 64 |
| Figure 6.17 Traverse operation diagram. | 65 |
| Figure 6.18 FDT level and lag diagram. | 66 |
| Figure 6.19 Frequency arriving signal diagram. | 66 |
| Figure 6.20 PID control diagram. | 67 |
| Figure 6.21 Reducing overshooting diagram. | 69 |
| Figure 6.22 Rapidly stabilizing diagram. | 69 |
| Figure 6.23 Reducing long-cycle oscillation diagram. | 69 |
| Figure 6.24 Reducing short-cycle oscillation diagram. | 70 |
| Figure 6.25 Relationship between bias limit and output frequency. | 70 |
| Figure 6.26 Multi-steps speed operating diagram. | 72 |
| Figure 6.27 Motor overload protection curve. | 73 |
| Figure 6.28 Over-voltage stall function. | 74 |
| Figure 6.29 Current limiting protection function. | 75 |
| Figure 6.30 Meaning of PC.06. | 77 |

1. INTRODUCTION

1.1 Technology Features

• Input & Output

- ◆ Input Voltage Range: 380/220V \pm 15%
- ◆ Input Frequency Range: 47~63Hz
- ◆ Output Voltage Range: 0~rated input voltage
- ◆ Output Frequency Range: 0~600Hz

• I/O features

- ◆ Programmable Digital Input:
Provide 4 terminals which can accept ON-OFF inputs
- ◆ Programmable Analog Input:
AI1 can accept input of 0 ~10V; AI2 can accept input of 0~10V or 0~20mA.
- ◆ Programmable Open Collector Output:
Provide 1 output terminal (open collector output or high-speed pulse output)
- ◆ Relay Output: Provide 1 output terminal.
- ◆ Analog Output: Provide 1 analog output terminal, whose output scope can be 0/4~20 mA or 0~10 V, as chosen..

• Main Control Function

- ◆ Control Mode: Sensorless Vector Control (SVC), V/F Control.
- ◆ Overload Capacity:
60s with 150% of rated current, 10s with 180% of rated current.
- ◆ Starting Torque: 150% of rated torque at 0.5Hz (SVC).
- ◆ Speed Adjusting Range: 1:100 (SVC)
- ◆ Speed Accuracy: \pm 0.5% of maximum speed (SVC)
- ◆ Carrier Frequency: 0.5kHz ~15.0kHz.
- ◆ Reference Frequency Source: keypad, analog input, serial communication, multi-step speed, PID and so on. The combination of multi- modes and switching between different modes can be realized.
- ◆ Torque Control Function: Provide multiple torque setting source.
- ◆ PID Control Function
- ◆ Multi-Step Speed Control Function: 8 steps speed can be set.
- ◆ Traverse Control Function
- ◆ None-Stop when instantaneous power off.
- ◆ Speed trace Function: Start the running motor smoothly.
- ◆ QUICK/JOG Key: User defined shortcut key can be realized.
- ◆ Automatic Voltage Regulation (AVR) Function:
Automatically keep the output voltage stable when input voltage fluctuating.
- ◆ Up to 24 fault protections:
Protect from over current, over voltage, under voltage, over heat, phase failure, over load etc.

1.2 Description of Name Plate

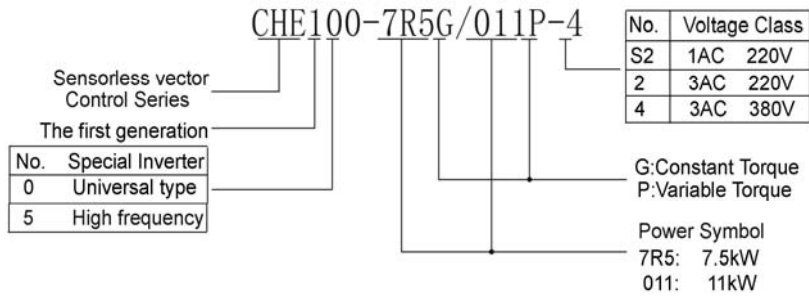

Figure 1.1 Nameplate of inverter.

1.3 Selection Guide

| Model No. | Rated Output Power (kW) | Rated Input current (A) | Rated Output current (A) | Motor Power (KW) | Size |
|--------------------------|-------------------------|-------------------------|--------------------------|------------------|------|
| 1AC 220V -15%~15% | | | | | |
| CHE100-0R4G-S2 | 0.4 | 5.4 | 2.3 | 0.4 | A |
| CHE100-0R7G-S2 | 0.75 | 8.2 | 4.5 | 0.75 | A |
| CHE100-1R5G-S2 | 1.5 | 14.2 | 7.0 | 1.5 | B |
| CHE100-2R2G-S2 | 2.2 | 23.0 | 10 | 2.2 | B |
| 3AC 220V -15%~15% | | | | | |
| CHE100-0R7G-2 | 0.75 | 5.0 | 4.5 | 0.75 | A |
| CHE100-1R5G-2 | 1.5 | 7.7 | 7 | 1.5 | B |
| CHE100-2R2G-2 | 2.2 | 11.0 | 10 | 2.2 | B |
| CHE100-004G-2 | 3.7 | 17.0 | 16 | 3.7 | D |
| CHE100-5R5G-2 | 5.5 | 21.0 | 20 | 5.5 | D |
| CHE100-7R5G-2 | 7.5 | 31.0 | 30 | 7.5 | E |
| CHE100-011G-2 | 11.0 | 43.0 | 42 | 11.0 | E |
| CHE100-015G-2 | 15.0 | 56.0 | 55 | 15.0 | E |
| CHE100-018G-2 | 18.5 | 71.0 | 70 | 18.5 | F |
| CHE100-022G-2 | 22.0 | 81.0 | 80 | 22.0 | F |
| CHE100-030G-2 | 30.0 | 112.0 | 110 | 30.0 | F |
| CHE100-037G-2 | 37.0 | 132.0 | 130 | 37.0 | G |
| CHE100-045G-2 | 45.0 | 163.0 | 160 | 45.0 | G |

| 3AC 380V -15%~15% | | | | | |
|--------------------|----------|----------|----------|----------|---|
| CHE100-0R7G-4 | 0.75 | 3.4 | 2.5 | 0.75 | B |
| CHE100-1R5G-4 | 1.5 | 5.0 | 3.7 | 1.5 | B |
| CHE100-2R2G-4 | 2.2 | 5.8 | 5 | 2.2 | B |
| CHE100-004G/5R5P-4 | 4.0/5.5 | 10/15 | 9/13 | 4.0/5.5 | C |
| CHE100-5R5G/7R5P-4 | 5.5/7.5 | 15/20 | 13/17 | 5.5/7.5 | C |
| CHE100-7R5G/011P-4 | 7.5/11 | 20/26 | 17/25 | 7.5/11 | D |
| CHE100-011G/015P-4 | 11/15 | 26/35 | 25/32 | 11/15 | D |
| CHE100-015G/018P-4 | 15/ 18.5 | 35/38 | 32/37 | 15/ 18.5 | D |
| CHE100-018G/022P-4 | 18.5/ 22 | 38/46 | 37/45 | 18.5/ 22 | E |
| CHE100-022G/030P-4 | 22/30 | 46/62 | 45/60 | 22/30 | E |
| CHE100-030G/037P-4 | 30/37 | 62/76 | 60/75 | 30/37 | E |
| CHE100-037G/045P-4 | 37/45 | 76/90 | 75/90 | 37/45 | F |
| CHE100-045G/055P-4 | 45/55 | 90/105 | 90/110 | 45/55 | F |
| CHE100-055G/075P-4 | 55/75 | 105/ 140 | 110/ 150 | 55/75 | F |
| CHE100-075G/090P-4 | 75/90 | 140/ 160 | 150/ 176 | 75/90 | G |
| CHE100-090G/110P-4 | 90/110 | 160/ 210 | 176/ 210 | 90/110 | G |
| CHE100-110G/132P-4 | 110/132 | 210/ 240 | 210/ 250 | 110/132 | G |
| CHE100-132G/160P-4 | 132/160 | 240/ 290 | 250/ 300 | 132/160 | H |
| CHE100-160G/185P-4 | 160/185 | 290/ 330 | 300/ 340 | 160/185 | H |
| CHE100-185G/200P-4 | 185/200 | 330/ 370 | 340/ 380 | 185/200 | H |
| CHE100-200G/220P-4 | 200/220 | 370/ 410 | 380/ 415 | 200/220 | I |
| CHE100-220G/250P-4 | 220/250 | 410/ 460 | 415/ 470 | 220/250 | I |
| CHE100-250G/280P-4 | 250/280 | 460/ 500 | 470/ 520 | 250/280 | I |
| CHE100-280G/315P-4 | 280/315 | 500/ 580 | 520/ 600 | 280/315 | I |
| CHE100-315G/350P-4 | 315/350 | 580/ 620 | 600/ 640 | 315/350 | I |
| CHE100-350G-4 | 350 | 620 | 640 | 350 | J |
| CHE100-400G-4 | 400 | 670 | 690 | 400 | J |
| CHE100-500G-4 | 500 | 835 | 860 | 500 | J |
| CHE100-560G-4 | 560 | 920 | 950 | 560 | J |
| CHE100-630G-4 | 630 | 1050 | 1100 | 630 | J |

1.4 Parts Description

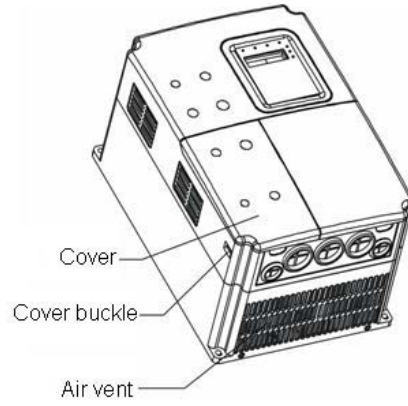
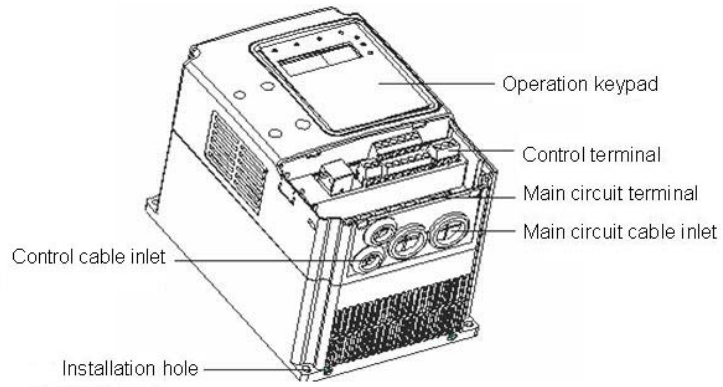

Figure 1.2 Parts of inverters (15kw and below).

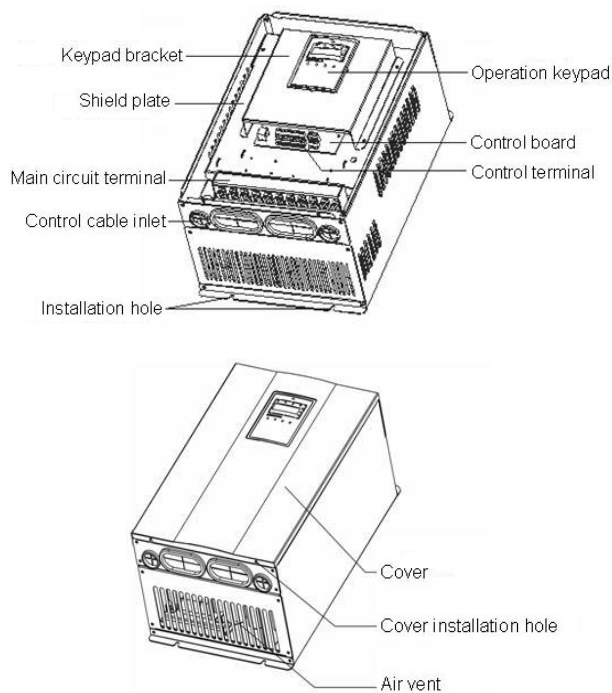

Figure 1.3 Parts of inverters (18.5kw and above).

1.5 External Dimension

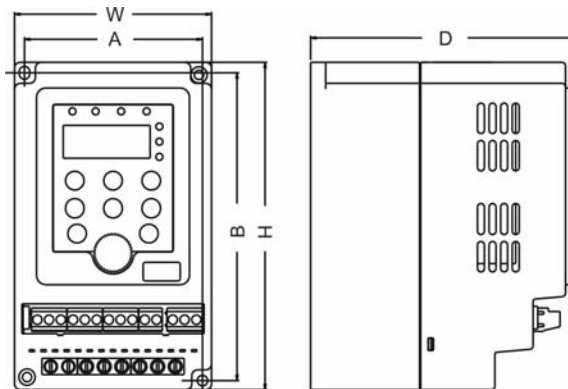

Figure 1.4 Dimension (0.4~0.75kW 1AC 220V).

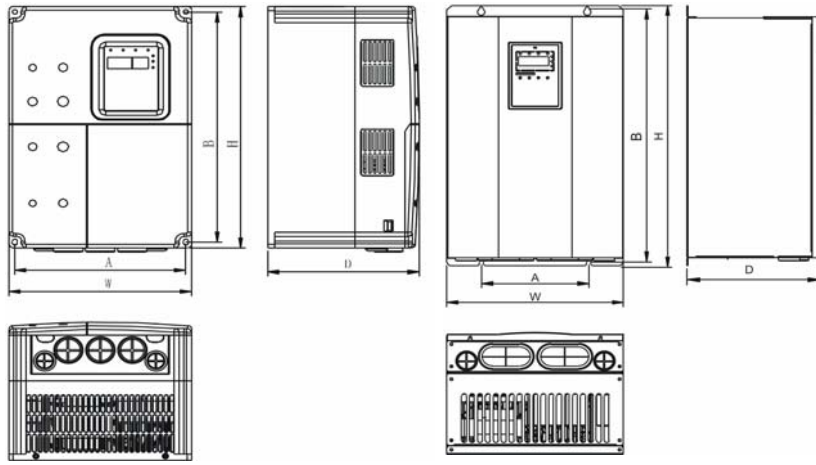

Figure 1.5 Dimension (0.75~15kW).

Figure 1.6 Dimension (18.5~110kW).

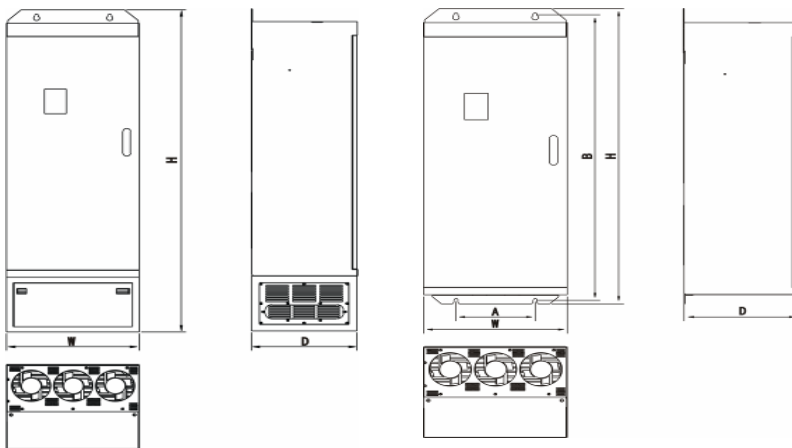

Figure 1.7 Dimension (132~315kW).

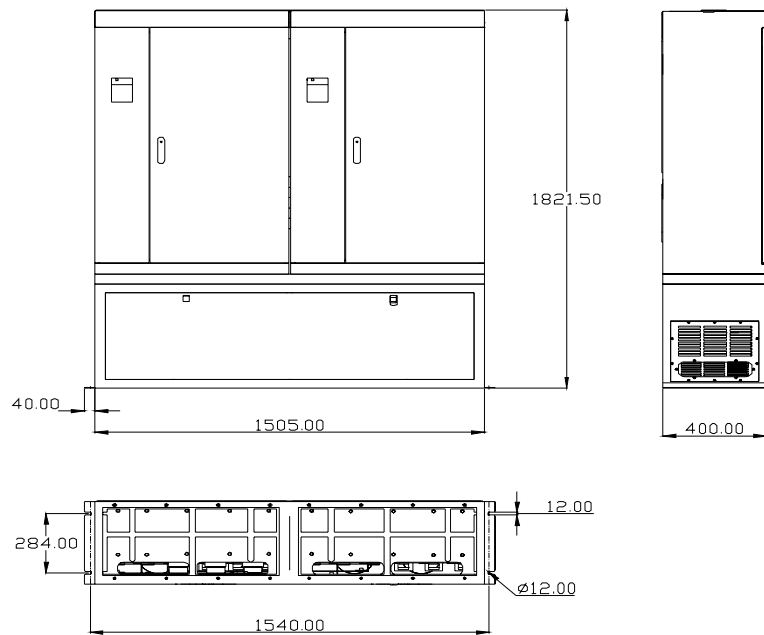

Figure 1.8 Dimension (350~630kW).

2. INSPECTION



CAUTION

- **Don't install or use any inverter that is damaged or have fault part, otherwise may cause injury.**

Check the following items when unpacking the inverter,

1. Inspect the entire exterior of the Inverter to ensure there are no scratches or other damage caused by the transportation.
2. Ensure there is operation manual and warranty card in the packing box.
3. Inspect the nameplate and ensure it is what you ordered.
4. Ensure the optional parts are what you need if have ordered any optional parts.

Please contact the local agent if there is any damage in the inverter or optional parts.

3. INSTALLATION



WARNING

- The person without passing the training manipulate the device or any rule in the “Warning” being violated, will cause severe injury or property loss. Only the person, who has passed the training on the design, installation, commissioning and operation of the device and gotten the certification, is permitted to operate this equipment.
- Input power cable must be connected tightly, and the equipment must be grounded securely.
- Even if the inverter is not running, the following terminals still have dangerous voltage:
 - Power Terminals: R, S, T
 - Motor Connection Terminals: U, V, W.
- When power off, should not install the inverter until 5 minutes after, which can ensure the device discharge completely.
- The section area of grounding conductor must be no less than that of power supply cable.



CAUTION

- When moving the inverter please lift by its base and don't lift by the panel. Otherwise may cause the main unit fall off which may result in personal injury.
- Install the inverter on the fireproofing material (such as metal) to prevent fire.
- When need install two or more inverters in one cabinet, cooling fan should be provided to make sure that the air temperature is lower than 45°C. Otherwise it could cause fire or damage the device.

3.1 Environmental Requirement

1. Temperature

Environment temperature range: $-10^{\circ}\text{C} \sim +40^{\circ}\text{C}$. Inverter will be derated if ambient temperature exceeds 40°C .

2. Humidity

Less than 95% RH, without dewfall.

3. Altitude

Inverter can output the rated power when installed with altitude of lower than 1000m. It will be derated when the altitude is higher than 1000m. For details, please refer to the following figure:

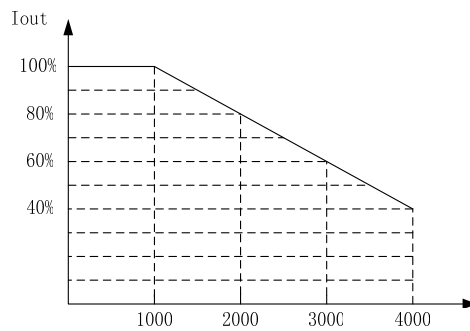

Figure 3.1 Relationship between output current and altitude.

4. Impact and Vibration

It is not allowed that the inverter falls down or suffers from fierce impact or the inverter installed at the place that vibration frequently.

5. Electromagnetic Radiation

Keep away from the electromagnetic radiation source.

6. Water

Do not install the inverter at the wringing or dewfall place.

7. Air Pollution

Keep away from air pollution such as dusty, corrosive gas.

8. Storage

Do not store the inverter in the environment with direct sunlight, vapor, oil fog and vibration.

3.2 Installation Space

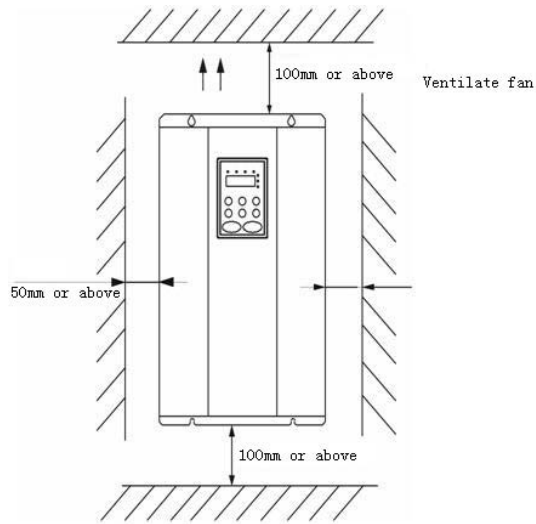

Figure 3.2 Safe space.

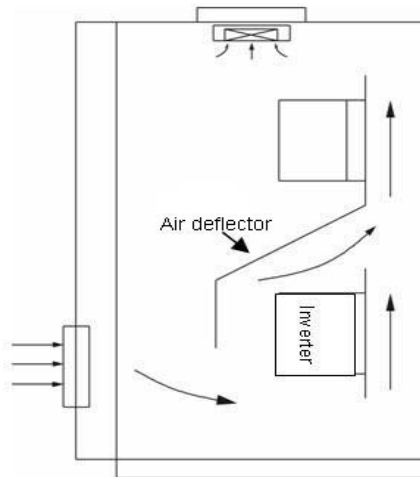

Figure 3.3 Installation of multiple inverters.

Notice: Add the air deflector when apply the up-down installation.

3.3 Dimension of External Keypad

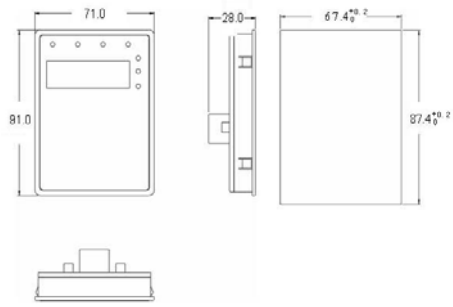

Figure 3.4 Dimension of small keypad.

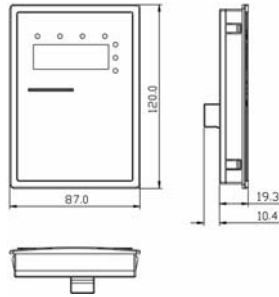

Figure 3.5 Dimension of big keypad.

3.4 Disassembly

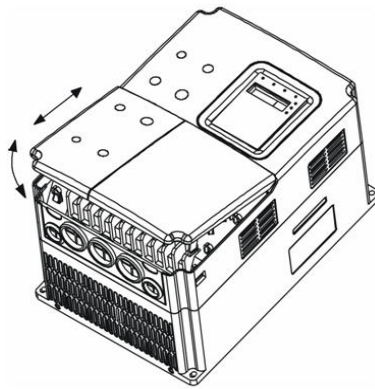

Figure 3.6 Disassembly of plastic cover.

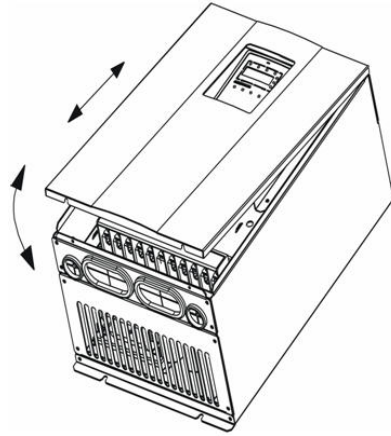

Figure 3.7 Disassembly of metal plate cover.

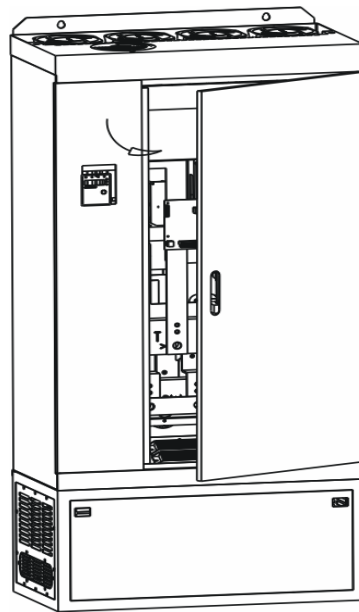

Figure 3.8 Open inverter cabinet.

4. WIRING



WARNING

- Wiring must be performed by the person certified in electrical work.
- Forbid testing the insulation of cable that connects the inverter with high-voltage insulation testing devices.
- Cannot install the inverter until discharged completely after the power supply is switched off for 5 minutes.
- Be sure to ground the ground terminal.
(200V class: Ground resistance should be 100Ω or less, 400V class: Ground resistance should be 10Ω or less, 660V class: Ground resistance should be 5Ω or less). Otherwise, it might cause electric shock or fire.
- Connect input terminals (R, S, T) and output terminals (U, V, W) correctly.
Otherwise it will cause damage the inside part of inverter.
- Do not wire and operate the inverter with wet hands.
Otherwise there is a risk of electric shock.



CAUTION

- Check to be sure that the voltage of the main AC power supply satisfies the rated voltage of the Inverter.
Injury or fire can occur if the voltage is not correct.
- Connect power supply cables and motor cables tightly.

4.1 Connection of Peripheral Devices

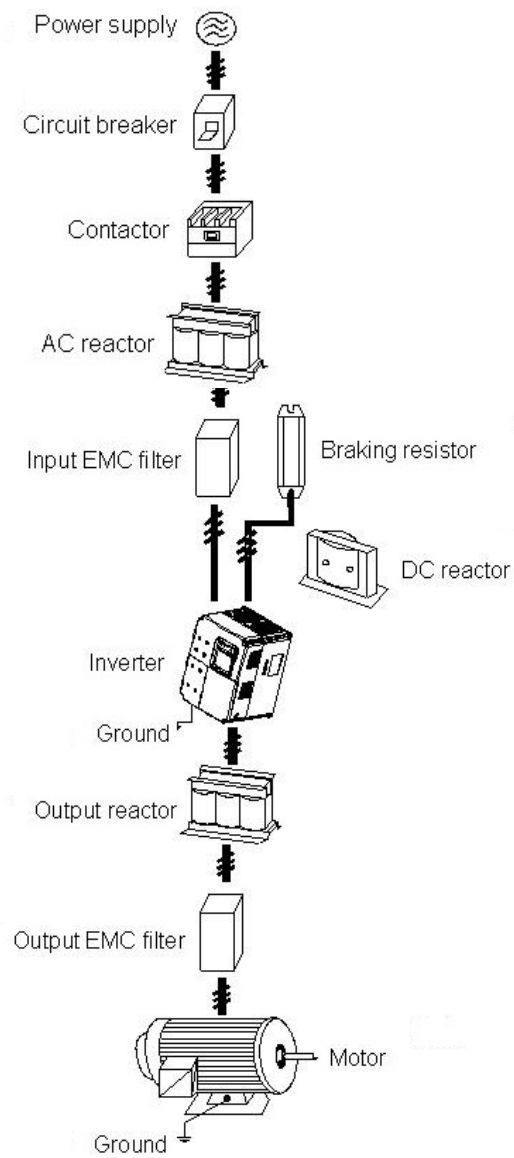

Figure 4.1 Connection of peripheral devices.

4.2 Terminal Configuration

4.2.1 Main Circuit Terminals



Figure 4.2 Main circuit terminals (0.4~0.75kW 1AC 220V).

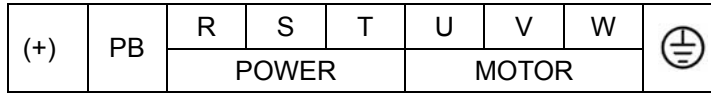

Figure 4.3 Main circuit terminals (1.5~2.2kW).

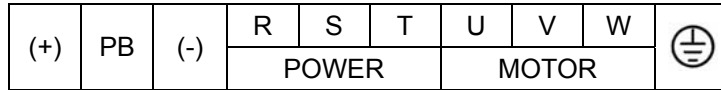

Figure 4.4 Main circuit terminals (4.0~5.5kW) .

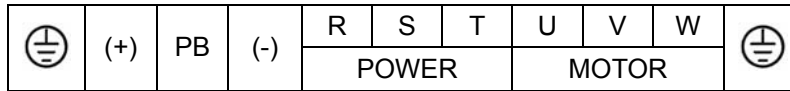

Figure 4.5 Main circuit terminals (7.5~15kW).

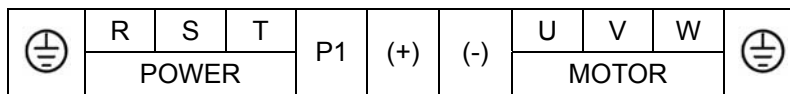

Figure 4.6 Main circuit terminals (18.5~110kW).

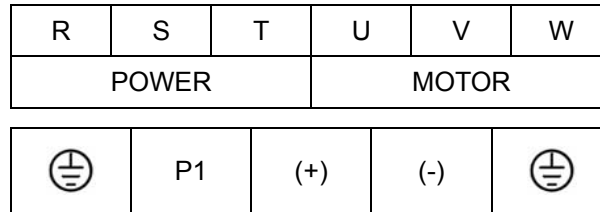

Figure 4.7 Main circuit terminals (132~315kW).

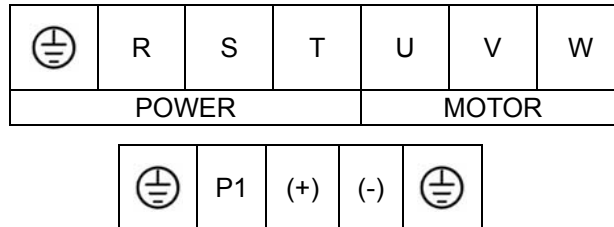



Figure 4.8 Main circuit terminals (350~630kW).

Main circuit terminal functions are summarized according to the terminal symbols in the following table. Wire the terminal correctly for the desired purposes.

| Terminal Symbol | Function Description |
|---|--|
| R、S、T | Terminals of 3 phase AC input |
| (+)、(-) | Spare terminals of external braking unit |
| (+)、PB | Spare terminals of external braking resistor |
| P1、(+) | Spare terminals of external DC reactor |
| (-) | Terminal of negative DC bus |
| U、V、W | Terminals of 3 phase AC output |
|  | Terminal of ground |

4.2.2 Control Circuit Terminals

| | | | | | | | | | | | | | |
|------|------|----|----|----|----|-----|-----|----|---|------|-----|-----|-----|
| 485+ | 485- | S1 | S2 | S3 | S4 | COM | AI2 | AO | Y | +24V | ROA | ROB | ROC |
|------|------|----|----|----|----|-----|-----|----|---|------|-----|-----|-----|

Figure 4.9 Control circuit terminals (0.4~0.75kW 1AC 220V).

| | | | | | | | | | |
|------|------|------|----|-----|----|------|-----|-----|-----|
| 485+ | 485- | +10V | AO | COM | Y | +24V | ROA | ROB | ROC |
| AI1 | GND | AI2 | S1 | S2 | S3 | S4 | | | |

Figure 4.10 Control circuit terminals (1.5~2.2kW).

| | | | | | | | | | | | | | | | | |
|------|------|----|-----|-----|-----|------|----|----|----|----|-----|---|------|-----|-----|-----|
| 485+ | 485- | AO | AI1 | GND | AI2 | +10V | S1 | S2 | S3 | S4 | COM | Y | +24V | ROA | ROB | ROC |
|------|------|----|-----|-----|-----|------|----|----|----|----|-----|---|------|-----|-----|-----|

Figure 4.11 Control terminals (4.0kW and above).

4.3 Typical Wiring Diagram

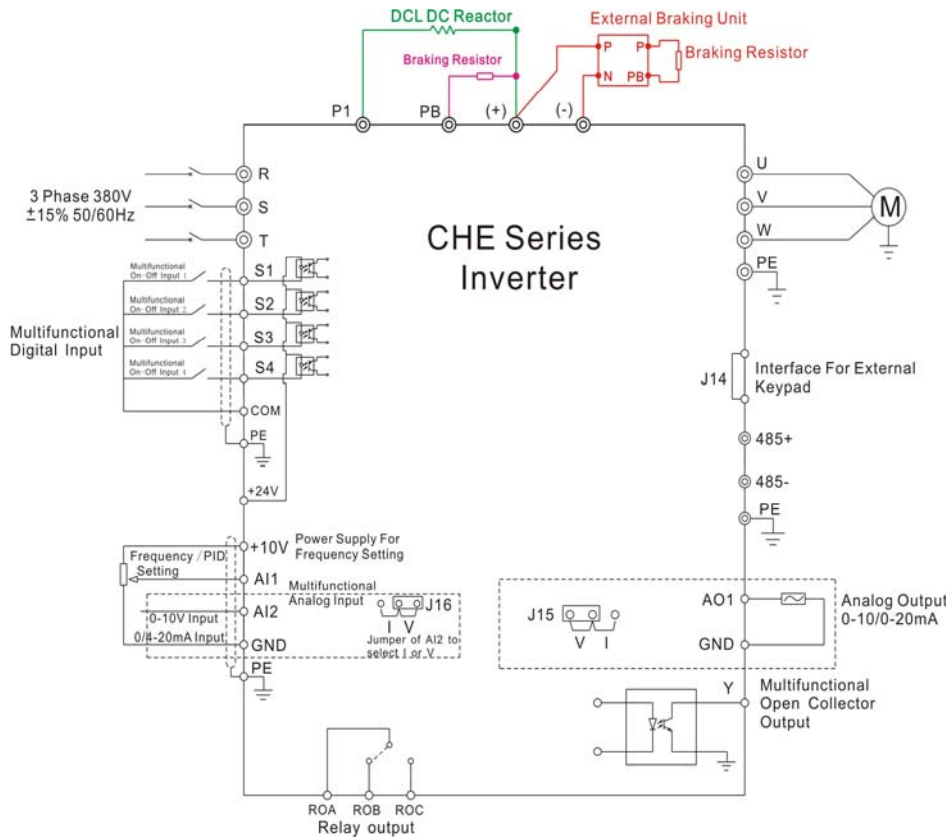

Figure4. 12 Wiring diagram.

Notice

1. Inverters between 18.5KW and 90KW have built-in DC reactor which is used to improve power factor. For inverters above 110KW, it is recommended to install DC reactor between P1 and (+).
2. Inverters below 15KW have built-in braking unit. If need braking, only need to install braking resistor between PB and (+).
3. For inverters above 18.5KW, if need braking, should install external braking unit between (+) and (-).

.4.4 Specifications of Breaker, Cable, Contactor and Reactor**4.4.1 Specifications of breaker, cable and contactor**

| Model No. | Circuit Breaker (A) | Input/Output Cable (mm ²) | Rated Current of Contactor (A) |
|------------------|---------------------|---------------------------------------|--------------------------------|
| 1AC 220V -15~15% | | | |
| CHE100-0R4G-S2 | 16 | 2.5 | 10 |
| CHE100-0R7G-S2 | 16 | 2.5 | 10 |
| CHE100-1R5G-S2 | 20 | 4 | 16 |
| CHE100-2R2G-S2 | 32 | 6 | 20 |
| 3AC 220V -15~15% | | | |
| CHE100-0R4G-2 | 16 | 2.5 | 10 |
| CHE100-0R7G-2 | 16 | 2.5 | 10 |
| CHE100-1R5G-2 | 20 | 4 | 16 |
| CHE100-2R2G-2 | 32 | 6 | 20 |
| CHE100-004G-2 | 40 | 6 | 25 |
| CHE100-5R5G-2 | 63 | 6 | 32 |
| CHE100-7R5G-2 | 100 | 10 | 63 |
| CHE100-011G-2 | 125 | 25 | 95 |
| CHE100-015G-2 | 160 | 25 | 120 |
| CHE100-018G-2 | 160 | 25 | 120 |
| CHE100-022G-2 | 200 | 35 | 170 |
| CHE100-030G-2 | 200 | 35 | 170 |
| CHE100-037G-2 | 200 | 35 | 170 |
| CHE100-045G-2 | 250 | 70 | 230 |

Wiring

| 3AC 380V -15~15% | | | |
|--------------------|------|-------|-----|
| CHE100-0R7G-4 | 10 | 2.5 | 10 |
| CHE100-1R5G-4 | 16 | 2.5 | 10 |
| CHE100-2R2G-4 | 16 | 2.5 | 10 |
| CHE100-004G/5R5P-4 | 25 | 4 | 16 |
| CHE100-5R5G/7R5P-4 | 25 | 4 | 16 |
| CHE100-7R5G/011P-4 | 40 | 6 | 25 |
| CHE100-011G/015P-4 | 63 | 6 | 32 |
| CHE100-015G/018P-4 | 63 | 6 | 50 |
| CHE100-018G/022P-4 | 100 | 10 | 63 |
| CHE100-022G/030P-4 | 100 | 16 | 80 |
| CHE100-030G/037P-4 | 125 | 25 | 95 |
| CHE100-037G/045P-4 | 160 | 25 | 120 |
| CHE100-045G/055P-4 | 200 | 35 | 135 |
| CHE100-055G/075P-4 | 200 | 35 | 170 |
| CHE100-075G/090P-4 | 250 | 70 | 230 |
| CHE100-090G/110P-4 | 315 | 70 | 280 |
| CHE100-110G/132P-4 | 400 | 95 | 315 |
| CHE100-132G/160P-4 | 400 | 150 | 380 |
| CHE100-160G/185P-4 | 630 | 185 | 450 |
| CHE100-185G/200P-4 | 630 | 185 | 500 |
| CHE100-220G/250P-4 | 800 | 150x2 | 630 |
| CHE100-250G/280P-4 | 800 | 150x2 | 700 |
| CHE100-280G/315P-4 | 1000 | 185x2 | 780 |
| CHE100-315G/350P-4 | 1200 | 240x2 | 900 |

4.4.2 Specifications of AC input reactor, AC output reactor and DC reactor

| Model No. | AC Input reactor | | AC Output reactor | | DC reactor | |
|--------------------|------------------|--------------------|-------------------|--------------------|----------------|--------------------|
| | Current (A) | Inductance (mH) | Current (A) | Inductance (mH) | Current (A) | Inductance (mH) |
| 3AC 380V -15~15% | | | | | | |
| CHE100-0R7G-4 | 2.0 | 7.00 | 2.0 | 2.0 | — | — |
| CHE100-1R5G-4 | 5.0 | 3.80 | 5.0 | 1.5 | — | — |
| CHE100-2R2G-4 | 7.5 | 2.50 | 7.5 | 1.0 | — | — |
| CHE100-004G/5R5P-4 | 10 | 1.50 | 10 | 0.6 | — | — |
| CHE100-5R5G/7R5P-4 | 15 | 1.00 | 15 | 0.250 | — | — |
| CHE100-7R5G/011P-4 | 20 | 0.75 | 20 | 0.130 | 23 | 3.5 |
| CHE100-011G/015P-4 | 30 | 0.60 | 30 | 0.087 | 33 | 2.4 |
| CHE100-015G/018P-4 | 40 | 0.42 | 40 | 0.066 | 33 | 1.8 |
| CHE100-018G/022P-4 | 50 | 0.35 | 50 | 0.052 | 40 | 1.5 |
| CHE100-022G/030P-4 | 60 | 0.28 | 60 | 0.045 | 50 | 1.5 |
| CHE100-030G/037P-4 | 80 | 0.19 | 80 | 0.032 | 65 | 1.0 |
| CHE100-037G/045P-4 | 90 | 0.16 | 90 | 0.030 | 80 | 0.60 |
| CHE100-045G/055P-4 | 120 | 0.13 | 120 | 0.023 | 120 | 0.48 |
| CHE100-055G/075P-4 | 150 | 0.10 | 150 | 0.019 | 150 | 0.32 |
| CHE100-075G/090P-4 | 200 | 0.08 | 200 | 0.014 | 200 | 0.25 |
| CHE100-090G/110P-4 | 200 | 0.08 | 200 | 0.014 | 250 | 0.16 |
| CHE100-110G/132P-4 | 250 | 0.06 | 250 | 0.011 | 300 | 0.2 |
| CHE100-132G/160P-4 | 250 | 0.06 | 250 | 0.011 | 300 | 0.2 |
| CHE100-160G/185P-4 | 330 | 0.04 | 330 | 0.008 | 360 | 0.17 |
| CHE100-185G/200P-4 | 390 | 0.04 | 390 | 0.005 | 450 | 0.15 |
| CHE100-200G/220P-4 | 390 | 0.04 | 390 | 0.005 | 450 | 0.15 |
| CHE100-220G/250P-4 | 490 | 0.03 | 490 | 0.004 | 450 | 0.15 |
| CHE100-250G/280P-4 | 490 | 0.03 | 490 | 0.004 | 650 | 0.072 |
| CHE100-280G/315P-4 | 660 | 0.02 | 660 | 0.002 | 650 | 0.072 |
| CHE100-315G/350P-4 | 660 | 0.02 | 660 | 0.002 | 800 | 0.062 |

4.4.3 Specification of braking resistor

| Model No. | Braking Resistor (100% of Braking torque) | |
|--------------------|---|----------|
| | Specifications | Quantity |
| 3AC 380V -15~15% | | |
| CHE100-0R7G-4 | 750Ω/80W | 1 |
| CHE100-1R5G-4 | 400Ω/260W | 1 |
| CHE100-2R2G-4 | 250Ω/260W | 1 |
| CHE100-004G/5R5P-4 | 150Ω/390W | 1 |
| CHE100-5R5G/7R5P-4 | 100Ω/520W | 1 |
| CHE100-7R5G/011P-4 | 75Ω/780W | 1 |
| CHE100-011G/015P-4 | 50Ω/1040W | 1 |
| CHE100-015G/018P-4 | 40Ω/1560W | 1 |
| CHE100-018G/022P-4 | 32Ω/4800W | 1 |
| CHE100-022G/030P-4 | 27.2Ω/4800W | 1 |
| CHE100-030G/037P-4 | 20Ω/6000W | 1 |
| CHE100-037G/045P-4 | 16Ω/9600W | 1 |
| CHE100-045G/055P-4 | 13.6Ω/9600W | 1 |
| CHE100-055G/075P-4 | 10Ω/12000W | 1 |
| CHE100-075G/090P-4 | 6.8Ω/12000W | 1 |
| CHE100-090G/110P-4 | 6.8Ω/12000W | 1 |
| CHE100-110G/132P-4 | 6Ω/20000W | 1 |
| CHE100-132G/160P-4 | 6Ω/20000W | 1 |
| CHE100-160G/185P-4 | 5Ω/25000W | 2 |
| CHE100-185G/200P-4 | 4Ω/30000W | 3 |
| CHE100-200G/220P-4 | 4Ω/30000W | 3 |
| CHE100-220G/250P-4 | 4Ω/30000W | 3 |
| CHE100-250G/280P-4 | 3Ω/40000W | 4 |
| CHE100-280G/315P-4 | 3Ω/40000W | 5 |
| CHE100-315G/350P-4 | 3Ω/40000W | 5 |
| CHE100-350G-4 | 3Ω/40000W | 5 |
| CHE100-400G-4 | 2Ω/50000W | 6 |
| CHE100-500G-4 | 2Ω/50000W | 6 |
| CHE100-560G-4 | 2Ω/50000W | 7 |
| CHE100-630G-4 | 2Ω/60000W | 7 |

4.5 Wiring Main Circuits

4.5.1 Wiring at input side of main circuit

1. Circuit breaker

It is necessary to connect a circuit breaker which is compatible with the capacity of inverter between 3ph AC power supply and power input terminals (R, S, T). The capacity of breaker is 1.5~2 times to the rated current of inverter. For details, see <Specifications of Breaker, Cable, and Contactor>.

2. Contactor

In order to cut off the input power effectively when something is wrong in the system, contactor should be installed at the input side to control the on/off of the main circuit power supply.

3. AC reactor

In order to prevent the rectifier damage resulted from the large current, AC reactor should be installed at the input side. It can also prevent rectifier from sudden variation of power voltage or harmonic generated by phase-control load.

4. Input EMC filter

The surrounding device may be disturbed by the cables when the inverter is working. EMC filter can minimize the interference. Just like the following figure.

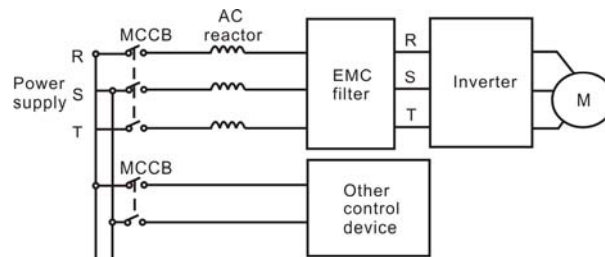

Figure 4.13 Wiring at input side of main circuit.

4.5.2 Wiring at inverter side of main circuit

1. DC reactor

Inverter from 18.5kW to 90kW have built-in DC reactor which can improve the power factor.

2. Braking unit and braking resistor

- Inverter of 15KW and below have built-in braking unit. In order to dissipate the regenerative energy generated by dynamic braking, the braking resistor should

be installed at (+) and PB terminals. The wire length of the braking resistor should be less than 5m.

- Inverter of 18.5KW and above need connect external braking unit which should be installed at (+) and (-) terminals. The cable between inverter and braking unit should be less than 5m. The cable between braking unit and braking resistor should be less than 10m.
- The temperature of braking resistor will increase because the regenerative energy will be transformed to heat. Safety protection and good ventilation is recommended.

Notice: Be sure that the electric polarity of (+) (-) terminals is right; it is not allowed to connect (+) with (-) terminals directly, otherwise damage or fire could occur.

4.5.3 Wiring at motor side of main circuit

1) Output Reactor

When the distance between inverter and motor is more than 50m, inverter may be tripped by over-current protection frequently because of the large leakage current resulted from the parasitic capacitance with ground. And the same time to avoid the damage of motor insulation, the output reactor should be installed.

2) Output EMC filter

EMC filter should be installed to minimize the leak current caused by the cable and minimize the radio noise caused by the cables between the inverter and cable.

Just see the following figure.

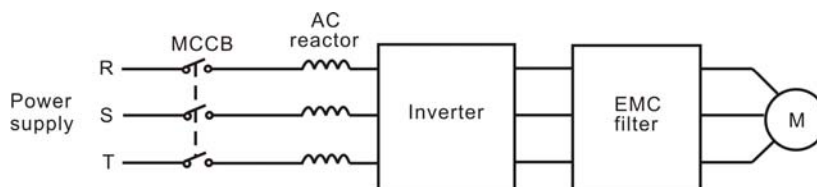

Figure 4.14 Wiring at motor side of main circuit.

4.5.4 Wiring of regenerative unit

Regenerative unit is used for putting the electricity generated by braking of motor to the grid. Compared with traditional 3 phase inverse parallel bridge type rectifier unit, regenerative unit uses IGBT so that the total harmonic distortion (THD) is less than 4%. Regenerative unit is widely used for centrifugal and hoisting equipment.

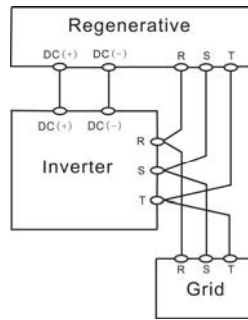

Figure 4.15 Wiring of regenerative unit.

4.5.5 Wiring of Common DC bus

Common DC bus method is widely used in the paper industry and chemical fiber industry which need multi-motor to coordinate. In these applications, some motors are in driving status while some others are in regenerative braking (generating electricity) status. The regenerated energy is automatically balanced through the common DC bus, which means it can supply to motors in driving status. Therefore the power consumption of whole system will be less compared with the traditional method (one inverter drives one motor). When two motors are running at the same time (i.e. winding application), one is in driving status and the other is in regenerative status. In this case the DC buses of these two inverters can be connected in parallel so that the regenerated energy can be supplied to motors in driving status whenever it needs. Detailed wiring is shown in the following figure:

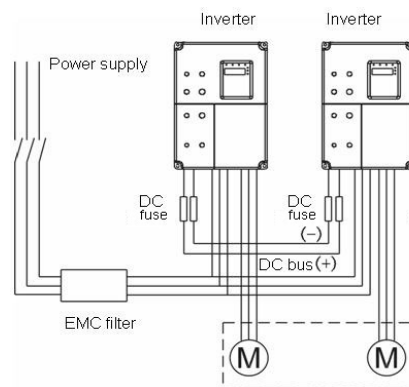

Figure 4.16 Wiring of common DC bus.

Notice: Two inverters must be the same model when connected with Common DC bus method. Be sure they are powered on at the same time.

4.5.6 Ground Wiring (PE)

In order to ensure safety and prevent electrical shock and fire, PE must be grounded with ground resistance. The ground wire should be big and short, and it is better to use copper wire ($>3.5\text{mm}^2$). When multiple inverters need to be grounded, do not loop the ground wire.

4.6 Wiring Control Circuits

4.6.1 Precautions

- Use shielded or twisted-pair cables to connect control terminals.
- Connect the ground terminal (PE) with shield wire.
- The cable connected to the control terminal should leave away from the main circuit and heavy current circuits (including power supply cable, motor cable, relay and contactor connecting cable) at least 20cm and parallel wiring should be avoided. It is suggested to apply perpendicular wiring to prevent inverter malfunction caused by external interference.

4.6.2 Control circuit terminals

| Terminal No. | Function |
|-----------------|--|
| S1~S4 | ON-OFF signal input, optical coupling with PW and COM. Input voltage range: 9~30V Input impedance: 3.3kΩ |
| +24V | Provide output power supply of +24V. Maximum output current: 150mA |
| AI1 | Analog input: 0~10V Input impedance: 10kΩ |
| AI2 | Analog input: 0~10V/ 0~20mA, switched by J16. Input impedance: 10kΩ (voltage input) / 250Ω (current input) |
| GND | Common ground terminal of analog signal and +10V. GND must be isolated from COM. |
| +10V | Supply +10V to inverter. |
| COM | Common ground terminal for digital signal and +24V (or external power supply). |
| AO | Provide voltage or current output which can be switched by J15. Output range: 0~10V/ 0~20mA |
| Y | Open collector output terminal, the corresponding common ground terminal is COM. |
| ROA、ROB、 ROC | Relay output: ROA--common; ROB--NC, ROC--NO. Contact capacity: AC 250V/3A, DC 30V/1A |

4.6.3 Jumpers on control board

| Jumper | Function |
|--------|--|
| J2, J4 | Default setting: J2 and J4 are disconnected. It is prohibited to be connected together, otherwise it will cause inverter malfunction. |
| J7 | Default setting: 2 and 3 connected. Do not change default setting otherwise it will cause communication malfunction. |
| J16 | Switch between (0~10V) voltage input and (0~20mA) current input. V connect to GND means voltage input; I connect to GND means current input. |
| J15 | Switch between (0~10V) voltage output and (0~20mA) current output. V connect to OUT means voltage output; I connect to OUT means current output. |

4.6.4 Wiring description of size A (1AC 0.4~0.75kW)

AI2 can work in three modes (0~24V/0~10V/0~20mA) depend on the configuration of J16.

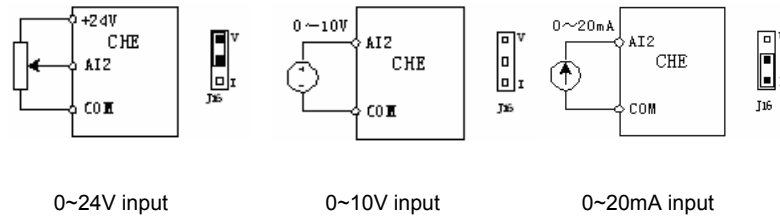

Figure 4.17 Wiring of size A (0.4~0.75kW 1AC).

To the external potentiometer, resistance should be greater than 3k Ω and power should be greater than 1/4W. Its resistance is recommended to be 5~10k Ω .

Notice:

The terminal will use the internal circuit to adjust the input signal. To the first two work mode, the relative internal voltage range is 0~10V. And to the third work mode, the relative internal voltage range is 0~5V.

4.7 Installation Guideline to EMC Compliance

4.7.1 General description of EMC

EMC is the abbreviation of electromagnetic compatibility, which means the device or system has the ability to work normally in the electromagnetic environment and will not generate any electromagnetic interference to other equipments.

EMC includes two subjects: electromagnetic interference and electromagnetic anti-jamming.

According to the transmission mode, Electromagnetic interference can be divided into two categories: conducted interference and radiated interference.

Conducted interference is the interference transmitted by conductor. Therefore, any conductors (such as wire, transmission line, inductor, capacitor and so on) are the transmission channels of the interference.

Radiated interference is the interference transmitted in electromagnetic wave, and the energy is inverse proportional to the square of distance.

Three necessary conditions or essentials of electromagnetic interference are: interference source, transmission channel and sensitive receiver. For customers, the solution of EMC problem is mainly in transmission channel because of the device attribute of disturbance source and receiver can not be changed

4.7.2 EMC features of inverter

Like other electric or electronic devices, inverter is not only an electromagnetic interference source but also an electromagnetic receiver. The operating principle of inverter determines that it can produce certain electromagnetic interference noise. And the same time inverter should be designed with certain anti-jamming ability to ensure the smooth working in certain electromagnetic environment. The following is its EMC features:

1. Input current is non-sine wave. The input current includes large amount of high-harmonic waves that can cause electromagnetic interference, decrease the grid power factor and increase the line loss.
2. Output voltage is high frequency PMW wave, which can increase the temperature rise and shorten the life of motor. And the leakage current will also increase, which can lead to the leakage protection device malfunction and generate strong electromagnetic interference to influence the reliability of other electric devices.

3. As the electromagnetic receiver, too strong interference will damage the inverter and influence the normal using of customers.

4. In the system, EMS and EMI of inverter coexist. Decrease the EMI of inverter can increase its EMS ability.

4.7.3 EMC Installation Guideline

In order to ensure all electric devices in the same system to work smoothly, this section, based on EMC features of inverter, introduces EMC installation process in several aspects of application (noise control, site wiring, grounding, leakage current and power supply filter). The good effective of EMC will depend on the good effective of all of these five aspects.

1. Noise control

All the connections to the control terminals must use shielded wire. And the shield layer of the wire must ground near the wire entrance of inverter. The ground mode is 360 degree annular connection formed by cable clips. It is strictly prohibitive to connect the twisted shielding layer to the ground of inverter, which greatly decreases or loses the shielding effect.

Connect inverter and motor with the shielded wire or the separated cable tray. One side of shield layer of shielded wire or metal cover of separated cable tray should connect to ground, and the other side should connect to the motor cover. Installing an EMC filter can reduce the electromagnetic noise greatly.

2. Site wiring

Power supply wiring: the power should be separated supplied from electrical transformer. Normally it is 5 core wires, three of which are fire wires, one of which is the neutral wire, and one of which is the ground wire. It is strictly prohibitive to use the same line to be both the neutral wire and the ground wire

Device categorization: there are different electric devices contained in one control cabinet, such as inverter, filter, PLC and instrument etc, which have different ability of emitting and withstanding electromagnetic noise. Therefore, it needs to categorize these devices into strong noise device and noise sensitive device. The same kinds of device should be placed in the same area, and the distance between devices of different category should be more than 20cm.

Wire Arrangement inside the control cabinet: there are signal wire (light current) and

power cable (strong current) in one cabinet. For the inverter, the power cables are categorized into input cable and output cable. Signal wires can be easily disturbed by power cables to make the equipment malfunction. Therefore when wiring, signal cables and power cables should be arranged in different area. It is strictly prohibitive to arrange them in parallel or interlacement at a close distance (less than 20cm) or tie them together. If the signal wires have to cross the power cables, they should be arranged in 90 angles. Power input and output cables should not either be arranged in interlacement or tied together, especially when installed the EMC filter. Otherwise the distributed capacitances of its input and output power cable can be coupling each other to make the EMC filter out of function.

3. Ground

Inverter must be ground safely when in operation. Grounding enjoys priority in all EMC methods because it does not only ensure the safety of equipment and persons, but also is the simplest, most effective and lowest cost solution for EMC problems.

Grounding has three categories: special pole grounding, common pole grounding and series-wound grounding. Different control system should use special pole grounding, and different devices in the same control system should use common pole grounding, and different devices connected by same power cable should use series-wound grounding.

4. Leakage Current

Leakage current includes line-to-line leakage current and over-ground leakage current. Its value depends on distributed capacitances and carrier frequency of inverter. The over-ground leakage current, which is the current passing through the common ground wire, can not only flow into inverter system but also other devices. It also can make leakage current circuit breaker, relay or other devices malfunction. The value of line-to-line leakage current, which means the leakage current passing through distributed capacitors of input output wire, depends on the carrier frequency of inverter, the length and section areas of motor cables. The higher carrier frequency of inverter, the longer of the motor cable and/or the bigger cable section area, the larger leakage current will occur.

Countermeasure:

Decreasing the carrier frequency can effectively decrease the leakage current. In the case of motor cable is relatively long (longer than 50m), it is necessary to install AC reactor or sinusoidal wave filter at the output side, and when it is even longer, it is

necessary to install one reactor at every certain distance.

5. EMC Filter

EMC filter has a great effect of electromagnetic decoupling, so it is preferred for customer to install it.

For inverter, noise filter has following categories:

- 1) Noise filter installed at the input side of inverter;
- 2) Install noise isolation for other equipment by means of isolation transformer or power filter.

5. OPERATION

5.1 Keypad Description

5.1.1 Keypad schematic diagram

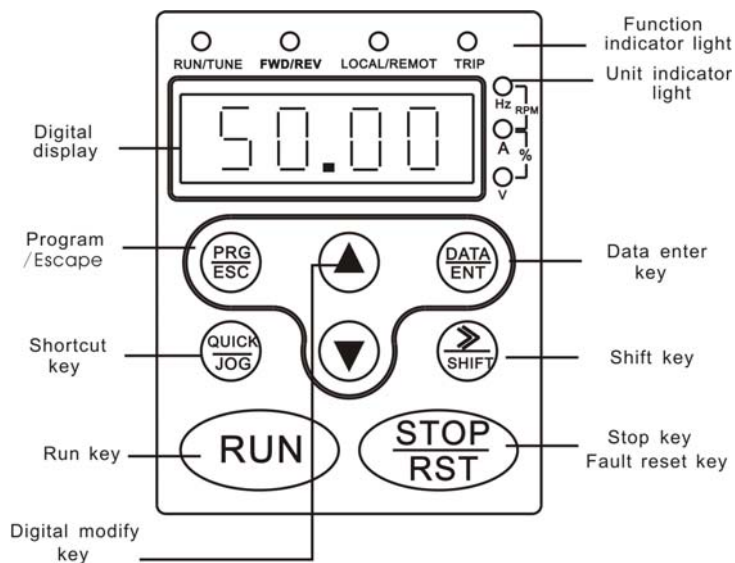









Figure 5.1 Keypad schematic diagram.

5.1.2 Key function description

| Button Symbol | Name | Function Description |
|---------------|--------------------|--|
| | Programming Key | Entry or escape of first-level menu. |
| | Enter Key | Progressively enter menu and confirm parameters. |
| | UP Increment Key | Progressively increase data or function codes. |
| | DOWN Decrement Key | Progressive decrease data or function codes. |

| | | |
|---|----------------------------|--|
|  +  | Combination Key | Cyclically displays parameters by left shift, In the stop or running status. Note that when operation, should firstly press and hold the DATA/ENT key and then press the QUICK/JOG key. |
|  | Shift Key | In parameter setting mode, press this button to select the bit to be modified. In other modes, cyclically displays parameters by right shift |
|  | Run Key | Start to run the inverter in keypad control mode. |
|  | STOP/RESET Key | In running status, restricted by P7.04, can be used to stop the inverter. When fault alarm, can be used to reset the inverter without any restriction. |
|  | Shortcut Multifunction Key | Determined by Function Code P7.03: 0: Jog operation 1: Switch between forward and reverse 2: Clear the UP/DOWN settings. 3: Quick debugging mode1 (by menu) 4: Quick debugging mode2 (by latest order) 5: Quick debugging mode3 (by non-factory setting parameters) |
|  +  | Combination Key | Pressing the RUN and STOP/REST at the same time can achieve inverter coast to stop. |

5.1.3 Indicator light description

1) Function Indicator Light Description

| Indicator Light Name | Indicator Light Description |
|----------------------|--|
| RUN/TUNE | Extinguished: stop status Flickering: parameter autotuning status Light on: operating status |
| FWD/REV | Extinguished: forward operation Light on: reverse operation. |
| LOCAL/REMOT | Extinguished: keypad control Flickering: terminal control Light on: communication control |
| TRIP | Extinguished: normal operation status Flickering: overload pre-warning status |

2) Unit Indicator Light Description

| Symbol | Description |
|--------|---------------------|
| Hz | Frequency unit |
| A | Current unit |
| V | Voltage unit |
| RPM | Rotation speed unit |
| % | Percentage |

3) Digital Display

Have 5 digit LED , which can display all kinds of monitoring data and alarm codes such as reference frequency, output frequency and so on.

5.2 Operation Process

5.2.1 Parameter setting

Three levels of menu are:

1. Function code group (first-level);
2. Function code (second-level);
3. Function code value (third-level).

Remarks:

Press both the **PRG/ESC** and the **DATA/ENT** can return to the second-class menu from the third-class menu. The difference is: pressing **PRG/ESC** will save the set parameters into the control panel, and then return to the second-class menu with shifting to the next function code automatically; while pressing **DATA/ENT** will directly return to the second-class menu without saving the parameters, and keep staying at the current function code

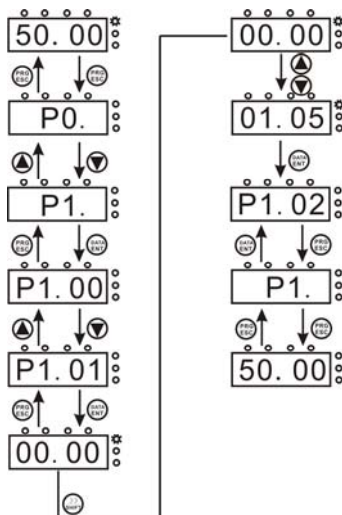

Figure 5.2 Flow chart of parameter setting.

Under the third-class menu, if the parameter has no flickering bit, it means the function code cannot be modified. The possible reasons could be:

- 1) This function code is not modifiable parameter, such as actual detected parameter, operation records and so on;
- 2) This function code is not modifiable in running status, but modifiable in stop status

5.2.2 Fault reset

If the inverter has fault, it will prompt the related fault information. User can use **STOP/RST** or according terminals determined by P5 Group to reset the fault. After fault reset, the inverter is at stand-by state. If user does not reset the inverter when it is at fault state, the inverter will be at operation protection state, and can not run.

5.2.3 Motor parameter autotuning

If "Sensorless Vector Control" mode is chosen, motor nameplate parameters must be input correctly as the autotuning is based on it. The performance of vector control depends on the parameters of motor strongly, so to achieve excellent performance, firstly must obtain the parameter of motor exactly.

The procedure of motor parameter autotuning is as follows:

Firstly, choose the keypad command channel as the operation command channel (P0.01).

And then input following parameters according to the actual motor parameters:

- P2.00: motor rated power.
- P2.01: motor rated frequency;
- P2.02: motor rated speed;
- P2.03: motor rated voltage;
- P2.04: motor rated current

Notice: the motor should be uncoupled with its load; otherwise, the motor parameters obtained by autotuning may be not correct. Set P0.12 to be 1, and for the detail process of motor parameter autotuning, please refer to the description of Function Code P0.12. And then press **RUN** on the keypad panel, the inverter will automatically calculate following parameter of the motor:

- P2.05: motor stator resistance;
 - P2.06: motor rotor resistance;
 - P2.07: motor stator and rotor inductance;
 - P2.08: motor stator and rotor mutual inductance;
 - P2.09: motor current without load;
- then motor autotuning is finished.

5.2.4 Password setting

CHE series inverter offers user's password protection function. When P7.00 is set to be nonzero, it will be the user's password, and After exiting function code edit mode, it will become effective after 1 minute. If pressing the **PRG/ESC** again to try to access the function code edit mode, "0.0.0.0.0" will be displayed, and the operator must input correct user's password, otherwise will be unable to access it.

If it is necessary to cancel the password protection function, just set P7.00 to be zero.

5.3 Running State

5.3.1 Power-on initialization

Firstly the system initializes during the inverter power-on, and LED displays "-CHE-". After the initialization is completed, the inverter is on stand-by status.

5.3.2 Stand-by

At stop or running status, parameters of multi-status can be displayed. Whether or not to display this parameter can be chosen through Function Code P7.06(Running status display selection) and P7.07 (Stop status display selection) according to binary bits, the detailed description of each bit please refer the function code description of P7.06 and P7.07.

In stop status, there are nine parameters which can be chosen to display or not. They are: reference frequency, DC bus voltage, ON-OFF input status, open collector output status, PID setting, PID feedback, analog input AI1 voltage, analog input AI2 voltage, step number of multi-step speed. Whether or not to display can be decided by setting the corresponding binary bit of P7.07. Press the **▶/SHIFT** to scroll through the parameters in right order . Press **DATA/ENT** + **QUICK/JOG** to scroll through the parameters in left order.

5.3.3 Motor parameter autotuning

For details, please refer to the description of P0.12.

5.3.4 Operation

In running status, there are fourteen running parameters: output frequency, reference frequency, DC bus voltage, output voltage, output current, output power, output torque, PID setting, PID feedback, ON-OFF input status, open collector output status, length value, count value, step number of PLC and multi-step speed, voltage of AI1, voltage of AI2 and step number of multi-step speed. Whether or not to display can be decided by the bit option of Function Code P7.06 (converted into binary system). Press the **▶/SHIFT** to scroll through the parameters in right order . Press **DATA/ENT** + **QUICK/JOG** to scroll through the parameters in left order.

5.3.5 Fault

CHE series inverter offers a variety of fault information. For details, see inverter faults and their troubleshooting.

5.4 Quick Testing

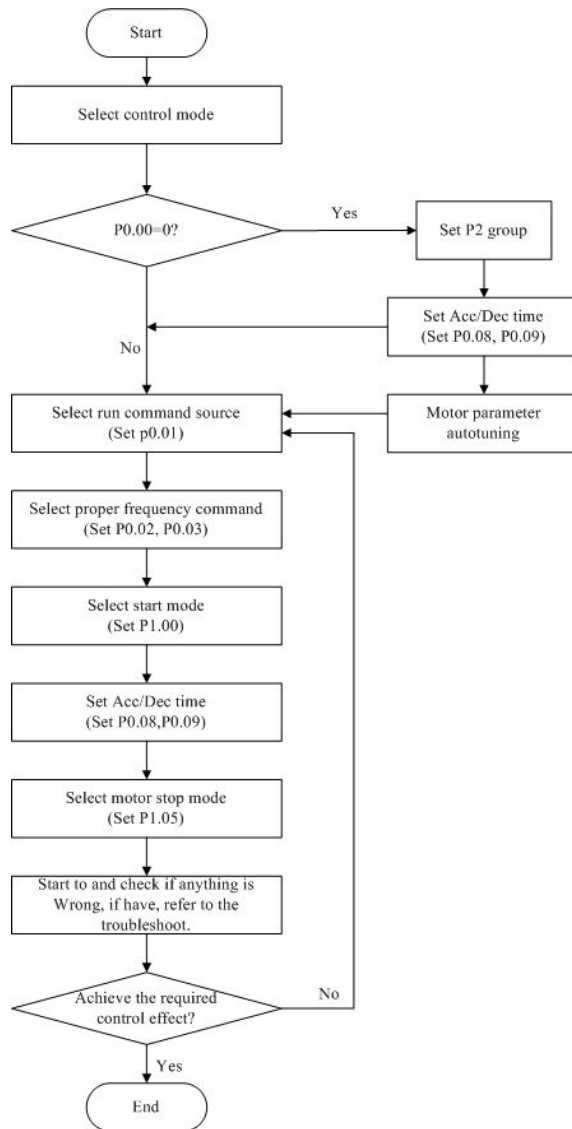

Figure 5.3 Quick testing.

6. DETAILED FUNCTION DESCRIPTION

6.1 P0 Group--Basic Function

| Function Code | Name | Description | Setting Range | Factory Setting |
|---------------|------------------------|--|---------------|-----------------|
| P0.00 | Control mode selection | 0:Sensorless vector control 1:V/F control 2:Torque control | 0~2 | 0 |

0: Sensorless vector control: It is widely used for the application which requires high torque at low speed, higher speed accuracy, and quicker dynamic response, such as machine tool, injection molding machine, centrifugal machine and wire-drawing machine, etc.

1: V/F control: It is suitable for general purpose application such as pumps, fans etc.

2: Torque control: It is suitable for the application with low accuracy torque control, such as wire-drawing. In torque control mode, the speed of motor is determined by load, the rate of ACC/DEC has nothing to do with the value of P0.08 and P0.09 (or P8.00 and P8.01).

Notice:

- Inverter can drive only one motor when P0.00 is set to be 0 or 2. When P0.00 is set to be 1, inverter can drive multi motors.**
- The autotuning of motor parameters must be accomplished properly when P0.00 is set to be 0 or 2.**
- In order to achieve better control characteristic, the parameters of speed regulator (P3.00~P3.05) must be adjusted according to actual situation when P0.00 is set to be 0 or 2.**

| Function Code | Name | Description | Setting Range | Factory Setting |
|---------------|--------------------|--|---------------|-----------------|
| P0.01 | Run command source | 0: Keypad (LED extinguished) 1: Terminal (LED flickering) 2: Communication (LED lights on) | 0~2 | 0 |

The control commands of inverter include: start, stop, forward run, reverse run, jog, fault reset and so on.

0: Keypad (LED extinguished);

Both **RUN** and **STOP/RST** key are used for running command control. If Multifunction key **QUICK/JOG** is set as FWD/REV switching function (P7.03 is set to be 1), it will be used to change the rotating orientation. **In running status, pressing **RUN** and **STOP/RST** in the same time will cause the inverter coast to stop.**

1: Terminal (LED flickering)

The operation, including forward run, reverse run, forward jog, reverse jog etc. can be controlled by multifunctional input terminals.

2: Communication (LED lights on)

The operation of inverter can be controlled by the host through communication.

| Function Code | Name | Description | Setting Range | Factory Setting |
|---------------|-----------------|--|---------------|-----------------|
| P0.02 | UP/DOWN setting | 0: Valid, save UP/DOWN value when power off 1: Valid, do not save UP/DOWN value when power off 2: Invalid 3: Valid during running, clear when stop. | 0~3 | 0 |

0: User can adjust the reference frequency by UP/DOWN. The value of UP/DOWN can be saved when power off.

1: User can adjust the reference frequency by UP/DOWN, but the value of UP/DOWN will not be saved when power off.

2: User can not adjust the reference frequency by UP/DOWN. The value of UP/DOWN will be cleared if P3.05 is set to 2.

3: User can only adjust the reference frequency by UP/DOWN during the inverter is running. The value of UP/DOWN will be cleared when the inverter stops.

Notice:

1. UP/DOWN function can be achieved by keypad () and () and multifunctional terminals.
2. Reference frequency can be adjusted by UP/DOWN.
3. UP/DOWN has highest priority which means UP/DOWN is always active no matter which frequency command source is.
4. When the factory setting is restored (P1.03 is set to be 1), the value of UP/DOWN will be cleared

| Function Code | Name | Description | Setting Range | Factory Setting |
|---------------|----------------------------|--|---------------|-----------------|
| P0.03 | Frequency A command source | 0: Keypad 1: AI1 2: AI2 3: AI1+AI2 4: Multi-Step speed 5: PID 6: Communication | 0~6 | 0 |

Detailed Function Description

0: Keypad: Please refer to description of P3.00

1: AI1

2: AI2

3:AI1+AI2

The reference frequency is set by analog input. CHE series inverter provides 2 analog input terminals. AI1 is 0~10V voltage input terminal, while AI2 is 0~10V voltage input or 0~20mA current input. Voltage input or current input of AI2 can be selected by Jumper J16.

Notice:

- **When AI2 is set as 0~20mA current input, the corresponding voltage range is 0~5V. For detailed relationship between analogue input voltage and frequency, please refer to description of P5.07~P5.11.**
- **100% of AI is corresponding to maximum frequency(P0.04)**

4: Multi-step speed

The reference frequency is determined by PA group. The selection of steps is determined by combination of multi-step speed terminals.

Notice:

- **Multi-step speed mode will enjoy priority in setting reference frequency if P0.03 is not set to be 4. In this case, only step 1 to step 15 are available.**
- **If P0.03 is set to be 4, step 0 to step 15 can be realized.**

Jog has highest priority.

5: PID

The reference frequency is the result of PID adjustment. For details, please refer to description of P9 group

6: Communication

The reference frequency is set through RS485. For details, please refer to description of Chapter 10.

| Function Code | Name | Description | Setting Range | Factory Setting |
|---------------|-------------------|----------------|---------------|-----------------|
| P0.04 | Maximum frequency | P0.05~600.00Hz | P0.05~600.00 | 50.00Hz |

Notice:

1. **The frequency reference should not exceed maximum frequency.**
2. **Actual acceleration time and deceleration time are determined by maximum frequency. Please refer to description of P0.08 and P0.09.**

| Function Code | Name | Description | Setting Range | Factory Setting |
|---------------|-----------------------|--------------|---------------|-----------------|
| P0.05 | Upper frequency limit | P0.06~ P0.04 | P0.06~P0.04 | 50.00Hz |

Notice:

- Upper frequency limit should not be greater than the maximum frequency (P0.04).
- Output frequency should not exceed upper frequency limit.

| Function Code | Name | Description | Setting Range | Factory Setting |
|---------------|-----------------------|-----------------|---------------|-----------------|
| P0.06 | Lower frequency limit | 0.00 Hz ~ P0.05 | 0.00~P0.05 | 0.00Hz |

Notice:

- Lower frequency limit should not be greater than upper frequency limit (P0.05).
- If frequency reference is lower than P0.06, the action of inverter is determined by P1.12. Please refer to description of P1.12.

| Function Code | Name | Description | Setting Range | Factory Setting |
|---------------|----------------------------|-----------------|---------------|-----------------|
| P0.07 | Keypad reference frequency | 0.00 Hz ~ P0.04 | 0.00~P0.04 | 50.00Hz |

When P0.03 is set to be 0, this parameter is the initial value of inverter reference frequency

| Function Code | Name | Description | Setting Range | Factory Setting |
|---------------|---------------------|-------------|---------------|-----------------|
| P0.08 | Acceleration time 0 | 0.0~3600.0s | 0.0~3600.0 | Depend on model |
| P0.09 | Deceleration time 0 | 0.0~3600.0s | 0.0~3600.0 | Depend on model |

Acceleration time is the time of accelerating from 0Hz to maximum frequency (P0.04). Deceleration time is the time of decelerating from maximum frequency (P0.04) to 0Hz.

Please refer to following figure.

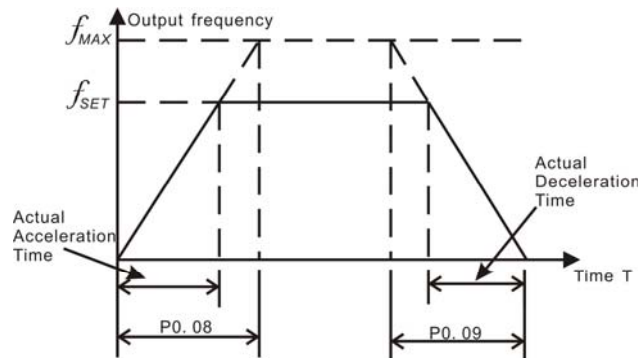

Figure 6.1 Acceleration and deceleration time.

Detailed Function Description

When the reference frequency is equal to the maximum frequency, the actual acceleration and deceleration time will be equal to the P0.08 and P0.09 respectively.

When the reference frequency is less than the maximum frequency, the actual acceleration and deceleration time will be less than the P0.08 and P0.09 respectively.

The actual acceleration (deceleration) time = P0.08 (P0.09) * reference frequency/P0.04.

CHE series inverter has 2 groups of acceleration and deceleration time.

1st group: P0.07, P0.08

2nd group: P8.00, P8.01

The acceleration and deceleration time can be selected by combination of multifunctional ON-OFF input terminals determined by P5 Group. The factory setting of acceleration and deceleration time is as follow:

- 5.5kW and below: 10.0s
- 7.5kW~30kW: 20.0s
- 37kW and above: 40.0s

| Function Code | Name | Description | Setting Range | Factory Setting |
|---------------|-----------------------------|---|---------------|-----------------|
| P0.10 | Running direction selection | 0: Forward 1: Reverse 2: Forbid reverse | 0~2 | 0 |

Notice:

1. The rotation direction of motor is corresponding to the wiring of motor.
2. When the factory setting is restored (P0.13 is set to be 1), the rotation direction of motor may be changed. Please be cautious to use.

If P0.10 is set to 2, user can not change rotation direction of motor by **QUICK/JOG** or terminal.

| Function Code | Name | Description | Setting Range | Factory Setting |
|---------------|-------------------|-------------|---------------|-----------------|
| P0.11 | Carrier frequency | 0.5~15.0kHz | 0.5~15.0 | Depend on model |

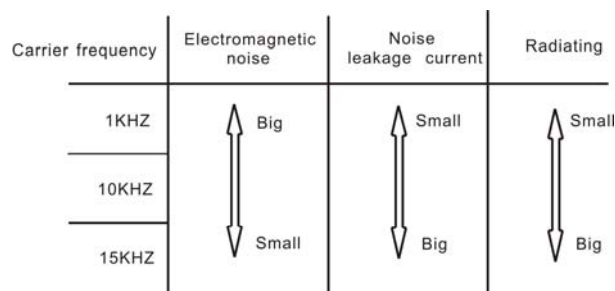

Figure 6.2 Effect of carrier frequency.

The following table is the relationship between power rating and carrier frequency.

| Carrier f Model | Highest Carrier f (kHz) | Lowest Carrier f (kHz) | Factory setting (kHz) |
|---|------------------------------|-----------------------------|----------------------------|
| G Model: 0.4kW~11kW P Model: 0.75kW~15kW | 15 | 1 | 8 |
| G Model: 15kW~55kW P Model: 18.5kW~75kW | 8 | 1 | 4 |
| G Model: 75kW~300kW P Model: 90kW~315kW | 6 | 1 | 2 |

Carrier frequency will affect the noise of motor and the EMI of inverter.

If the carrier frequency is increased, it will cause better current wave, less harmonic current and lower noise of motor.

Notice:

- 1. The factory setting is optimal in most cases. Modification of this parameter is not recommended.**
- 2. If the carrier frequency exceeds the factory setting, the inverter must be derated because the higher carrier frequency will cause more switching loss, higher temperature rise of inverter and stronger electromagnetic interference.**

If the carrier frequency is lower than the factory setting, it is possible to cause less output torque of motor and more harmonic current.

| Function Code | Name | Description | Setting Range | Factory Setting |
|---------------|-----------------------------|--|---------------|-----------------|
| P0.12 | Motor parameters autotuning | 0: No action 1: Rotation autotuning 2: Static autotuning | 0~2 | 0 |

0: No action: Forbidding autotuning.

1: Rotation autotuning:

- Do not connect any load to the motor when performing autotuning and ensure the motor is in static status.
- Input the nameplate parameters of motor (P2.01~P2.05) correctly before performing autotuning. Otherwise the parameters detected by autotuning will be incorrect; it may influence the performance of inverter.
- Set the proper acceleration and deceleration time (P0.08 and P0.09) according to the motor inertia before performing autotuning. Otherwise it may cause over-current and over-voltage fault during autotuning.

Detailed Function Description

- The operation process is as follow:
 - a. Set P0.12 to be 1 then press the **DATA/ENT**, LED will display “-TUN-” and flickers. During “-TUN-” is flickering, press the **PRG/ESC** to exit autotuning.
 - b. Press the **RUN** to start the autotuning. LED will display “TUN-0”.
 - c. After a few seconds the motor will start to run. LED will display “TUN-1” and “RUN/TUNE” light will flicker.
 - d. After a few minutes, LED will display “-END-”. That means the autotuning is finished and return to the stop status.
 - e. During the autotuning, press the **STOP/RST** will stop the autotuning.

Notice: Only keypad can control the autotuning. P0.12 will restore to 0 automatically when the autotuning is finished or cancelled.

2: Static autotuning:

- If it is difficult to disconnect the load, static autotuning is recommended.
- The operation process is the same as rotation autotuning except step c.

Notice: The Mutual inductance and current without load will not be detected by static autotuning, if needed user should input suitable value according to experience.

| Function Code | Name | Description | Setting Range | Factory Setting |
|---------------|--------------------|--|---------------|-----------------|
| P0.13 | Restore parameters | 0: No action 1: Restore factory setting 2: Clear fault records | 0~2 | 0 |

0: No action

1: Inverter restores all parameters to factory setting except P2 group.

2: Inverter clear all fault records.

This function code will restore to 0 automatically when complete the function operation.

| Function Code | Name | Description | Setting Range | Factory Setting |
|---------------|--------------|---|---------------|-----------------|
| P0.14 | AVR function | 0: Disabled 1: Enabled all the time 2: Disabled during deceleration | 0~2 | 1 |

AVR (Auto Voltage Regulation) function ensure the output voltage of inverter stable no matter how the DC bus voltage changes. During deceleration, if AVR function is disabled, the deceleration time will be short but the current will be big. If AVR function is enabled all the time, the deceleration time will be long but the current will be small.

6.2 P1 Group--Start and Stop Control

| Function Code | Name | Description | Setting Range | Factory Setting |
|---------------|------------|--|---------------|-----------------|
| P1.00 | Start Mode | 0: Start directly 1: DC braking and start | 0~1 | 0 |

0: Start directly: Start the motor at the starting frequency determined by P1.01.

1: DC braking and start: Inverter will output DC current firstly and then start the motor at the starting frequency. Please refer to description of P1.03 and P1.04. It is suitable for the motor which have small inertia load and may reverse rotation when start.

| Function Code | Name | Description | Setting Range | Factory Setting |
|---------------|---------------------------------|--------------|---------------|-----------------|
| P1.01 | Starting frequency | 0.00~10.00Hz | 0.00~10.00 | 0.00Hz |
| P1.02 | Hold time of starting frequency | 0.0~50.0s | 0.0~50.0 | 0.0s |

- Set proper starting frequency can increase the starting torque.
- If the reference frequency is less than starting frequency, inverter will be at stand-by status. The indicator of **RUN/TUNE** lights on, inverter has no output.
- The starting frequency could be less than the lower frequency limit (P0.06).
- P1.01 and P1.02 take no effect during FWD/REV switching.

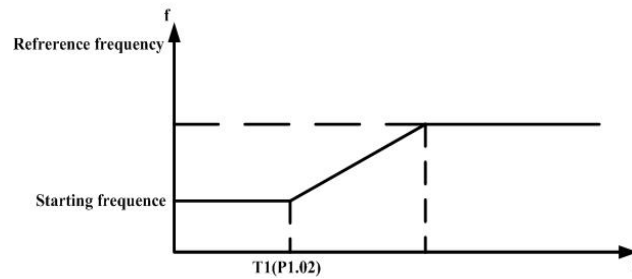

Figure 6.3 Starting diagram.

| Function Code | Name | Description | Setting Range | Factory Setting |
|---------------|---------------------------------|-------------|---------------|-----------------|
| P1.03 | DC Braking current before start | 0.0~150.0% | 0.0~150.0 | 0.0% |
| P1.04 | DC Braking time before start | 0.0~50.0s | 0.0~50.0 | 0.0s |

When inverter starts, it performs DC braking according to P1.03 firstly, then start to accelerate after P1.04.

Notice:

1. DC braking will take effect only when P1.00 is set to be 1.
2. DC braking is invalid when P1.04 is set to be 0.

Detailed Function Description

The value of P1.03 is the percentage of rated current of inverter. The bigger the DC braking current, the greater the braking torque.

| Function Code | Name | Description | Setting Range | Factory Setting |
|---------------|-----------|---|---------------|-----------------|
| P1.05 | Stop mode | 0: Deceleration to stop 1: Coast to stop | 0~1 | 0 |

0: Deceleration to stop

When the stop command takes effect, the inverter decreases the output frequency according to the selected acceleration/deceleration time till stop.

1: Coast to stop

When the stop command takes effect, the inverter blocks the output immediately. The motor coasts to stop by its mechanical inertia.

| Function Code | Name | Description | Setting Range | Factory Setting |
|---------------|----------------------------------|-------------|---------------|-----------------|
| P1.06 | Starting frequency of DC braking | 0.00~P0.04 | 0.00~50.00 | 0.00Hz |
| P1.07 | Waiting time before DC braking | 0.0~50.0s | 0.0~50.0 | 0.0s |
| P1.08 | DC braking current | 0.0~150.0% | 0.0~150.0 | 0.0% |
| P1.09 | DC braking time | 0.0~50.0s | 0.0~50.0 | 0.0s |

Starting frequency of DC braking: Start the DC braking when output frequency reaches starting frequency determined by P1.06.

Waiting time before DC braking: Inverter blocks the output before starting the DC braking. After this waiting time, the DC braking will be started. It is used to prevent over-current fault caused by DC braking at high speed.

DC braking current: The value of P1.08 is the percentage of rated current of inverter. The bigger the DC braking current, the greater the braking torque.

DC braking time: The time used to perform DC braking. If the time is 0, the DC braking will be invalid.

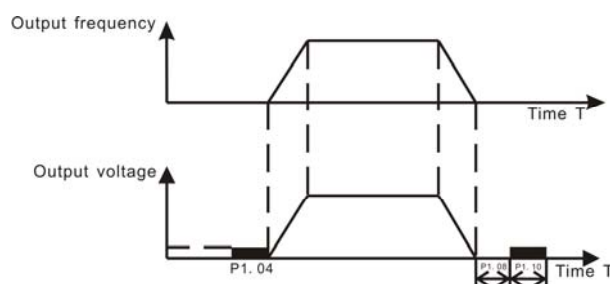

Figure 6.4 DC braking diagram.

| Function Code | Name | Description | Setting Range | Factory Setting |
|---------------|----------------------|-------------|---------------|-----------------|
| P1.10 | Dead time of FWD/REV | 0.0~3600.0s | 0.0~3600.0 | 0.0s |

Set the hold time at zero frequency in the transition between forward and reverse running.

It is shown as following figure:

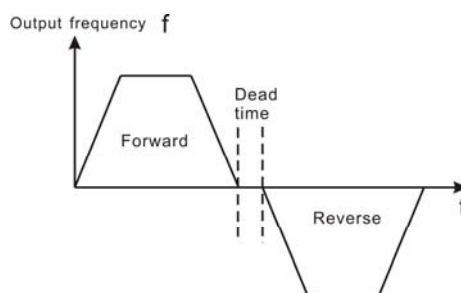

Figure 6.5 FWD/REV dead time diagram.

| Function Code | Name | Description | Setting Range | Factory Setting |
|---------------|-------------------------------------|---------------------------|---------------|-----------------|
| P1.11 | FWD/REV enable option when power on | 0: Disabled 1: Enabled | 0~1 | 0 |

Notice:

1. This function only takes effect if run command source is terminal control.
2. If P1.11 is set to be 0, when power on, inverter will not start even if FWD/REV terminal is active, until FWD/REV terminal disabled and enabled again.
3. If P1.11 is set to be 1, when power on and FWD/REV terminal is active, inverter will start automatically.
4. This function may cause the inverter restart automatically, please be cautious.

6.3 P2 Group--Motor Parameters

| Function Code | Name | Description | Setting Range | Factory Setting |
|---------------|------------|--------------------------|---------------|-----------------|
| P2.00 | G/P option | 0: G model 1: P model | 0~1 | 0 |

0: Applicable to constant torque load

1: Applicable to variable torque load (i.e. fans, pumps)

Detailed Function Description

CHE series inverters provide the G/P integration function. The adaptive motor power used for constant torque load (G model) should be one grade less than that used for variable torque load (P model).

To change from G model to P model, procedures are as follow:

①Set P2.00 to be 1;

②Input motor parameters in P2 group again..

| Function Code | Name | Description | Setting Range | Factory Setting |
|---------------|-----------------------|--------------|---------------|-----------------|
| P2.01 | Motor rated power | 0.4~900.0kW | 0.4~900.0 | Depend on model |
| P2.02 | Motor rated frequency | 0.01Hz~P0.04 | 0.01~P0.04 | 50.00Hz |
| P2.03 | Motor rated speed | 0~36000rpm | 0~36000 | Depend on model |
| P2.04 | Motor rated voltage | 0~2000V | 0~2000V | Depend on model |
| P2.05 | Motor rated current | 0.8~2000.0A | 0.8~2000.0 | Depend on model |

Notice:

- In order to achieve superior performance, please set these parameters according to motor nameplate, then perform autotuning.**
- The power rating of inverter should match the motor. If the bias is too big, the control performances of inverter will be deteriorated distinctly. Reset P2.01 can initialize P2.02~P2.10 automatically.**

| Function Code | Name | Description | Setting Range | Factory Setting |
|---------------|--------------------------|---------------|---------------|-----------------|
| P2.06 | Motor stator resistance | 0.001~65.535Ω | 0.001~65.535 | Depend on model |
| P2.07 | Motor rotor resistance | 0.001~65.535Ω | 0.001~65.535 | Depend on model |
| P2.08 | Motor leakage inductance | 0.1~6553.5mH | 0.1~6553.5 | Depend on model |
| P2.09 | Motor mutual inductance | 0.1~6553.5mH | 0.1~6553.5 | Depend on model |
| P2.10 | Current without load | 0.01~655.35A | 0.01~655.35 | Depend on model |

After autotuning, the value of P2.06~P2.10 will be automatically updated.

Notice: Do not change these parameters, otherwise it may deteriorate the control performance of inverter.

6.4 P3 Group—Vector Control

| Function Code | Name | Description | Setting Range | Factory Setting |
|---------------|------------------------------|--------------|---------------|-----------------|
| P3.00 | ASR proportional gain K_p1 | 0~100 | 0~100 | 20 |
| P3.01 | ASR integral time K_i1 | 0.01~10.00s | 0.01~10.00 | 0.50s |
| P3.02 | ASR switching point 1 | 0.00Hz~P3.05 | 0.00~P3.05 | 5.00Hz |
| P3.03 | ASR proportional gain K_p2 | 0~100 | 0~100 | 25 |
| P3.04 | ASR integral time K_i2 | 0.01~10.00s | 0.01~10.00 | 1.00s |
| P3.05 | ASR switching point 2 | P3.02~P0.04 | P3.02~P0.04 | 10.00Hz |

P3.00~P3.05 are only valid for vector control and torque control and invalid for V/F control. Through P3.00~P3.05, user can set the proportional gain K_p and integral time K_i of speed regulator (ASR), so as to change the speed response characteristic. ASR's structure is shown in following figure.

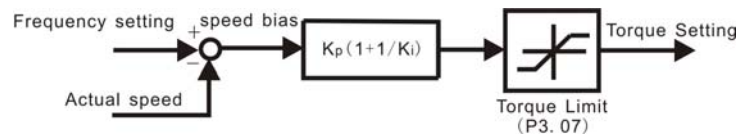

Figure 6.6 ASR diagram.

P3.00 and P3.01 only take effect when output frequency is less than P3.02. P3.03 and P3.04 only take effect when output frequency is greater than P3.05. When output frequency is between P3.02 and P3.05, K_p and K_i are proportional to the bias between P3.02 and P3.05. For details, please refer to following figure.

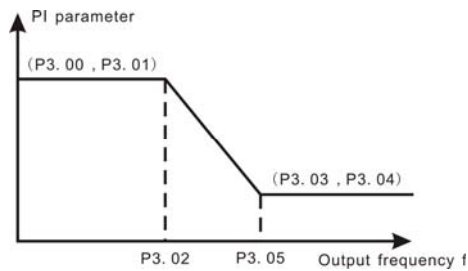

Figure 6.7 PI parameter diagram.

Detailed Function Description

The system's dynamic response can be faster if the proportion gain K_p is increased; However, if K_p is too large, the system tends to oscillate.

The system dynamic response can be faster if the integral time K_i is decreased;

However, if K_i is too small, the system becomes overshoot and tends to oscillate.

P3.00 and P3.01 are corresponding to K_p and K_i at low frequency, while P3.03 and P3.04 are corresponding to K_p and K_i at high frequency. Please adjust these parameters according to actual situation. The adjustment procedure is as follow:

1. Increase the proportional gain (K_p) as far as possible without creating oscillation.
2. Reduce the integral time (K_i) as far as possible without creating oscillation.

For more details about fine adjustment, please refer to description of P9 group.

| Function Code | Name | Description | Setting Range | Factory Setting |
|---------------|------------------------------|-------------|---------------|-----------------|
| P3.06 | Slip compensation rate of VC | 50.0~200.0% | 50.0~200.0 | 100% |

The parameter is used to adjust the slip frequency of vector control and improve the precision of speed control. Properly adjusting this parameter can effectively restrain the static speed bias.

| Function Code | Name | Description | Setting Range | Factory Setting |
|---------------|--------------|-------------|---------------|-----------------|
| P3.07 | Torque limit | 0.0~200.0% | 0.0~200.0 | 150.0% |

This parameter is used to limit the torque current output by speed regulator. Torque limit value 0.0-200% is the inverter's rated current percentage.

6.5 P4 Group-- V/F Control

| Function Code | Name | Description | Setting Range | Factory Setting |
|---------------|---------------------|---|---------------|-----------------|
| P4.00 | V/F curve selection | 0: Linear curve 1: Torque_stepdown curve (2.0 order) | 0~1 | 0 |

0: Linear curve. It is applicable for normal constant torque load.

1: Torque_stepdown curve. It is applicable for variable torque load, such as blower, pump and so on. Please refer to following figure.

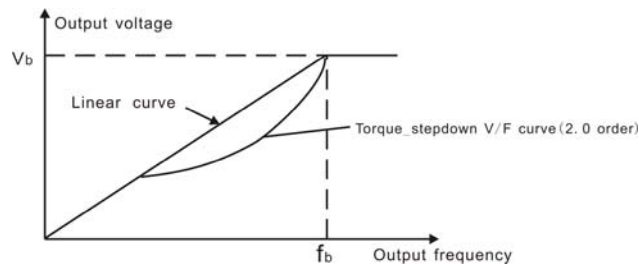

Figure6.8 V/F curve diagram.

| Function Code | Name | Description | Setting Range | Factory Setting |
|---------------|----------------------|------------------------------------|---------------|-----------------|
| P4.01 | Torque boost | 0.0%: (auto) 0.1%~10.0% | 0.0~10.0 | 0.0% |
| P4.02 | Torque boost cut-off | 0.0%~50.0% (motor rated frequency) | 0.0~50.0 | 20.0% |

Torque boost will take effect when output frequency is less than cut-off frequency of torque boost (P4.02). Torque boost can improve the torque performance of V/F control at low speed.

The value of torque boost should be determined by the load. The heavier the load, the larger the value.

Notice: P4.01 should not be too large, otherwise the motor would be over-heat or the inverter would be tripped by over-current or over-load.

If P4.01 is set to be 0, the inverter will boost the output torque according to the load automatically.

Please refer to following diagram.

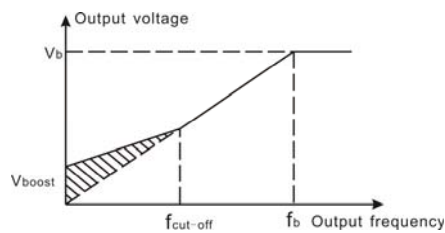

Figure 6.9 Manual torque boost diagram.

| Function Code | Name | Description | Setting Range | Factory Setting |
|---------------|-----------------------------|-------------|---------------|-----------------|
| P4.03 | V/F Slip compensation limit | 0.00~200.0% | 0.00~200.00 | 0.0% |

The slip compensation function calculates the torque of motor according to the output current and compensates for output frequency. This function is used to improve speed accuracy when operating with a load. P4.03 sets the slip compensation limit as a percentage of motor rated slip, with the motor rated slip taken as 100%.

| Function Code | Name | Description | Setting Range | Factory Setting |
|---------------|------------------------------|---------------------------|---------------|-----------------|
| P4.04 | Auto energy saving selection | 0: Disabled 1: Enabled | 0~1 | 0 |

When P4.04 is set to be 1, while there is a light load, it will reduce the inverter output voltage and saves energy.

6.6 P5 Group--Input Terminals

| Function Code | Name | Description | Setting Range | Factory Setting |
|---------------|----------------------|---------------------------------------|---------------|-----------------|
| P5.00 | S1 Terminal function | Programmable multifunctional terminal | 0~25 | 1 |
| P5.01 | S2 Terminal function | Programmable multifunctional terminal | 0~25 | 4 |
| P5.02 | S3 Terminal function | Programmable multifunctional terminal | 0~25 | 7 |
| P5.03 | S4 Terminal function | Programmable multifunctional terminal | 0~25 | 0 |

The meaning of each setting is shown in following table.

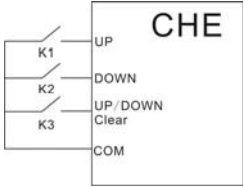
| Setting value | Function | Description |
|---------------|----------------------|--|
| 0 | Invalid | Please set unused terminals to be invalid to avoid malfunction. |
| 1 | Forward | Please refer to description of P5.05. |
| 2 | Reverse | |
| 3 | 3-wire control | Please refer to description of P5.05. |
| 4 | Jog forward | Please refer to description of P8.02~P8.04. |
| 5 | Jog reverse | |
| 6 | Coast to stop | The inverter blocks the output immediately. The motor coasts to stop by its mechanical inertia. |
| 7 | Reset fault | Resets faults that have occurred. It has the same function as STOP/RST . |
| 8 | External fault input | Stop the inverter and output a alarm when a fault occurs in a peripheral device. |
| 9 | Up command | <p>The reference frequency of inverter can be adjusted by UP command and DOWN command.</p>  <p>The diagram shows a terminal block labeled 'CHE' with four terminals: UP, DOWN, UP/DOWN Clear, and COM. Three switches, K1, K2, and K3, are connected to the terminals. K1 is connected to the UP terminal, K2 to the DOWN terminal, and K3 to the UP/DOWN Clear terminal. The COM terminal is connected to the common terminal of all three switches.</p> |
| 10 | DOWN command | |
| 11 | Clear UP/DOWN | |

| 12 | Multi-step speed reference1 | 8 steps speed control can be realized by the combination of these four terminals. For details, please refer to: Multi-step speed reference terminal status and according step value table: | | | | | | | | | |
|----------|------------------------------|---|----------|--------------|-------------------------|-----|---------------------|-------------|----|---------------------|-------------|
| 13 | Multi-step speed reference 2 | | | | | | | | | | |
| 14 | Multi-step speed reference 3 | | | | | | | | | | |
| 15 | ACC/DEC time selection | <p>2 groups of ACC/DEC time can be selected by the combination of these two terminals.</p> <table border="1"> <thead> <tr> <th>Terminal</th> <th>ACC/DEC time</th> <th>Corresponding Parameter</th> </tr> </thead> <tbody> <tr> <td>OFF</td> <td>Acceleration Time 0</td> <td>P0.08、P0.09</td> </tr> <tr> <td>ON</td> <td>Acceleration Time 1</td> <td>P8.00、P8.01</td> </tr> </tbody> </table> | Terminal | ACC/DEC time | Corresponding Parameter | OFF | Acceleration Time 0 | P0.08、P0.09 | ON | Acceleration Time 1 | P8.00、P8.01 |
| Terminal | ACC/DEC time | Corresponding Parameter | | | | | | | | | |
| OFF | Acceleration Time 0 | P0.08、P0.09 | | | | | | | | | |
| ON | Acceleration Time 1 | P8.00、P8.01 | | | | | | | | | |
| 16 | Pause PID | PID adjustment will be paused and inverter keeps output frequency unchanged. | | | | | | | | | |
| 17 | Pause traverse operation | Inverter keeps output frequency unchanged. If this terminal is disabled, inverter will continue traverse operation from current frequency. | | | | | | | | | |
| 18 | Reset traverse operation | Reference frequency of inverter will be forced as center frequency of traverse operation. | | | | | | | | | |
| 19 | ACC/DEC ramp hold | Pauses acceleration or deceleration and maintains output frequency. When this terminal is disabled, acceleration/deceleration is restarted. | | | | | | | | | |
| 20 | Disable torque control | Torque control is disabled. Inverter will work in speed control mode. | | | | | | | | | |
| 21 | UP/DOWN invalid temporarily | UP/DOWN setting is invalid and will not be cleared. When this terminal is disabled, UP/DOWN setting before will be valid again. | | | | | | | | | |
| 22~25 | Reserved | Reserved | | | | | | | | | |

Detailed Function Description

Multi-step speed reference terminal status and according step value table:

| Terminal Step | Multi-step speed reference1 | Multi-step speed reference2 | Multi-step speed reference3 |
|---------------|-----------------------------|-----------------------------|-----------------------------|
| 0 | OFF | OFF | OFF |
| 1 | ON | OFF | OFF |
| 2 | OFF | ON | OFF |
| 3 | ON | ON | OFF |
| 4 | OFF | OFF | ON |
| 5 | ON | OFF | ON |
| 6 | OFF | ON | ON |
| 7 | ON | ON | ON |

| Function Code | Name | Description | Setting Range | Factory Setting |
|---------------|---------------------|-------------|---------------|-----------------|
| P5.04 | ON/OFF filter times | 1~10 | 1~10 | 5 |

This parameter is used to set filter strength of terminals (S1~S4). When interference is heavy, user should increase this value to prevent malfunction.

| Function Code | Name | Description | Setting Range | Factory Setting |
|---------------|----------------------|--|---------------|-----------------|
| P5.05 | FWD/REV control mode | 0: 2-wire control mode 1 1: 2-wire control mode 2 2: 3-wire control mode 1 3: 3-wire control mode 2 | 0~3 | 0 |

This parameter defines four different control modes that control the inverter operation through external terminals.

0: 2-wire control mode 1: Integrate START/STOP command with run direction.

| K1 | K2 | Run command |
|-----|-----|-------------|
| OFF | OFF | Stop |
| ON | OFF | FWD |
| OFF | ON | REV |
| ON | ON | Stop |

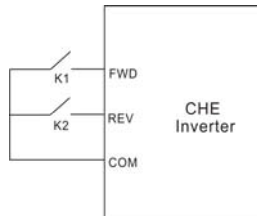

Figure 6.10 2-wire control mode1.

1: 2-wire control mode 2: START/STOP command is determined by FWD terminal. Run direction is determined by REV terminal.

| K1 | K2 | Run command |
|-----|-----|-------------|
| OFF | OFF | Stop |
| ON | OFF | FWD |
| OFF | ON | Stop |
| ON | ON | REV |

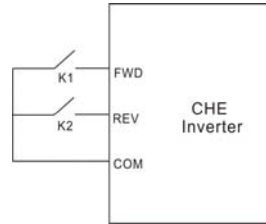

Figure 6.11 2-wire control mode 2.

2: 3-wire control mode 1:

SB1: Start button

SB2: Stop button (NC)

K: Run direction button

Terminal SIn is the multifunctional input terminal of S1~S4. The terminal function should be set to be 3 (3-wire control).

| K | Run command |
|-----|-------------|
| OFF | Stop |
| ON | FWD |

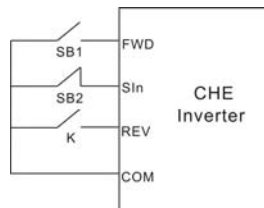

Figure 6.12 3-wire control mode 1.

3: 3-wire control mode 2:

SB1: Forward run button

SB2: Stop button (NC)

SB3: Reverse run button

Terminal SIn is the multifunctional input terminal of S1~S4. The terminal function should be set to be 3 (3-wire control)

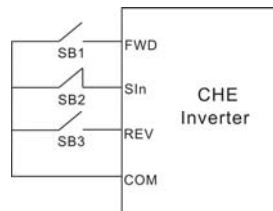

Figure 6.13 3-wire control mode2.

Notice: When 2-wire control mode is active, the inverter will not run in following situation even if FWD/REV terminal is enabled:

- Coast to stop (press **RUN** and **STOP/RST** at the same time).
- Stop command from serial communication.

FWD/REV terminal is enabled before power on. Please refer to description of P1.11.

| Function Code | Name | Description | Setting Range | Factory Setting |
|---------------|-----------------------------|----------------|---------------|-----------------|
| P5.06 | UP/DOWN setting change rate | 0.01~50.00Hz/s | 0.01~50.00 | 0.50Hz/s |

Terminal UP/DOWN regulates the incremental rate of setting frequency.

| Function Code | Name | Description | Setting Range | Factory Setting |
|---------------|---------------------------------------|----------------|---------------|-----------------|
| P5.07 | AI1 lower limit | 0.00V~10.00V | 0.00~10.00 | 0.00V |
| P5.08 | AI1 lower limit corresponding setting | -100.0%~100.0% | -100.0~100.0 | 0.0% |
| P5.09 | AI1 upper limit | 0.00V~10.00V | 0.00~10.00 | 10.00V |
| P5.10 | AI1 upper limit corresponding setting | -100.0%~100.0% | -100.0~100.0 | 100.0% |
| P5.11 | AI1 filter time constant | 0.00s~10.00s | 0.00~10.00 | 0.10s |

These parameters determine the relationship between analog input voltage and the corresponding setting value. When the analog input voltage exceeds the range between lower limit and upper limit, it will be regarded as the upper limit or lower limit.

The analog input AI1 can only provide voltage input, and the range is 0V~10V.

For different applications, the corresponding value of 100.0% analog setting is different.

For details, please refer to description of each application.

Notice: AI1 lower limit must be less or equal to AI1 upper limit.

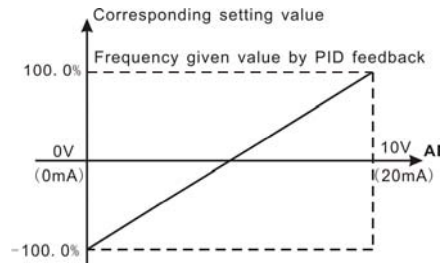

Figure 6.14 Relationship between AI and corresponding setting.

AI1 filter time constant is effective when there are sudden changes or noise in the analog input signal. Responsiveness decreases as the setting increases.

| Function Code | Name | Description | Setting Range | Factory Setting |
|---------------|---------------------------------------|----------------|---------------|-----------------|
| P5.12 | AI2 lower limit | 0.00V~10.00V | 0.00~10.00 | 0.00V |
| P5.13 | AI2 lower limit corresponding setting | -100.0%~100.0% | -100.0~100.0 | 0.0% |
| P5.14 | AI2 upper limit | 0.00V~10.00V | 0.00~10.00 | 10.00V |
| P5.15 | AI2 upper limit corresponding setting | -100.0%~100.0% | -100.0~100.0 | 100.0% |
| P5.16 | AI2 filter time constant | 0.00s~10.00s | 0.00~10.00 | 0.10s |

Please refer to description of AI1. When AI2 is set as 0~20mA current input, the corresponding voltage range is 0~5V.

6.7 P6 Group--Output Terminals

| Function Code | Name | Description | Setting Range | Factory Setting |
|---------------|------------------------|-----------------------|---------------|-----------------|
| P6.00 | Y output selection | Open-collector output | 0~10 | 1 |
| P6.01 | Relay output selection | Relay output | 0~10 | 3 |

OC/Relay output functions are indicated in the following table.

| Setting Value | Function | Description |
|---------------|-------------------------------|---|
| 0 | No output | Output terminal has no function |
| 1 | Run forward | ON: During forward run. |
| 2 | Run reverse | ON: During reverse run. |
| 3 | Fault output | ON: Inverter is in fault status. |
| 4 | FDT reached | Please refer to description of P8.13 and P8.14. |
| 5 | Frequency reached | Please refer to description of P8.15. |
| 6 | Zero speed running | ON: The running frequency of inverter is zero. |
| 7 | Upper frequency limit reached | ON: Running frequency reaches the value of P0.05. |
| 8 | Lower frequency limit reached | ON: Running frequency reaches the value of P0.06. |
| 9~10 | Reserved | Reserved |

Detailed Function Description

| Function Code | Name | Description | Setting Range | Factory Setting |
|---------------|--------------|-------------------------------|---------------|-----------------|
| P6.02 | AO selection | Multifunctional analog output | 0~10 | 0 |

Current (0~20mA) or voltage (0~10V) output can be selected by Jumper J15.

AO functions are indicated in the following table:

| Setting Value | Function | Range |
|---------------|---------------------|---------------------------------------|
| 0 | Running frequency | 0~maximum frequency (P0.04) |
| 1 | Reference frequency | 0~ maximum frequency (P0.04) |
| 2 | Motor speed | 0~2* rated synchronous speed of motor |
| 3 | Output current | 0~2* inverter rated current |
| 4 | Output voltage | 0~1.5* inverter rated voltage |
| 5 | Output power | 0~2* rated power |
| 6 | Output torque | 0~2*rated current |
| 7 | AI1 voltage | 0~10V |
| 8 | AI2 voltage/current | 0~10V/0~20mA |
| 9~10 | Reserved | Reserved |

| Function Code | Name | Description | Setting Range | Factory Setting |
|---------------|-------------------------------------|---------------|---------------|-----------------|
| P6.03 | AO lower limit | 0.0%~100.0% | 0.0~100.0 | 0.0% |
| P6.04 | AO lower limit corresponding output | 0.00V ~10.00V | 0.00~10.00 | 0.00V |
| P6.05 | AO upper limit | 0.0%~100.0% | 0.0~100.0 | 100.0% |
| P6.06 | AO upper limit corresponding output | 0.00V ~10.00V | 0.00~10.00 | 10.00V |

These parameters determine the relationship between analog output voltage/current and the corresponding output value. When the analog output value exceeds the range between lower limit and upper limit, it will output the upper limit or lower limit.

When AO is current output, 1mA is corresponding to 0.5V.

For different applications, the corresponding value of 100.0% analog output is different.

For details, please refer to description of each application.

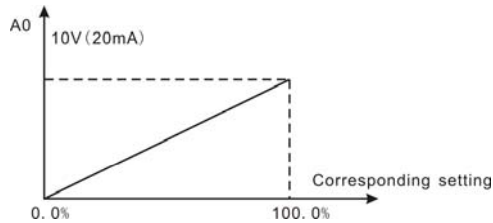

Figure 6.15 Relationship between AO and corresponding setting.

6.8 P7 Group--Display Interface

| Function Code | Name | Description | Setting Range | Factory Setting |
|---------------|---------------|-------------|---------------|-----------------|
| P7.00 | User password | 0~65535 | 0~65535 | 0 |

The password protection function will be valid when set to be any nonzero data. When P7.00 is set to be 00000, user's password set before will be cleared and the password protection function will be disabled.

After the password has been set and becomes valid, the user can not access menu if the user's password is not correct. Only when a correct user's password is input, the user can see and modify the parameters. Please keep user's password in mind.

| Function Code | Name | Description | Setting Range | Factory Setting |
|---------------|------------------------|--|---------------|-----------------|
| P7.01 | LCD language selection | 0: Chinese 1: English | 0~1 | 0 |
| P7.02 | Parameter copy | 0: Invalid 1: Upload from inverter 2: Download to inverter | 0~2 | 0 |

P7.02 will take effect when LCD keypad is used.

1: All value of parameters will be uploaded from inverter to LCD.

2: All value of parameters will be downloaded from LCD to inverter.

Notice: When upload or download operation completes, P7.02 will be set to 0 automatically.

| Function Code | Name | Description | Setting Range | Factory Setting |
|---------------|--|--|---------------|-----------------|
| P7.03 | QUICK/JOG function selection | 0: Jog 1: FDW/REV switching 2: Clear UP/DOWN setting | 0~2 | 0 |

Detailed Function Description

QUICK/JOG is a multifunctional key, whose function can be defined by the value of P7.03.

0: Jog: Press **QUICK/JOG**, the inverter will jog.

1: FWD/REV switching: Press **QUICK/JOG**, the running direction of inverter will reverse. It is only valid if P0.03 is set to be 0.

2: Clear UP/DOWN setting: Press **QUICK/JOG**, the UP/DOWN setting will be cleared.

| Function Code | Name | Description | Setting Range | Factory Setting |
|---------------|------------------------------------|--|---------------|-----------------|
| P7.04 | STOP/RST function option | 0: Valid when keypad control (P0.01=0) 1: Valid when keypad or terminal control (P0.01=0 or 1) 2: Valid when keypad or communication control (P0.01=0 or 2) 3: Always valid | 0~3 | 0 |

Notice:

1. The value of P7.04 only determines the STOP function of **STOP/RST**.
2. The RESET function of **STOP/RST** is always valid.

| Function Code | Name | Description | Setting Range | Factory Setting |
|---------------|--------------------------|---|---------------|-----------------|
| P7.05 | Keypad display selection | 0: Preferential to external keypad 1: Both display, only external key valid. 2: Both display, only local key valid. 3: Both display and key valid. | 0~3 | 0 |

0: When external keypad exists, local keypad will be invalid.

1: Local and external keypad display simultaneously, only the key of external keypad is valid.

2: Local and external keypad display simultaneously, only the key of local keypad is valid.





3: Local and external keypad display simultaneously, both keys of local and external keypad are valid. **Notice: This function should be used cautiously, otherwise it may cause malfunction.**

Notice:

1: When P7.05 is set to be 1, local keypad is valid if external keypad is not connected.

2: When LCD keypad is connected, P7.05 must be set to be 0.

| Function Code | Name | Description | Setting Range | Factory Setting |
|---------------|----------------------------------|-------------|---------------|-----------------|
| P7.06 | Running status display selection | 0~0x7FFF | 0~0x7FFF | 0xFF |

P7.06 defines the parameters that can be displayed by LED in running status. If Bit is 0, the parameter will not be displayed; If Bit is 1, the parameter will be displayed. Press   to scroll through these parameters in right order. Press  +  to scroll through these parameters in left order.

The display content corresponding to each bit of P7.06 is described in the following table:

| BIT7 | BIT6 | BIT5 | BIT4 | BIT3 | BIT2 | BIT1 | BIT0 |
|---------------|------------------------|----------------|----------------|------------------------|-----------------------|---------------------|------------------|
| Output torque | Output power | Rotation speed | Output current | Output voltage | DC bus voltage | Reference frequency | Output frequency |
| BIT15 | BIT14 | BIT13 | BIT12 | BIT11 | BIT10 | BIT9 | BIT8 |
| Reserved | Step No. of multi-step | AI2 | AI1 | Output terminal status | Input terminal status | PID feedback | PID preset |

For example, if user wants to display output voltage, DC bus voltage, Reference frequency, Output frequency, Output terminal status, the value of each bit is as the following table:

| BIT7 | BIT6 | BIT5 | BIT4 | BIT3 | BIT2 | BIT1 | BIT0 |
|-------|-------|-------|-------|-------|-------|------|------|
| 0 | 0 | 0 | 0 | 1 | 1 | 1 | 1 |
| BIT15 | BIT14 | BIT13 | BIT12 | BIT11 | BIT10 | BIT9 | BIT8 |
| 0 | 0 | 0 | 1 | 0 | 0 | 0 | 0 |

The value of P7.06 is 100Fh.

Notice: I/O terminal status is displayed in decimal. For details, please refer to description of P7.18 and P7.19.

| Function Code | Name | Description | Setting Range | Factory Setting |
|---------------|-------------------------------|-------------|---------------|-----------------|
| P7.07 | Stop status display selection | 0~0x1FF | 0~0x1FF | 0xFF |

P7.07 determines the display parameters in stop status. The setting method is similar with P7.06.

The display content corresponding to each bit of P7.07 is described in the following table:

Detailed Function Description

| BIT7 | BIT6 | BIT5 | BIT4 | BIT3 | BIT2 | BIT1 | BIT0 |
|------|------|--------------|------------|------------------------|-----------------------|----------------|---------------------|
| AI2 | AI1 | PID feedback | PID preset | Output terminal status | Input terminal status | DC bus voltage | Reference frequency |

| BIT15 | BIT14 | BIT13 | BIT12 | BIT11 | BIT10 | BIT9 | BIT8 |
|----------|----------|----------|----------|----------|----------|----------|------------------------|
| Reserved | Reserved | Reserved | Reserved | Reserved | Reserved | Reserved | Step No. of multi-step |

| Function Code | Name | Description | Setting Range | Factory Setting |
|---------------|------------------------------|-------------|---------------|-----------------|
| P7.08 | Rectifier module temperature | 0~100.0℃ | | |
| P7.09 | IGBT module temperature | 0~100.0℃ | | |
| P7.10 | Software version | | | |
| P7.11 | Accumulated running time | 0~65535h | | |

Rectify module temperature: Indicates the temperature of rectify module. Overheat protection point of different inverter may be different.

IGBT module temperature: Indicates the temperature of IGBT module. Overheat protection point of different inverter may be different.

Software version: Indicates current software version of DSP.

Accumulated running time: Displays accumulated running time of inverter.

Notice: Above parameters are read only.

| Function Code | Name | Description | Setting Range | Factory Setting |
|---------------|--------------------------|-------------|---------------|-----------------|
| P7.12 | Third latest fault type | 0~24 | | |
| P7.13 | Second latest fault type | 0~24 | | |
| P7.14 | Latest fault type | 0~24 | | |

These parameters record three recent fault types. For details, please refer to description of chapter 7.

| Function Code | Name | Description | Setting Range | Factory Setting | | | | | | | | |
|---------------|---|--|---------------|-----------------|------|------|----|----|----|----|--|--|
| P7.15 | Output frequency at current fault | Output frequency at current fault. | | | | | | | | | | |
| P7.16 | Output current at current fault | Output current at current fault. | | | | | | | | | | |
| P7.17 | DC bus voltage at current fault | DC bus voltage at current fault. | | | | | | | | | | |
| P7.18 | Input terminal status at current fault | <p>This value records ON-OFF input terminal status at current fault. The meaning of each bit is as below:</p> <table border="1"> <tr> <td>BIT3</td> <td>BIT2</td> <td>BIT1</td> <td>BIT0</td> </tr> <tr> <td>S4</td> <td>S3</td> <td>S2</td> <td>S1</td> </tr> </table> <p>1 indicates corresponding input terminal is ON, while 0 indicates OFF. Notice: This value is displayed as decimal.</p> | BIT3 | BIT2 | BIT1 | BIT0 | S4 | S3 | S2 | S1 | | |
| BIT3 | BIT2 | BIT1 | BIT0 | | | | | | | | | |
| S4 | S3 | S2 | S1 | | | | | | | | | |
| P7.19 | Output terminal status at current fault | <p>This value records output terminal status at current fault. The meaning of each bit is as below:</p> <table border="1"> <tr> <td>BIT3</td> <td>BIT2</td> <td>BIT1</td> <td>BIT0</td> </tr> <tr> <td></td> <td>RO</td> <td></td> <td>Y</td> </tr> </table> <p>1 indicates corresponding output terminal is ON, while 0 indicates OFF. Notice: This value is displayed as decimal.</p> | BIT3 | BIT2 | BIT1 | BIT0 | | RO | | Y | | |
| BIT3 | BIT2 | BIT1 | BIT0 | | | | | | | | | |
| | RO | | Y | | | | | | | | | |

6.9 P8 Group--Enhanced Function

| Function Code | Name | Description | Setting Range | Factory Setting |
|---------------|---------------------|-------------|---------------|-----------------|
| P8.00 | Acceleration time 1 | 1.0~3600.0s | 1.0~3600.0 | 20.0s |
| P8.01 | Deceleration time 1 | 1.0~3600.0s | 1.0~3600.0 | 20.0s |

For details, please refer to description of P0.08 and P0.09.

Detailed Function Description

| Function Code | Name | Description | Setting Range | Factory Setting |
|---------------|-----------------------|-------------|---------------|-----------------|
| P8.02 | Jog reference | 0.00~P0.04 | 0.00~ P0.04 | 5.00Hz |
| P8.03 | Jog acceleration time | 0.1~3600.0s | 0.1~3600.0 | Depend on model |
| P8.04 | Jog deceleration time | 0.1~3600.0s | 0.1~3600.0 | Depend on model |

The meaning and factory setting of P8.03 and P8.04 is the same as P0.08 and P0.09. No matter what the value of P1.00 and P1.05 are, jog will start as start directly mode and stop as deceleration to stop mode.

| Function Code | Name | Description | Setting Range | Factory Setting |
|---------------|--------------------------|-------------|---------------|-----------------|
| P8.05 | Skip frequency | 0.00~P0.04 | 0.00~P0.04 | 0.00Hz |
| P8.06 | Skip frequency bandwidth | 0.00~P0.04 | 0.00~P0.04 | 0.00Hz |

By means of setting skip frequency, the inverter can keep away from the mechanical resonance with the load. P8.05 is centre value of frequency to be skipped.

Notice:

1. If P8.06 is 0, the skip function is invalid.
2. If P8.05 is 0, the skip function is invalid no matter what P8.06 is.
3. Operation is prohibited within the skip frequency bandwidth, but changes during acceleration and deceleration are smooth without skip.

The relation between running frequency and reference frequency is shown in following figure.

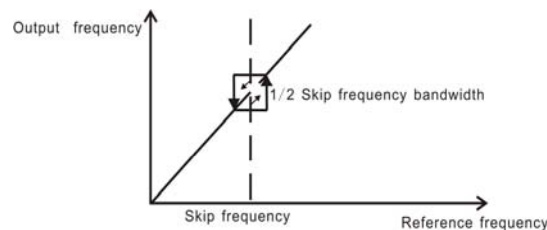

Figure 6.16 Skip frequency diagram.

| Function Code | Name | Description | Setting Range | Factory Setting |
|---------------|-----------------------|-------------|---------------|-----------------|
| P8.07 | Traverse amplitude | 0.0~100.0% | 0.0~100.0 | 0.0% |
| P8.08 | Jitter frequency | 0.0~50.0% | 0.0~50.0 | 0.0% |
| P8.09 | Rise time of traverse | 0.1~3600.0s | 0.1~3600.0 | 5.0s |
| P8.10 | Fall time of traverse | 0.1~3600.0s | 0.1~3600.0 | 5.0s |

Traverse operation is widely used in textile and chemical fiber industry. The typical application is shown in following figure.

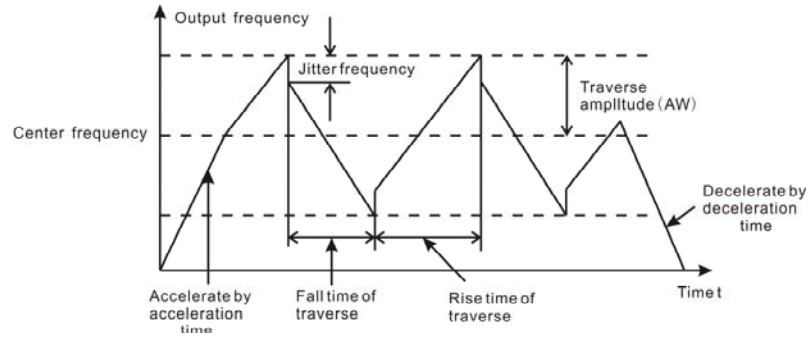

Figure 6.17 Traverse operation diagram.

Center frequency (CF) is reference frequency.

Traverse amplitude (AW) = center frequency (CF) * P8.08%

Jitter frequency = traverse amplitude (AW) * P8.08%

Rise time of traverse: Indicates the time rising from the lowest traverse frequency to the highest traverse frequency.

Fall time of traverse: Indicates the time falling from the highest traverse frequency to the lowest traverse frequency.

Notice:

1. P8.07 determines the output frequency range which is as below:

(1-P8.07%) * reference frequency ≤ output frequency ≤ (1+P8.07%) * reference frequency

2. The output frequency of traverse is limited by upper frequency limit (P0.05) and lower frequency limit (P0.06).

| Function Code | Name | Description | Setting Range | Factory Setting |
|---------------|------------------|-------------|---------------|-----------------|
| P8.11 | Auto reset times | 0~3 | 0~3 | 0 |
| P8.12 | Reset interval | 0.1~100.0s | 0.1~100.0 | 1.0s |

Auto reset function can reset the fault in preset times and interval. When P8.11 is set to be 0, it means "auto reset" is disabled and the protective device will be activated in case of fault.

Notice: The fault such as OUT 1, OUT 2, OUT 3, OH1 and OH2 cannot be reset automatically.

Detailed Function Description

| Function Code | Name | Description | Setting Range | Factory Setting |
|---------------|-----------|-------------|---------------|-----------------|
| P8.13 | FDT level | 0.00~ P0.04 | 0.00~ P0.04 | 50.00Hz |
| P8.14 | FDT lag | 0.0~100.0% | 0.0~100.0 | 5.0% |

when the output frequency reaches a certain preset frequency (FDT level), output terminal will output an ON-OFF signal until output frequency drops below a certain frequency of FDT level (FDT level - FDT lag), as shown in following figure.

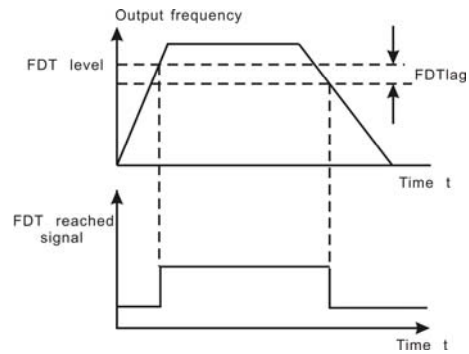

Figure 6.18 FDT level and lag diagram.

| Function Code | Name | Description | Setting Range | Factory Setting |
|---------------|----------------------------------|-----------------------------------|---------------|-----------------|
| P8.15 | Frequency arrive detecting range | 0.0~100.0% (maximum frequency) | 0.0~100.0 | 0.0% |

When output frequency is within the detecting range of reference frequency, an ON-OFF signal will be output.

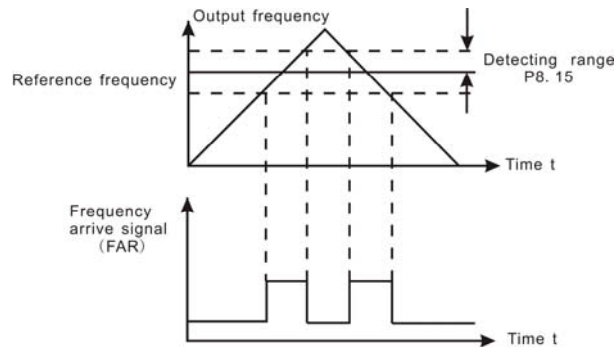

Figure 6.19 Frequency arriving signal diagram.

| Function Code | Name | Description | Setting Range | Factory Setting |
|---------------|-------------------------|--------------|---------------|-----------------|
| P8.16 | Brake threshold voltage | 115.0~140.0% | 115.0~140.0 | Depend on model |

When the DC bus voltage is greater than the value of P8.16, the inverter will start dynamic braking.

Notice:

1. **Factory setting is 120% if rated voltage of inverter is 220V.**
2. **Factory setting is 130% if rated voltage of inverter is 380V.**
3. **The value of P8.16 is corresponding to the DC bus voltage at rated input voltage.**

| Function Code | Name | Description | Setting Range | Default Value |
|---------------|-------------------------------|-------------|---------------|---------------|
| P8.17 | Coefficient of rotation speed | 0.1~999.9% | 0.1~999.9% | 100.0% |

This parameter is used to calibrate the bias between actual mechanical speed and rotation speed. The formula is as below:

$$\text{Actual mechanical speed} = 120 * \text{output frequency} * \text{P8.17} / \text{Number of poles of motor}$$

6.10 P9 Group--PID Control

PID control is a common used method in process control, such as flow, pressure and temperature control. The principle is firstly detect the bias between preset value and feedback value, then calculate output frequency of inverter according to proportional gain, integral and differential time. Please refer to following figure.

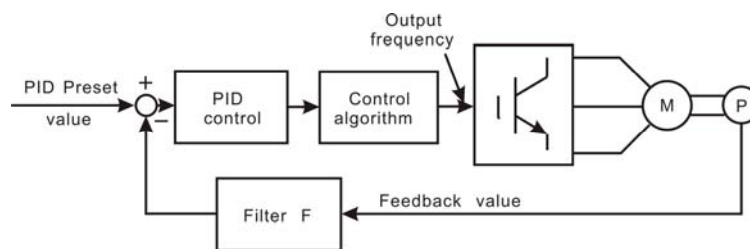

Figure 6.20 PID control diagram.

Detailed Function Description

| Function Code | Name | Description | Setting Range | Factory Setting |
|---------------|-------------------------------|--|---------------|-----------------|
| P9.00 | PID preset source selection | 0: Keypad 1: AI1 2: AI2 3: Communication 4: Multi-step | 0~4 | 0 |
| P9.01 | Keypad PID preset | 0.0%~100.0% | 0.0~100.0 | 0.0% |
| P9.02 | PID feedback source selection | 0: AI1 1: AI2 2: AI1+AI2 3: Communication | 0~3 | 0 |

These parameters are used to select PID preset and feedback source.

Notice:

1. **Preset value and feedback value of PID are percentage value.**
2. **100% of preset value is corresponding to 100% of feedback value.**
3. **Preset source and feedback source must not be same, otherwise PID will be malfunction.**

| Function Code | Name | Description | Setting Range | Factory Setting |
|---------------|----------------------------|----------------------------|---------------|-----------------|
| P9.03 | PID output characteristics | 0: Positive 1: Negative | 0~1 | 0 |

0: Positive. When the feedback value is greater than the preset value, output frequency will be decreased, such as tension control in winding application.

1: Negative. When the feedback value is greater than the preset value, output frequency will be increased, such as tension control in unwinding application.

| Function Code | Name | Description | Setting Range | Factory Setting |
|---------------|------------------------|-------------|---------------|-----------------|
| P9.04 | Proportional gain (Kp) | 0.00~100.00 | 0.00~100.00 | 0.10 |
| P9.05 | Integral time (Ti) | 0.01~10.00s | 0.01~10.00 | 0.10s |
| P9.06 | Differential time (Td) | 0.00~10.00s | 0.00~10.00 | 0.00s |

Optimize the responsiveness by adjusting these parameters while driving an actual load.

Adjusting PID control:

Use the following procedure to activate PID control and then adjust it while monitoring the response.

3. Enabled PID control (P0.03=5)
4. Increase the proportional gain (Kp) as far as possible without creating oscillation.
5. Reduce the integral time (Ti) as far as possible without creating oscillation.
6. Increase the differential time (Td) as far as possible without creating oscillation.

Making fine adjustments:

First set the individual PID control constants, and then make fine adjustments.

- Reducing overshooting

If overshooting occurs, shorten the differential time and lengthen the integral time.

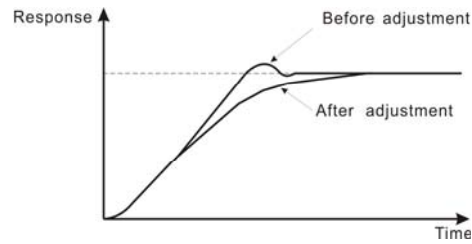

Figure 6.21 Reducing overshooting diagram.

- Rapidly stabilizing control status

To rapidly stabilize the control conditions even when overshooting occurs, shorten the integral time and lengthen the differential time.

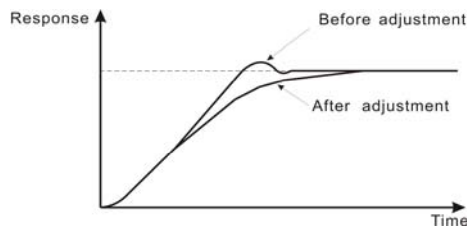

Figure 6.22 Rapidly stabilizing diagram.

- Reducing long-cycle oscillation

If oscillation occurs with a longer cycle than the integral time setting, it means that integral operation is strong. The oscillation will be reduced as the integral time is lengthened.

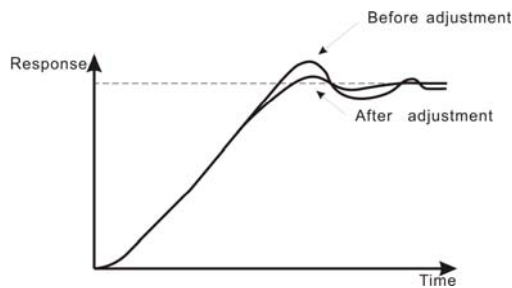

Figure 6.23 Reducing long-cycle oscillation diagram.

- Reducing short-cycle oscillation

If the oscillation cycle is short and oscillation occurs with a cycle approximately the same as the differential time setting, it means that the differential operation is strong. The oscillation will be reduced as the differential time is shortened.

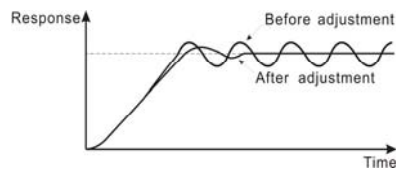

Figure 6.24 Reducing short-cycle oscillation diagram.

If oscillation cannot be reduced even by setting the differential time to 0, then either lower the proportional gain or raise the PID primary delay time constant.

| Function Code | Name | Description | Setting Range | Factory Setting |
|---------------|--------------------|--------------|---------------|-----------------|
| P9.07 | Sampling cycle (T) | 0.01~100.00s | 0.01~100.00 | 0.10s |
| P9.08 | Bias limit | 0.0~100.0% | 0.0~100.0 | 0.0% |

Sampling cycle T refers to the sampling cycle of feedback value. The PI regulator calculates once in each sampling cycle. The bigger the sampling cycle, the slower the response is.

Bias limit defines the maximum bias between the feedback and the preset. PID stops operation when the bias is within this range. Setting this parameter correctly is helpful to improve the system output accuracy and stability.

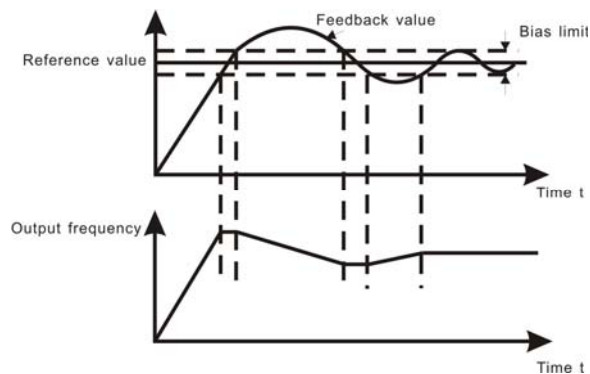

Figure 6.25 Relationship between bias limit and output frequency.

| Function Code | Name | Description | Setting Range | Factory Setting |
|---------------|-------------------------------|-------------|---------------|-----------------|
| P9.09 | Feedback lost detecting value | 0.0~100.0% | 0.0~100.0 | 0.0% |
| P9.10 | Feedback lost detecting time | 0.0~3600.0s | 0.0~3600.0 | 1.0s |

When feedback value is less than P9.09 continuously for the period determined by P9.10, the inverter will alarm feedback lost failure (PIDE).

Notice: 100% of P9.09 is the same as 100% of P9.01.

6.11 PA Group-- Multi-step Speed Control

| Function Code | Name | Description | Setting Range | Factory Setting |
|---------------|--------------------|---------------|---------------|-----------------|
| PA.00 | Multi-step speed 0 | -100.0~100.0% | -100.0~100.0 | 0.0% |
| PA.01 | Multi-step speed 1 | -100.0~100.0% | -100.0~100.0 | 0.0% |
| PA.02 | Multi-step speed 2 | -100.0~100.0% | -100.0~100.0 | 0.0% |
| PA.03 | Multi-step speed 3 | -100.0~100.0% | -100.0~100.0 | 0.0% |
| PA.04 | Multi-step speed 4 | -100.0~100.0% | -100.0~100.0 | 0.0% |
| PA.05 | Multi-step speed 5 | -100.0~100.0% | -100.0~100.0 | 0.0% |
| PA.06 | Multi-step speed 6 | -100.0~100.0% | -100.0~100.0 | 0.0% |
| PA.07 | Multi-step speed 7 | -100.0~100.0% | -100.0~100.0 | 0.0% |

Notice:

- 100% of multi-step speed x corresponds to the maximum frequency (P0.04).**
- If the value of multi-step speed x is negative, the direction of this step will be reverse, otherwise it will be forward.**
- Multi-step speed function has highest priority**

Selection of step is determined by combination of multi-step terminals. Please refer to following figure and table.

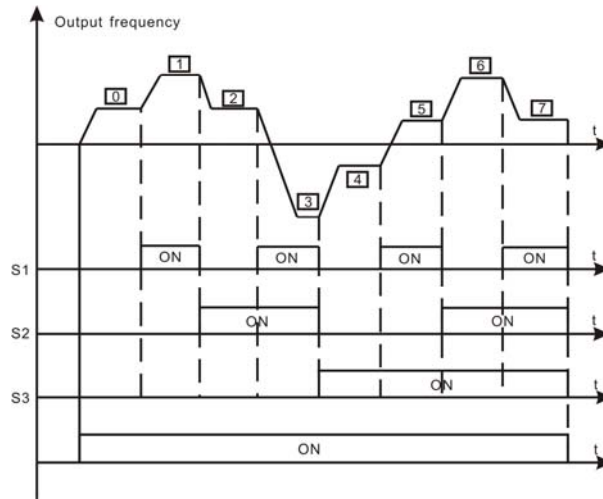

Figure 6.26 Multi-steps speed operating diagram.

| Step | Terminal | Multi-step speed reference1 | Multi-step speed reference2 | Multi-step speed reference3 |
|------|----------|-----------------------------|-----------------------------|-----------------------------|
| 0 | | OFF | OFF | OFF |
| 1 | | ON | OFF | OFF |
| 2 | | OFF | ON | OFF |
| 3 | | ON | ON | OFF |
| 4 | | OFF | OFF | ON |
| 5 | | ON | OFF | ON |
| 6 | | OFF | ON | ON |
| 7 | | ON | ON | ON |

6.12 PB Group-- Protection Function

| Function Code | Name | Description | Setting Range | Factory Setting |
|---------------|---------------------------|---|---------------|-----------------|
| PB.00 | Motor overload protection | 0: Disabled 1: Normal motor 2: Variable frequency motor | 0~2 | 2 |

1: For normal motor, the lower the speed, the poorer the cooling effect. Based on this reason, if output frequency is lower than 30Hz, inverter will reduce the motor overload protection threshold to prevent normal motor from overheat.

2: As the cooling effect of variable frequency motor has nothing to do with running speed, it is not required to adjust the motor overload protection threshold.

| Function Code | Name | Description | Setting Range | Factory Setting |
|---------------|-----------------------------------|--------------|---------------|-----------------|
| PB.01 | Motor overload protection current | 20.0%~120.0% | 20.0~120.0 | 100.0% |

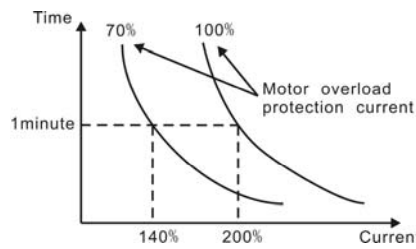

Figure 6.27 Motor overload protection curve.

The value can be determined by the following formula:

Motor overload protection current = (motor rated current / inverter rated current) * 100%

Notice:

1. This parameter is normally used when rated power of inverter is greater than rated power of motor.
2. Motor overload protection time: 60s with 200% of rated current. For details, please refer to above figure.

| Function Code | Name | Description | Setting Range | Factory Setting |
|---------------|----------------------------|--------------|---------------|-----------------|
| PB.02 | Threshold of trip-free | 70.0~110.0% | 70.0~110.0 | 80.0% |
| PB.03 | Decrease rate of trip-free | 0.00Hz~P0.04 | 0.00Hz~P0.04 | 0.00Hz |

If PB.03 is set to be 0, the trip-free function is invalid.

Trip-free function enables the inverter to perform low-voltage compensation when DC bus voltage drops below PB.02. The inverter can continue to run without tripping by reducing its output frequency and feedback energy via motor.

Notice: If PB.03 is too big, the feedback energy of motor will be too large and may cause over-voltage fault. If PB.03 is too small, the feedback energy of motor will be too small to achieve voltage compensation effect. So please set PB.03 according to load inertia and the actual load.

| Function Code | Name | Description | Setting Range | Factory Setting |
|---------------|-------------------------------------|---------------------------|---------------|------------------------|
| PB.04 | Over-voltage stall protection | 0: Disabled 1: Enabled | 0~1 | 1 |
| PB.05 | Over-voltage stall protection point | 110~150% | 110~150 | 380V:130% 220V:120% |

Detailed Function Description

During deceleration, the motor's decelerating rate may be lower than that of inverter's output frequency due to the load inertia. At this time, the motor will feed the energy back to the inverter, resulting in DC bus voltage rise. If no measures taken, the inverter will trip due to over voltage.

During deceleration, the inverter detects DC bus voltage and compares it with over-voltage stall protection point. If DC bus voltage exceeds PB.05, the inverter will stop reducing its output frequency. When DC bus voltage become lower than PB.05, the deceleration continues, as shown in following figure.

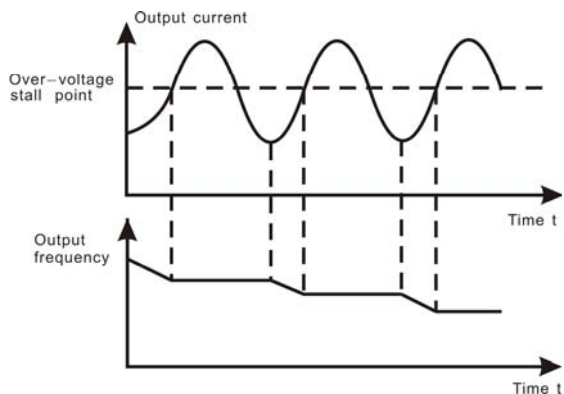

Figure 6.28 Over-voltage stall function.

| Function Code | Name | Description | Setting Range | Factory Setting |
|---------------|---|-----------------|---------------|--------------------------------|
| PB.06 | Auto current limiting threshold | 50~200% | 50~200 | G Model: 160% P Model: 120% |
| PB.07 | Frequency decrease rate when current limiting | 0.00~100.00Hz/s | 0.00~100.00 | 10.00Hz/s |

Auto current limiting is used to limit the current of inverter smaller than the value determined by PB.06 in real time. Therefore the inverter will not trip due to surge over-current. This function is especially useful for the applications with big load inertia or step change of load.

PB.06 is a percentage of the inverter's rated current.

PB.07 defines the decrease rate of output frequency when this function is active. If PB.06 is too small, overload fault may occur. If it is too big, the frequency will change too sharply and therefore, the feedback energy of motor will be too large and may cause over-voltage fault. This function is always enabled during acceleration or deceleration.

Notice:

1. During auto current limiting process, the inverter's output frequency may change; therefore, it is recommended not to enable the function when requires the inverter's output frequency stable.
2. During auto current limiting process, if PB.06 is too low, the overload capacity will be impacted.

Please refer to following figure.

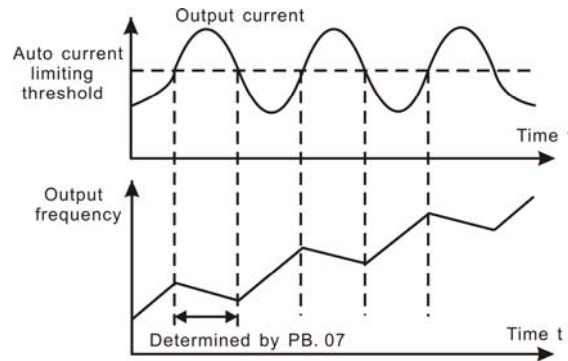

Figure 6.29 Current limiting protection function.

6.13 PC Group--Serial Communication

| Function Code | Name | Description | Setting Range | Factory Setting |
|---------------|---------------|-------------|---------------|-----------------|
| PC.00 | Local address | 1~247 | 0~247 | 1 |

This parameter determines the slave address used for communication with master. The value "0" is the broadcast address.

| Function Code | Name | Description | Setting Range | Factory Setting |
|---------------|---------------------|--|---------------|-----------------|
| PC.01 | Baud rate selection | 0: 1200BPS 1: 2400BPS 2: 4800BPS 3: 9600BPS 4: 19200BPS 5: 38400BPS | 0~5 | 3 |

This parameter can set the data transmission rate during serial communication.

Notice: The baud rate of master and slave must be the same.

Detailed Function Description

| Function Code | Name | Description | Setting Range | Factory Setting |
|---------------|-------------|-------------|---------------|-----------------|
| PC.02 | Data format | 0~17 | 0~17 | 0 |

This parameter defines the data format used in serial communication protocol.

- 0: RTU, 1 start bit, 8 data bits, no parity check, 1 stop bit.
- 1: RTU, 1 start bit, 8 data bits, even parity check, 1 stop bit.
- 2: RTU, 1 start bit, 8 data bits, odd parity check, 1 stop bit.
- 3: RTU, 1 start bit, 8 data bits, no parity check, 2 stop bits.
- 4: RTU, 1 start bit, 8 data bits, even parity check, 2 stop bits.
- 5: RTU, 1 start bit, 8 data bits, odd parity check, 2 stop bits.
- 6: ASCII, 1 start bit, 7 data bits, no parity check, 1 stop bit.
- 7: ASCII, 1 start bit, 7 data bits, even parity check, 1 stop bit.
- 8: ASCII, 1 start bit, 7 data bits, odd parity check, 1 stop bit.
- 9: ASCII, 1 start bit, 7 data bits, no parity check, 2 stop bits.
- 10: ASCII, 1 start bit, 7 data bits, even parity check, 2 stop bits.
- 11: ASCII, 1 start bit, 7 data bits, odd parity check, 2 stop bits.
- 12: ASCII, 1 start bit, 8 data bits, no parity check, 1 stop bit.
- 13: ASCII, 1 start bit, 8 data bits, even parity check, 1 stop bit.
- 14: ASCII, 1 start bit, 8 data bits, odd parity check, 1 stop bit.
- 15: ASCII, 1 start bit, 8 data bits, no parity check, 2 stop bits.
- 16: ASCII, 1 start bit, 8 data bits, even parity check, 2 stop bits.
- 17: ASCII, 1 start bit, 8 data bits, odd parity check, 2 stop bits.

| Function Code | Name | Description | Setting range | Factory Setting |
|---------------|--------------------------|-------------|---------------|-----------------|
| PC.03 | Communication delay time | 0~200ms | 0~200 | 5ms |

This parameter can be used to set the response delay in communication in order to adapt to the MODBUS master. In RTU mode, the actual communication delay should be no less than 3.5 characters' interval; in ASCII mode, 1ms.

| Function Code | Name | Description | Setting Range | Factory Setting |
|---------------|-----------------------------|-----------------------------|---------------|-----------------|
| PC.04 | Communication timeout delay | 0.0: Disabled 0.1~100.0s | 0~100.0 | 0.0s |

When the value is zero, this function will be disabled. When communication interruption is longer than the non-zero value of PC.04, the inverter will alarm communication error (CE).

| Function Code | Name | Description | Setting Range | Factory Setting |
|---------------|----------------------------|--|---------------|-----------------|
| PC.05 | Communication error action | 0: Alarm and coast to stop 1: No alarm and continue to run 2: No alarm but stop according to P1.05 (if P0.01=2) 3: No alarm but stop according to P1.05 | 0~3 | 1 |

- 0: When communication error occurs, inverter will alarm (CE) and coast to stop.
- 1: When communication error occurs, inverter will omit the error and continue to run.
- 2: When communication error occurs, if P0.01=2, inverter will not alarm but stop according to stop mode determined by P1.05. Otherwise it will omit the error.
- 3: When communication error occurs, inverter will not alarm but stop according to stop mode determined by P1.05.

| Function Code | Name | Description | Setting Range | Factory Setting |
|---------------|-----------------|--|---------------|-----------------|
| PC.06 | Response action | Unit's place of LED 0: Response to writing 1: No response to writing Ten's place of LED 0: Reference not saved when power off 1: Reference saved when power off | 0~1 | 0~1 |

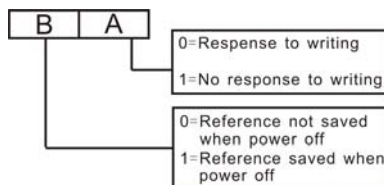

Figure 6.30 Meaning of PC.06.

- A stands for: Unit's place of LED.
- B stands for: Ten's place of LED

6.14 PD Group—Supplementary Function

| Function Code | Name | Description | Setting Range | Factory Setting |
|---------------|---|-------------|---------------|-----------------|
| PD.00 | Low-frequency threshold of restraining oscillation | 0~500 | 0~500 | 5 |
| PD.01 | High-frequency threshold of restraining oscillation | 0~500 | 0~500 | 100 |

This function is valid only when PD.04 is set to be 0. The smaller the value of PD.00 and PD.01, the stronger the restraining effect.

Notice: Most motor may have current oscillation at some frequency point. Please be cautious to adjust these parameters to weaken oscillation.

| Function Code | Name | Description | Setting Range | Factory Setting |
|---------------|--------------------------------------|-------------|---------------|-----------------|
| PD.02 | Amplitude of restraining oscillation | 0~10000 | 0~10000 | 5000 |

This parameter is used to limit the strength of restraining oscillation. If the value of PD.02 is too big, it may cause inverter over current. It should be set a little bit smaller for large power motor, vice versa.

| Function Code | Name | Description | Setting Range | Factory Setting |
|---------------|-------------------------------------|-------------|---------------|-----------------|
| PD.03 | Boundary of restraining oscillation | 0.0~P0.04 | 0.0HZ~P0.04 | 12.5HZ |

If output frequency is greater than PD.03, PD.00 takes effect, otherwise PD.01 takes effect.

| Function Code | Name | Description | Setting Range | Factory Setting |
|---------------|-------------------------|---------------------------|---------------|-----------------|
| PD.04 | Restraining oscillation | 0: Enabled 1: Disabled | 0~1 | 0 |

Motor always has current oscillation when its load is light. This will cause abnormal operation even over-current. For details, please refer to description of PD.00~PD.03.

| Function Code | Name | Description | Setting Range | Factory Setting |
|---------------|----------|---|---------------|-----------------|
| PD.05 | PWM mode | 0: PWM mode 1 1: PWM mode 2 2: PWM mode 3 | 0~2 | 0 |

The features of each mode, please refer the following table:

| Mode | Noise in lower frequency | Noise in higher frequency | Others |
|------------|--------------------------|---------------------------|---|
| PWM mode 1 | Low | high | |
| PWM mode 2 | low | | Need to be derated, because of higher temperature rise. |
| PWM mode 3 | high | | Can more effectively restrain the oscillation |

| Function Code | Name | Description | Setting Range | Factory Setting |
|---------------|-----------------------|--|----------------|-----------------|
| PD.06 | Torque setting source | 0: Keypad 1: AI1 2: AI2 3: AI1+AI2 4: Multi-step setting 5: Communication | 0~5 | 0 |
| PD.07 | Keypad torque setting | -100.0%~100.0% | -100.0%~100.0% | 50.0% |

- When torque control takes effect,
 - if $T_{set} > T_{load}$, output frequency will increase continuously until it reaches upper frequency limit.
 - If $T_{set} < T_{load}$, output frequency will decrease continuously until it reaches lower frequency limit.
 - Inverter can run at any frequency between upper and lower frequency limit only when $T_{set} = T_{load}$.
- Torque control can be switched to speed control, vice versa.
 - Switching by multifunctional terminal: For example, if torque control is enabled ($P0.00=2$), torque setting source is AI1, the value of multifunction terminal S5 is set to 20 (Disable torque control). When S5 is valid, control mode will switch from torque control to speed control, vice versa.
 - When running at torque control mode, press **STOP/RS1**, it will switch to speed control automatically.
- If torque setting is positive, inverter will run forward; otherwise it will run reverse.

Notice:

1. **When running at torque control mode, the acceleration time has nothing to do with P0.08.**
2. **The 100% of torque setting is corresponding to 100% of P3.07 (Torque limit). For example, if torque setting source is keypad (PD.06=0), PD.07=80% and P3.07=90%, then**
Actual torque setting = 80% (PD.07) * 90% (P3.07) = 72%.

Detailed Function Description

| Function Code | Name | Description | Setting Range | Factory Setting |
|---------------|---------------------------------|--|---------------|-----------------|
| PD.08 | Upper frequency limit selection | 0: Keypad 1: AI1 2: AI2 3: Multi-step setting 4: Communication | 0~4 | 0 |

The 100% of this parameter is corresponding to 100% of P0.04 (maximum frequency).

When running at torque control mode, output frequency can be adjusted by changing upper frequency limit.

| Function Code | Name | Description | Setting Range | Factory Setting |
|---------------|---------------------------------|---|---------------|-----------------|
| PD.09 | Auto current limiting selection | 0: Enabled 1: Disabled when constant speed | 0~1 | 0 |

Auto current limiting function is used to prevent inverter trip over-current from surge current. It is especially useful for the applications with big load inertia or step change of load. This function is always enabled during acceleration or deceleration period.

Notice: During auto current limiting process, the inverter's output frequency may change; therefore, it is recommended not to enable the function when output frequency need to be stable.

6.15 PE Group—Factory Setting

This group is the factory-set parameter group. The user DO NOT try to open these group parameters, otherwise it will cause the inverter abnormal operation or damage.

7. TROUBLE SHOOTING

7.1 Fault and Trouble shooting

| Fault Code | Fault Type | Reason | Solution |
|------------|--|--|--|
| OUT1 | IGBT Ph-U fault | 1. Acc/Dec time is too short. 2. IGBT module fault. 3. Malfunction caused by interference. 4. Grounding is not properly. | 1. Increase Acc/Dec time. 2. Ask for support. 3. Inspect external equipment and eliminate interference. |
| OUT2 | IGBT Ph-V fault | | |
| OUT3 | IGBT Ph-W fault | | |
| OC1 | Over-current when acceleration | 1. Short-circuit or ground fault occurred at inverter output. 2. Load is too heavy or Acc/Dec time is too short. 3. V/F curve is not suitable. 4. Sudden change of load. | 1. Inspect whether motor damaged, insulation worn or cable damaged. 2. Increase Acc/Dec time or select bigger capacity inverter. 3. Check and adjust V/F curve. Check the load. |
| OC2 | Over-current when deceleration | | |
| OC3 | Over-current when constant speed running | | |
| OV1 | Over-voltage when acceleration | 1. Dec time is too short and regenerative energy from the motor is too large. 2. Input voltage is too high. | 1. Increase Dec time or connect braking resistor 2. Decrease input voltage within specification. |
| OV2 | Over-voltage when deceleration | | |
| OV3 | Over-voltage when constant speed running | | |
| UV | DC bus Under-voltage | 1. Open phase occurred with power supply. 2. Momentary power loss occurred 3. Wiring terminals for input power supply are loose. 4. Voltage fluctuations in power supply are too large. | Inspect the input power supply or wiring. |
| OL1 | Motor overload | 1. Motor drive heavy load at low speed for a long time. 2. Improper V/F curve 3. Improper motor's overload protection threshold (PB.01) 4. Sudden change of load. | 1. Select variable frequency motor. 2. Check and adjust V/F curve. 3. Check and adjust PB.01 4. Check the load. |

Trouble Shooting

| | | | |
|-----|-------------------------|---|---|
| OL2 | Inverter overload | <ol style="list-style-type: none"> 1. Load is too heavy or Acc/Dec time is too short. 2. Improper V/F curve 3. Capacity of inverter is too small. | <ol style="list-style-type: none"> 1. Increase Acc/Dec time or select bigger capacity inverter. 2. Check and adjust V/F curve. 3. Select bigger capacity inverter. |
| SPI | Input phase failure | <ol style="list-style-type: none"> 1. Open-phase occurred in power supply. 2. Momentary power loss occurred. 3. Wiring terminals for input power supply are loose. 4. Voltage fluctuations in power supply are too large. 5. Voltage balance between phase is bad. | Check the wiring, installation and power supply. |
| SPO | Output phase failure | <ol style="list-style-type: none"> 1. There is a broken wire in the output cable 2. There is a broken wire in the motor winding. 3. Output terminals are loose. | Check the wiring and installation. |
| EF | External fault | Sx: External fault input terminal take effect. | Inspect external equipment. |
| OH1 | Rectify overheat | <ol style="list-style-type: none"> 1. Ambient temperature is too high. 2. Near heat source. 3. Cooling fans of inverter stop or damaged. 4. Obstruction of ventilation channel 5. Carrier frequency is too high. | <ol style="list-style-type: none"> 1. Install cooling unit. 2. Remove heat source. 3. Replace cooling fan 4. Clear the ventilation channel. 5. Decrease carrier frequency. |
| OH2 | IGBT overheat | | |
| CE | Communication fault | <ol style="list-style-type: none"> 1. Improper baud rate setting. 2. Receive wrong data. 3. Communication is interrupted for Long time | <ol style="list-style-type: none"> 1. Set proper baud rate. 2. Check communication devices and signals. |
| ITE | Current detection fault | <ol style="list-style-type: none"> 1. Wires or connectors of control board are loose 2. Hall sensor is damaged. 3. Amplifying circuit is abnormal. | <ol style="list-style-type: none"> 1. Check the wiring. 2. Ask for support. |
| TE | Autotuning fault | <ol style="list-style-type: none"> 1. Improper setting of motor rated parameters. 2. Overtime of autotuning. | <ol style="list-style-type: none"> 1. Set rated parameters according to motor nameplate. 2. Check motor's wiring. |
| EEP | EEPROM fault | 1. R/W fault of control parameters | Press STOP/RESET to reset Ask for support |

| | | | |
|------|--------------------|--|---|
| PIDE | PID feedback fault | 1. PID feedback disconnected. 2. PID feedback source disappears. | 1. Inspect PID feedback signal wire. 2. Inspect PID feedback source. |
| BCE | Brake unit fault | 1. Braking circuit failure or brake tube damaged. 2. Too low resistance of externally connected braking resistor. | 1. Inspect braking unit, replace braking tube. 2. Increase braking resistance. |
| | Factory Reserved | | |

7.2 Common Faults and Solutions

Inverter may have following faults or malfunctions during operation, please refer to the following solutions.

No display after power on:

- Inspect whether the voltage of power supply is the same as the inverter rated voltage or not with multi-meter. If the power supply has problem, inspect and solve it.
- Inspect whether the three-phase rectify bridge is in good condition or not. If the rectification bridge is burst out, ask for support.
- Check the CHARGE light. If the light is off, the fault is mainly in the rectify bridge or the buffer resistor. If the light is on, the fault may be lies in the switching power supply. Please ask for support.

Power supply air switch trips off when power on:

- Inspect whether the input power supply is grounded or short circuit. Please solve the problem.
- Inspect whether the rectify bridge has been burnt or not. If it is damaged, ask for support.

Motor doesn't move after inverter running:

- Inspect if there is balanced three-phase output among U, V, W. If yes, then motor could be damaged, or mechanically locked. Please solve it.
- If the output is unbalanced or lost, the inverter drive board or the output module may be damaged, ask for support..

Inverter displays normally when power on, but switch at the input side trips when running:

- Inspect whether the output side of inverter is short circuit. If yes, ask for support.
- Inspect whether ground fault exists. If yes, solve it.
- If trip happens occasionally and the distance between motor and inverter is too far, it is recommended to install output AC reactor.

8. MAINTENANCE



WARNING

- Maintenance must be performed according to designated maintenance methods.
- Maintenance, inspection and replacement of parts must be performed only by authorized personnel.
- After turning off the main circuit power supply, waiting for 10 minutes before performance maintenance or inspection.
- DO NOT directly touch components or devices of PCB board. Otherwise inverter can be damaged by electrostatic.
- After maintenance, all screws must be tightened.

8.1 Daily Maintenance

In order to prevent the fault of inverter to make it operate smoothly in high-performance for a long time, user must inspect the inverter periodically (within half year). The following table indicates the inspection content.

| Items to be checked | Main inspections | | Criteria |
|-----------------------|--|--|---|
| | Inspection content | Frequency | Means/methods |
| Operation environment | (1) temperature, humidity (2)dust, vapor, leakage (3)gases | (1)point thermometer, hygrometer (2)observation (3)visual examination and smelling | (1)ambient temperature shall be lower than 40℃, otherwise, the rated values should be decreased. Humidity shall meet the requirement (2)no dust accumulation, no traces of water leakage and no condensate. (3)no abnormal color and smell. |
| Inverter | (1)vibration (2)cooling and heating (3)noise | (2)point thermometer comprehensive observation (3)listening | (1)smooth operation without vibration. (2)fan is working in good condition. Speed and air flow are normal. No abnormal heat. (3)No abnormal noise |

| | | | |
|-----------------------------|---|--|--|
| Motor | (1)vibration (2)heat (3)noise | (1) comprehensive observation Listening (2)point thermometer (3)listening | (1)No abnormal vibration and no abnormal noise. (2)No abnormal heat. (3)No abnormal noise. |
| Operation status parameters | (1)power input voltage (2)inverter output voltage (3)inverter output current (4)internal temperature | (1)voltmeter (2)rectifying voltmeter (3)ammeter (4)point thermometer | (1)satisfying the specification (2)satisfying the specification (3)satisfying the specification (4)temperature rise is lower than 40℃ |

8.2 Periodic Maintenance

Customer should check the drive every 3 months or 6 months according to the actual environment

1. Check whether the screws of control terminals are loose. If so, tighten them with a screwdriver;
2. Check whether the main circuit terminals are properly connected; whether the mains cables are over heated;
3. Check whether the power cables and control cables are damaged, check especially for any wear on the cable tube;
4. Check whether the insulating tapes around the cable lugs are stripped;
5. Clean the dust on PCBs and air ducts with a vacuum cleaner;
6. For drives that have been stored for a long time, it must be powered on every 2 years. When supplying AC power to the drive, use a voltage regulator to raise the input voltage to rated input voltage gradually. The drive should be powered for 5 hours without load.
7. Before performing insulation tests, all main circuit input/output terminals should be short-circuited with conductors. Then proceed insulation test to the ground. Insulation test of single main circuit terminal to ground is forbidden; otherwise the drive might be damaged. Please use a 500V Mega-Ohm-Meter.
8. Before the insulation test of the motor, disconnect the motor from the drive to avoid damaging it.

8.3 Replacement of wearing parts

Fans and electrolytic capacitors are wearing part, please make periodic replacement to ensure long term, safety and failure-free operation. The replacement periods are as follows:

- ◆ Fan: Must be replaced when using up to 20,000 hours;
- ◆ Electrolytic Capacitor: Must be replaced when using up to 30,000~40, 000 hours.

8.4 Warranty

The manufacturer warrants its products for a period of 12 months from the date of purchase.

9. LIST OF FUNCTION PARAMETERS

Notice:

- PE group is factory reserved, users are forbidden to access these parameters.
- The column "Modify" determines the parameter can be modified or not.
 "○" indicates that this parameter can be modified all the time.
 "⊙" indicates that this parameter cannot be modified during the inverter is running.
 "●" indicates that this parameter is read only.
- "Factory Setting" indicates the value of each parameter while restoring the factory parameters, but those detected parameters or record values cannot be restored.

| Function Code | Name | Description | Factory Setting | Modify | Serial No. |
|---------------------------------|----------------------------|--|-----------------|--------|------------|
| P0 Group: Basic Function | | | | | |
| P0.00 | Control mode selection | 0: Sensorless vector control 1: V/F control 2: Torque control | 0 | ⊙ | 0 |
| P0.01 | Run command source | 0: Keypad (LED extinguishes) 1: Terminal (LED flickers) 2: Communication (LED lights up) | 0 | ⊙ | 1 |
| P0.02 | UP/DOWN setting | 0: Valid, save UP/DOWN value when power off 1: Valid, do not save UP/DOWN value when power off 2: Invalid 3: Valid during running, clear when stop. | 0 | ○ | 2 |
| P0.03 | Frequency A command source | 0: Keypad 1: AI1 2: AI2 3: AI1+AI2 4: Multi-Step speed 5: PID 6: Communication | 0 | ○ | 3 |
| P0.04 | Maximum frequency | 10.00~600.00Hz | 50.00Hz | ⊙ | 4 |
| P0.05 | Upper frequency limit | P0.06~ P0.04 | 50.00Hz | ○ | 5 |

List of Function Parameters

| Function Code | Name | Description | Factory Setting | Modify | Serial No. |
|---|---------------------------------|---|-----------------|--------|------------|
| P0.06 | Lower frequency limit | 0.00 Hz ~ P0.05 | 0.00Hz | ○ | 6 |
| P0.07 | Keypad reference frequency | 0.00 Hz ~ P0.04 | 50.00Hz | ○ | 7 |
| P0.08 | Acceleration time 0 | 0.0~3600.0s | Depend on model | ○ | 8 |
| P0.09 | Deceleration time 0 | 0.0~3600.0s | Depend on model | ○ | 9 |
| P0.10 | Running direction selection | 0: Forward 1: Reverse 2: Forbid reverse | 0 | ◎ | 10 |
| P0.11 | Carrier frequency | 1.0~15.0kHz | Depend on model | ○ | 11 |
| P0.12 | Motor parameters autotuning | 0: No action 1: Rotation autotuning 2: Static autotuning | 0 | ◎ | 12 |
| P0.13 | Restore parameters | 0: No action 1: Restore factory setting 2: Clear fault records | 0 | ◎ | 13 |
| P0.14 | AVR function | 0: Disabled 1: Enabled all the time 2: Disabled during deceleration | 2 | ○ | 14 |
| P1 Group: Start and Stop Control | | | | | |
| P1.00 | Start Mode | 0: Start directly 1: DC braking and start | 0 | ◎ | 15 |
| P1.01 | Starting frequency | 0.00~10.00Hz | 0.00Hz | ○ | 16 |
| P1.02 | Hold time of starting frequency | 0.0~50.0s | 0.0s | ○ | 17 |
| P1.03 | DC Braking current before start | 0.0~150.0% | 0.0% | ○ | 18 |
| P1.04 | DC Braking time before start | 0.0~50.0s | 0.0s | ○ | 19 |

List of Function Parameters

| Function Code | Name | Description | Factory Setting | Modify | Serial No. |
|-----------------------------------|----------------------------------|---|-------------------|--------|------------|
| P1.05 | Stop mode | 0: Deceleration to stop 1: Coast to stop | 0 | ○ | 20 |
| P1.06 | Starting frequency of DC braking | 0.00~P0.04 | 0.00Hz | ○ | 21 |
| P1.07 | Waiting time before DC braking | 0.0~50.0s | 0.0s | ○ | 22 |
| P1.08 | DC braking current | 0.0~150.0% | 0.0% | ○ | 23 |
| P1.09 | DC braking time | 0.0~50.0s | 0.0s | ○ | 24 |
| P1.10 | Dead time of FWD/REV | 0.0~3600.0s | 0.0s | ○ | 25 |
| P1.11 | FWD/REV enable when power on | 0: Disabled 1: Enabled | 0~1 | ○ | 26 |
| P1.12 | Reserved | | 0 | ⊙ | 27 |
| P2 Group: Motor Parameters | | | | | |
| P2.00 | G/P option | 0: G model 1: P model | Depend on model | ⊙ | 28 |
| P2.01 | Motor rated power | 0.4~900.0kW | Depend on model | ⊙ | 29 |
| P2.02 | Motor rated frequency | 0.01Hz~P0.04 | 50.00Hz | ⊙ | 30 |
| P2.03 | Motor rated speed | 0~36000rpm | Depend on model | ⊙ | 31 |
| P2.04 | Motor rated voltage | 0~2000V | Depend on model | ⊙ | 32 |
| P2.05 | Motor rated current | 0.8~2000.0A | Depend on model | ⊙ | 33 |
| P2.06 | Motor stator resistance | 0.001~65.535Ω | Depend on model | ○ | 34 |
| P2.07 | Motor rotor resistance | 0.001~65.535Ω | Depend on model I | ○ | 35 |

List of Function Parameters

| Function Code | Name | Description | Factory Setting | Modify | Serial No. |
|---------------------------------|------------------------------|---|-----------------|--------|------------|
| P2.08 | Motor leakage inductance | 0.1~6553.5mH | Depend on model | ○ | 36 |
| P2.09 | Motor mutual inductance | 0.1~6553.5mH | Depend on model | ○ | 37 |
| P2.10 | Current without load | 0.01~655.35A | Depend on model | ○ | 38 |
| P3 Group: Vector Control | | | | | |
| P3.00 | ASR proportional gain K_p1 | 0~100 | 20 | ○ | 39 |
| P3.01 | ASR integral time K_i1 | 0.01~10.00s | 0.50s | ○ | 40 |
| P3.02 | ASR switching point 1 | 0.00Hz~P3.05 | 5.00Hz | ○ | 41 |
| P3.03 | ASR proportional gain K_p2 | 0~100 | 15 | ○ | 42 |
| P3.04 | ASR integral time K_i2 | 0.01~10.00s | 1.00s | ○ | 43 |
| P3.05 | ASR switching point 2 | P3.02~P0.04 | 10.00Hz | ○ | 44 |
| P3.06 | Slip compensation rate of VC | 50.0~200.0% | 100% | ○ | 45 |
| P3.07 | Torque limit | 0.0~200.0% | 150.0% | ○ | 46 |
| P4 Group: V/F Control | | | | | |
| P4.00 | V/F curve selection | 0: Linear curve 1: Torque_stepdown curve (2.0 order) | 0 | ◎ | 47 |
| P4.01 | Torque boost | 0.0%: (auto) 0.1%~10.0% | 0.0% | ○ | 48 |
| P4.02 | Torque boost cut-off | 0.0%~50.0% (motor rated frequency) | 20.0% | ◎ | 49 |
| P4.03 | V/F Slip compensation limit | 0.00~200.0% | 0.0% | ○ | 50 |
| P4.04 | Auto energy saving selection | 0: Disabled 1: Enabled | 0 | ◎ | 51 |

List of Function Parameters

| Function Code | Name | Description | Factory Setting | Modify | Serial No. |
|----------------------------------|---------------------------------------|--|-----------------|--------|------------|
| P4.05 | Reserved | | | ● | 52 |
| P5 Group: Input Terminals | | | | | |
| P5.00 | S1 terminal function | 0: Invalid 1: Forward 2: Reverse 3: 3-wire control 4: JOG forward 5: JOG reverse | 1 | ⊙ | 53 |
| P5.01 | S2 terminal function | 6: Coast to stop 7: Reset fault 8: External fault input 9: UP command 10: DOWN command | 4 | ⊙ | 54 |
| P5.02 | S3 terminal function | 11: Clear UP/DOWN 12: Multi-step speed reference 1 13: Multi-step speed reference 2 14: Multi-step speed reference 3 15: ACC/DEC time selection 16: Pause PID | 7 | ⊙ | 55 |
| P5.03 | S4 terminal function | 17: Pause traverse operation 18: Reset traverse operation 19: ACC/DEC ramp hold 20: Disable torque control 21: UP/DOWN invalid temporarily 22-25: reserved | 0 | ⊙ | 56 |
| P5.04 | ON/OFF filter times | 1~10 | 5 | ○ | 57 |
| P5.05 | FWD/REV control mode | 0: 2-wire control mode 1 1: 2-wire control mode 2 2: 3-wire control mode 1 3: 3-wire control mode 2 | 0 | ⊙ | 58 |
| P5.06 | UP/DOWN setting change rate | 0.01~50.00Hz/s | 0.50 Hz/s | ○ | 59 |
| P5.07 | A11 lower limit | 0.00V~10.00V | 0.00V | ○ | 60 |
| P5.08 | A11 lower limit corresponding setting | -100.0%~100.0% | 0.0% | ○ | 61 |
| P5.09 | A11 upper limit | 0.00V~10.00V | 10.00V | ○ | 62 |

List of Function Parameters

| Function Code | Name | Description | Factory Setting | Modify | Serial No. |
|-----------------------------------|---------------------------------------|--|-----------------|--------|------------|
| P5.10 | AI1 upper limit corresponding setting | -100.0%~100.0% | 100.0% | O | 63 |
| P5.11 | AI1 filter time constant | 0.00s~10.00s | 0.10s | O | 64 |
| P5.12 | AI2 lower limit | 0.00V~10.00V | 0.00V | O | 65 |
| P5.13 | AI2 lower limit corresponding setting | -100.0%~100.0% | 0.0% | O | 66 |
| P5.14 | AI2 upper limit | 0.00V~10.00V | 10.00V | O | 67 |
| P5.15 | AI2 upper limit corresponding setting | -100.0%~100.0% | 100.0% | O | 68 |
| P5.16 | AI2 filter time constant | 0.00s~10.00s | 0.10s | O | 69 |
| P6 Group: Output Terminals | | | | | |
| P6.00 | Y output selection | 0: No output 1: Run forward 2: Run reverse 3: Fault output 4: FDT reached 5: Frequency reached 6: Zero speed running 7: Upper frequency limit reached 8: Lower frequency limit reached 9~10: reserved | 1 | O | 70 |
| P6.01 | Relay output selection | | 3 | O | 71 |
| P6.02 | AO selection | 0: Running frequency 1: Reference frequency 2: Motor speed 3: Output current 4: Output voltage 5: Output power 6: Output torque 7: AI1 voltage 8: AI2 voltage/current 9~10: reserved | 0 | O | 72 |
| P6.03 | AO lower limit | 0.0%~100.0% | 0.0% | O | 73 |
| P6.04 | AO lower limit corresponding output | 0.00V ~10.00V | 0.00V | O | 74 |
| P6.05 | AO upper limit | 0.0%~100.0% | 100.0% | O | 75 |

List of Function Parameters

| Function Code | Name | Description | Factory Setting | Modify | Serial No. |
|------------------------------------|--|---|-----------------|--------|------------|
| P6.06 | AO upper limit corresponding output | 0.00V ~10.00V | 10.00V | ○ | 76 |
| P7 Group: Display Interface | | | | | |
| P7.00 | User password | 0~65535 | 0 | ○ | 77 |
| P7.01 | LCD language selection | 0: Chinese 1: English | 0 | ○ | 78 |
| P7.02 | Parameter copy | 0: Invalid 1: Upload from inverter 2: Download to inverter | 0 | ⊙ | 79 |
| P7.03 | QUICK/JOG function selection | 0: Jog 1: FDW/REV switching 2: Clear UP/DOWN setting | 0 | ⊙ | 80 |
| P7.04 | STOP/RST function option | 0: Valid when keypad control (P0.01=0) 1: Valid when keypad or terminal control (P0.01=0 or 1) 2: Valid when keypad or communication control (P0.01=0 or 2) 3: Always valid | 0 | ○ | 81 |
| P7.05 | Keypad display selection | 0: Preferential to external keypad 1: Both display, only external key valid. 2: Both display, only local key valid. 3: Both display and key valid. | 0 | ○ | 82 |
| P7.06 | Running status display selection | 0~0X7FFF BIT0: Output frequency BIT1: Reference frequency BIT2: DC bus voltage BIT3: Output voltage BIT4: Output current BIT5: Rotation speed BIT6: Output power BIT7: Output torque BIT8: PID preset BIT9: PID feedback BIT10: Input terminal status BIT11: Output terminal status BIT12: AI1 BIT13: AI2 BIT14: Step No. of multi-step BIT15: Reserved | 0XFF | ○ | 83 |

List of Function Parameters

| Function Code | Name | Description | Factory Setting | Modify | Serial No. |
|---------------|-------------------------------|--|-----------------|--------|------------|
| P7.07 | Stop status display selection | 0~0X1FF BIT0: Reference frequency BIT1: DC bus voltage BIT2: Input terminal status BIT3: Output terminal status BIT4: PID preset BIT5: PID feedback BIT6: AI1 BIT7: AI2 BIT8: Step No. of multi-step BIT9~15: Reserved | 0xFF | ○ | 84 |
| P7.08 | Rectifier module temperature | 0~100.0℃ | | ● | 85 |
| P7.09 | IGBT module temperature | 0~100.0℃ | | ● | 86 |
| P7.10 | Software version | | | ● | 87 |
| P7.11 | Accumulated running time | 0~65535h | | ● | 88 |
| P7.12 | Third latest fault type | 0: Not fault 1: IGBT Ph-U fault(OUT1) 2: IGBT Ph-V fault(OUT2) 3: IGBT Ph-W fault(OUT3) 4: Over-current when acceleration(OC1) 5: Over-current when deceleration(OC2) 6: Over-current when constant speed running (OC3) | | ● | 89 |
| P7.13 | Second latest fault type | 7: Over-voltage when acceleration(OV1) 8: Over-voltage when deceleration(OV2) 9: Over-voltage when constant speed running(OV3) 10: DC bus Under-voltage(UV) 11: Motor overload (OL1) 12: Inverter overload (OL2) 13: Input phase failure (SPI) 14: Output phase failure (SPO) 15: Rectify overheat (OH1) 16: IGBT overheat (OH2) 17: External fault (EF) | | ● | 90 |

List of Function Parameters

| Function Code | Name | Description | Factory Setting | Modify | Serial No. | | | | | | | | |
|------------------------------------|---|---|-----------------|--------|------------|------|----|----|----|----|--|---|----|
| P7.14 | Current fault type | 18: Communication fault (CE) 19: Current detection fault (ITE) 20: Autotuning fault (TE) 21: EEPROM fault (EEP) 22: PID feedback fault (PIDE) 23: Brake unit fault (BCE) 24: Reserved | | • | 91 | | | | | | | | |
| P7.15 | Output frequency at current fault | Output frequency at current fault. | | • | 92 | | | | | | | | |
| P7.16 | Output current at current fault | Output current at current fault. | | • | 93 | | | | | | | | |
| P7.17 | DC bus voltage at current fault | DC bus voltage at current fault. | | • | 94 | | | | | | | | |
| P7.18 | Input terminal status at current fault | <table border="1" style="display: inline-table; border-collapse: collapse;"> <tr> <td style="padding: 2px;">BIT3</td> <td style="padding: 2px;">BIT2</td> <td style="padding: 2px;">BIT1</td> <td style="padding: 2px;">BIT0</td> </tr> <tr> <td style="padding: 2px;">S4</td> <td style="padding: 2px;">S3</td> <td style="padding: 2px;">S2</td> <td style="padding: 2px;">S1</td> </tr> </table> | BIT3 | BIT2 | BIT1 | BIT0 | S4 | S3 | S2 | S1 | | • | 95 |
| BIT3 | BIT2 | BIT1 | BIT0 | | | | | | | | | | |
| S4 | S3 | S2 | S1 | | | | | | | | | | |
| P7.19 | Output terminal status at current fault | <table border="1" style="display: inline-table; border-collapse: collapse;"> <tr> <td style="padding: 2px;">BIT3</td> <td style="padding: 2px;">BIT2</td> <td style="padding: 2px;">BIT1</td> <td style="padding: 2px;">BIT0</td> </tr> <tr> <td colspan="2" style="padding: 2px;">R0</td> <td colspan="2" style="padding: 2px;">Y</td> </tr> </table> | BIT3 | BIT2 | BIT1 | BIT0 | R0 | | Y | | | • | 96 |
| BIT3 | BIT2 | BIT1 | BIT0 | | | | | | | | | | |
| R0 | | Y | | | | | | | | | | | |
| P8 Group: Enhanced Function | | | | | | | | | | | | | |
| P8.00 | Acceleration time 1 | 0.1~3600.0s | Depend on model | O | 97 | | | | | | | | |
| P8.01 | Deceleration time 1 | 0.1~3600.0s | Depend on model | O | 98 | | | | | | | | |
| P8.02 | Jog reference | 0.00~P0.04 | 5.00Hz | O | 99 | | | | | | | | |
| P8.03 | Jog acceleration time | 0.1~3600.0s | Depend on model | O | 100 | | | | | | | | |
| P8.04 | Jog deceleration time | 0.1~3600.0s | Depend on model | O | 101 | | | | | | | | |
| P8.05 | Skip frequency | 0.00~P0.04 | 0.00Hz | O | 102 | | | | | | | | |
| P8.06 | Skip frequency bandwidth | 0.00~P0.04 | 0.00Hz | o | 103 | | | | | | | | |
| P8.07 | Traverse amplitude | 0.0~100.0% | 0.0% | O | 104 | | | | | | | | |

List of Function Parameters

| Function Code | Name | Description | Factory Setting | Modify | Serial No. |
|------------------------------|----------------------------------|--|-----------------|-----------------------|------------|
| P8.08 | Jitter frequency | 0.0~50.0% | 0.0% | <input type="radio"/> | 105 |
| P8.09 | Rise time of traverse | 0.1~3600.0s | 5.0s | <input type="radio"/> | 106 |
| P8.10 | Fall time of traverse | 0.1~3600.0s | 5.0s | <input type="radio"/> | 107 |
| P8.11 | Auto reset times | 0~3 | 0 | <input type="radio"/> | 108 |
| P8.12 | Reset interval | 0.1~100.0s | 1.0s | <input type="radio"/> | 109 |
| P8.13 | FDT level | 0.00~ P0.04 | 50.00Hz | <input type="radio"/> | 110 |
| P8.14 | FDT lag | 0.0~100.0% | 5.0% | <input type="radio"/> | 111 |
| P8.15 | Frequency arrive detecting range | 0.0~100.0% (maximum frequency) | 0.0% | <input type="radio"/> | 112 |
| P8.16 | Brake threshold voltage | 115.0~140.0% | Depend on model | <input type="radio"/> | 113 |
| P8.17 | Coefficient of rotation speed | 0.1~999.9% | 100.0% | <input type="radio"/> | 114 |
| P9 Group: PID Control | | | | | |
| P9.00 | PID preset source selection | 0: Keypad 1: AI1 2: AI2 3: Communication 4: Multi-step | 0 | <input type="radio"/> | 115 |
| P9.01 | Keypad PID preset | 0.0%~100.0% | 0.0% | <input type="radio"/> | 116 |
| P9.02 | PID feedback source selection | 0: AI1 1: AI2 2: AI1+AI2 3: Communication | 0 | <input type="radio"/> | 117 |
| P9.03 | PID output characteristics | 0: Positive 1: Negative | 0 | <input type="radio"/> | 118 |
| P9.04 | Proportional gain (Kp) | 0.00~100.00 | 1.00 | <input type="radio"/> | 119 |
| P9.05 | Integral time (Ti) | 0.01~10.00s | 0.10s | <input type="radio"/> | 120 |
| P9.06 | Differential time (Td) | 0.00~10.00s | 0.00s | <input type="radio"/> | 121 |

List of Function Parameters

| Function Code | Name | Description | Factory Setting | Modify | Serial No. |
|---|---|---|------------------|--------|------------|
| P9.07 | Sampling cycle (T) | 0.01~100.00s | 0.10s | ○ | 122 |
| P9.08 | Bias limit | 0.0~100.0% | 0.0% | ○ | 123 |
| P9.09 | Feedback lost detecting value | 0.0~100.0% | 0.0% | ○ | 124 |
| P9.10 | Feedback lost detecting time | 0.0~3600.0s | 1.0s | ○ | 125 |
| PA Group: Multi-step Speed Control | | | | | |
| PA.00 | Multi-step speed 0 | -100.0~100.0% | 0.0% | ○ | 126 |
| PA.01 | Multi-step speed 1 | -100.0~100.0% | 0.0% | ○ | 127 |
| PA.02 | Multi-step speed 2 | -100.0~100.0% | 0.0% | ○ | 128 |
| PA.03 | Multi-step speed 3 | -100.0~100.0% | 0.0% | ○ | 129 |
| PA.04 | Multi-step speed 4 | -100.0~100.0% | 0.0% | ○ | 130 |
| PA.05 | Multi-step speed 5 | -100.0~100.0% | 0.0% | ○ | 131 |
| PA.06 | Multi-step speed 6 | -100.0~100.0% | 0.0% | ○ | 132 |
| PA.07 | Multi-step speed 7 | -100.0~100.0% | 0.0% | ○ | 133 |
| PB Group: Protection Function | | | | | |
| PB.00 | Motor overload protection | 0: Disabled 1: Normal motor 2: Variable frequency motor | 2 | ⊗ | 134 |
| PB.01 | Motor overload protection current | 20.0%~120.0% | 100.0% | ○ | 135 |
| PB.02 | Threshold of trip-free | 70.0~110.0% | 80.0% | ○ | 136 |
| PB.03 | Decrease rate of trip-free | 0.00Hz~P0.04 | 0.00Hz | ○ | 137 |
| PB.04 | Over-voltage stall protection | 0: Disabled 1: Enabled | 0 | ○ | 138 |
| PB.05 | Over-voltage stall protection point | 110~150% | Depend on model | ○ | 139 |
| PB.06 | Auto current limiting threshold | 50~200% | G:160% P:120% | ○ | 140 |
| PB.07 | Frequency decrease rate when current limiting | 0.00~100.00Hz/s | 10.00 Hz/s | ○ | 141 |

List of Function Parameters

| Function Code | Name | Description | Factory Setting | Modify | Serial No. |
|---------------------------------------|---------------------|---|-----------------|--------|------------|
| PC Group: Serial Communication | | | | | |
| PC.00 | Local address | 0~247 | 1 | O | 142 |
| PC.01 | Baud rate selection | 0: 1200BPS 1: 2400BPS 2: 4800BPS 3: 9600BPS 4: 19200BPS 5: 38400BPS | 3 | O | 143 |
| PC.02 | Data format | 0: RTU, 1 start bit, 8 data bits, no parity check, 1 stop bit. 1: RTU, 1 start bit, 8 data bits, even parity check, 1 stop bit. 2: RTU, 1 start bit, 8 data bits, odd parity check, 1 stop bit. 3: RTU, 1 start bit, 8 data bits, no parity check, 2 stop bits. 4: RTU, 1 start bit, 8 data bits, even parity check, 2 stop bits. 5: RTU, 1 start bit, 8 data bits, odd parity check, 2 stop bits. 6: ASCII, 1 start bit, 7 data bits, no parity check, 1 stop bit. 7: ASCII, 1 start bit, 7 data bits, even parity check, 1 stop bit. 8: ASCII, 1 start bit, 7 data bits, odd parity check, 1 stop bit. 9: ASCII, 1 start bit, 7 data bits, no parity check, 2 stop bits. 10: ASCII, 1 start bit, 7 data bits, even parity check, 2 stop bits. 11: ASCII, 1 start bit, 7 data bits, odd parity check, 2 stop bits. 12: ASCII, 1 start bit, 8 data bits, no parity check, 1 stop bit. 13: ASCII, 1 start bit, 8 data bits, even parity check, 1 stop bit. 14: ASCII, 1 start bit, 8 data bits, odd parity check, 1 stop bit. 15: ASCII, 1 start bit, 8 data bits, no parity check, 2 stop bits. 16: ASCII, 1 start bit, 8 data bits, even parity check, 2 stop bits. 17: ASCII, 1 start bit, 8 data bits, odd parity check, 2 stop bits. | 0 | O | 144 |

List of Function Parameters

| Function Code | Name | Description | Factory Setting | Modify | Serial No. |
|---|---|--|-----------------|--------|------------|
| PC.03 | Communication delay time | 0~200ms | 5 | O | 145 |
| PC.04 | Communication timeout delay | 0.0: Disabled 0.1~100.0s | 0.0s | O | 146 |
| PC.05 | Communication error action | 0: Alarm and coast to stop 1: No alarm and continue to run 2: No alarm but stop according to P1.05 (if P0.01=2) 3: No alarm but stop according to P1.05 | 1 | O | 147 |
| PC.06 | Response action | Unit's place of LED 0: Response to writing 1: No response to writing Ten's place of LED 0: Reference not saved when power off 1: Reference saved when power off | 0 | O | 148 |
| PD Group: Supplementary Function | | | | | |
| PD.00 | Low-frequency threshold of restraining oscillation | 0~500 | 5 | O | 149 |
| PD.01 | High-frequency threshold of restraining oscillation | 0~500 | 100 | O | 150 |
| PD.02 | Amplitude of restraining oscillation | 0~10000 | 5000 | O | 151 |
| PD.03 | Boundary of restraining oscillation | 0.0~P0.04 | 12.5Hz | O | 152 |
| PD.04 | Restraining oscillation | 0: Enabled 1: Disabled | 0 | O | 153 |
| PD.05 | PWM mode | 0: PWM mode 1 1: PWM mode 2 2: PWM mode 3 | 0 | ⊗ | 154 |
| PD.06 | Torque setting source | 0: Keypad 1: AI1 2: AI2 3: AI1+AI2 4: Multi-step setting 5: Communication | 0 | O | 155 |

List of Function Parameters

| Function Code | Name | Description | Factory Setting | Modify | Serial No. |
|----------------------------------|---------------------------------|--|-----------------|--------|------------|
| PD.07 | Keypad torque setting | -100.0%~100.0% | 0 | ○ | 156 |
| PD.08 | Upper frequency limit selection | 0: Keypad (P0.05) 1: AI1 2: AI2 3: Multi-step setting 4: Communication | 0 | ○ | 157 |
| PD.09 | Auto current limiting selection | 0: Enabled 1: Disabled when constant speed | 0 | ○ | 158 |
| PE Group: Factory Setting | | | | | |
| PE.00 | Factory password | 0~65535 | ***** | ● | 159 |

Special parameter for CHE150 series high speed inverter is as follow:

| Function Code | Name | Description | Factory Setting | Modify |
|---------------------------------|----------------------------|---|-----------------|--------|
| P0 Group: Basic Function | | | | |
| P0.04 | Maximum frequency | 10.00~1500.0Hz | 1000.0Hz | ⊗ |
| P0.05 | Upper frequency limit | P0.06~ P0.04 | 1000.0Hz | ○ |
| P0.07 | Keypad reference frequency | 0.00 Hz ~ P0.04 | 1000.0Hz | ○ |
| P4 Group: V/F Control | | | | |
| P4.00 | V/F curve selection | 0:Linear curve 1: User-defined curve 2: Torque_stepdown curve (1.3 order) 3: Torque_stepdown curve (1.7 order) 4: Torque_stepdown curve (2.0 order) | 0 | ⊗ |
| P4.03 | V/F frequency 1 | 0.0Hz ~ P4.05 | 100.0Hz | ○ |
| P4.04 | V/F voltage 1 | 0.0% ~ 100.0% (motor rated voltage) | 10.0% | ⊗ |
| P4.05 | V/F frequency 2 | P4.03 ~ P4.07 | 600.0Hz | ○ |
| P4.06 | V/F voltage 2 | 0.0% ~ 100.0% (motor rated voltage) | 60.0% | ⊗ |

List of Function Parameters

| Function Code | Name | Description | Factory Setting | Modify |
|---------------|------------------------------|---------------------------------------|-----------------|--------|
| P4.07 | V/F frequency 3 | P4.05 ~ P2.02 (motor rated frequency) | 1000.0Hz | ○ |
| P4.08 | V/F voltage 3 | 0.0% ~ 100.0% (motor rated voltage) | 100.0% | ⊙ |
| P4.09 | V/F Slip compensation limit | 0.00~200.0% | 0.0% | ○ |
| P4.10 | Auto energy saving selection | 0: Disabled 1: Enabled | 0 | ⊙ |

Parameters display on LCD keypad

| Function Code | Name | LCD Display |
|---------------|---------------------------------|-----------------|
| P0.00 | Control mode selection | CONTROL MODE |
| P0.01 | Run command source | RUN COMMAND |
| P0.02 | UP/DOWN setting | UP/DOWN SETTING |
| P0.03 | Frequency A command source | FREQ SOURCE A |
| P0.04 | Maximum frequency | MAX FREQ |
| P0.05 | Upper frequency limit | UP FREQ LIMIT |
| P0.06 | Lower frequency limit | LOW FREQ LIMIT |
| P0.07 | Keypad reference frequency | KEYPAD REF FREQ |
| P0.08 | Acceleration time 0 | ACC TIME 0 |
| P0.09 | Deceleration time 0 | DEC TIME 0 |
| P0.10 | Running direction selection | RUN DIRECTION |
| P0.11 | Carrier frequency | CARRIER FREQ |
| P0.12 | Motor parameters autotuning | AUTOTUNING |
| P0.13 | Restore parameters | RESTORE PARA |
| P0.14 | AVR function | AVR |
| P1.00 | Start Mode | START MODE |
| P1.01 | Starting frequency | START FREQ |
| P1.02 | Hold time of starting frequency | HOLD TIME |
| P1.03 | DC Braking current before start | START BRAK CURR |
| P1.04 | DC Braking time before start | START BRAK TIME |

List of Function Parameters

| Function Code | Name | LCD Display |
|---------------|----------------------------------|------------------|
| P1.05 | Stop mode | STOP MODE |
| P1.06 | Starting frequency of DC braking | STOP BRAK FREQ |
| P1.07 | Waiting time before DC braking | STOP BRAK DELAY |
| P1.08 | DC braking current | STOP BRAK CURR |
| P1.09 | DC braking time | STOP BRAK TIME |
| P1.10 | Dead time of FWD/REV | FWD/REV DEADTIME |
| P1.11 | FWD/REV enable when power on | FWD/REV ENABLE |
| P1.12 | Reserved | RESERVED |
| P2.00 | G/P option | G/P OPTION |
| P2.01 | Motor rated power | MOTOR RATE POWER |
| P2.02 | Motor rated frequency | MOTOR RATE FREQ |
| P2.03 | Motor rated speed | MOTOR RATE SPEED |
| P2.04 | Motor rated voltage | MOTOR RATE VOLT |
| P2.05 | Motor rated current | MOTOR RATE CURR |
| P2.06 | Motor stator resistance | STATOR RESISTOR |
| P2.07 | Motor rotor resistance | ROTOR RESISTOR |
| P2.08 | Motor leakage inductance | LEAK INDUCTOR |
| P2.09 | Motor mutual inductance | MUTUAL INDUCTOR |
| P2.10 | Current without load | NO LOAD CURR |
| P3.00 | ASR proportional gain Kp1 | ASR Kp1 |
| P3.01 | ASR integral time Ki1 | ASR Ki1 |
| P3.02 | ASR switching point 1 | ASR SWITCHPOINT1 |
| P3.03 | ASR proportional gain Kp2 | ASR Kp2 |
| P3.04 | ASR integral time Ki2 | ASR Ki2 |
| P3.05 | ASR switching point 2 | ASR SWITCHPOINT2 |
| P3.06 | Slip compensation rate of VC | VC SLIP COMP |
| P3.07 | Torque limit | TORQUE LIMIT |
| P4.00 | V/F curve selection | V/F CURVE |

| Function Code | Name | LCD Display |
|---------------|---------------------------------------|-----------------|
| P4.01 | Torque boost | TORQUE BOOST |
| P4.02 | Torque boost cut-off | BOOST CUT-OFF |
| P4.03 | V/F Slip compensation limit | SLIP COMP LIMIT |
| P4.04 | Auto energy saving selection | ENERGY SAVING |
| P4.05 | Reserved | RESERVED |
| P5.00 | S1 terminal function | S1 FUNCTION |
| P5.01 | S2 terminal function | S2 FUNCTION |
| P5.02 | S3 terminal function | S3 FUNCTION |
| P5.03 | S4 terminal function | S4 FUNCTION |
| P5.04 | ON/OFF filter times | Sx FILTER TIMES |
| P5.05 | FWD/REV control mode | FWD/REV CONTROL |
| P5.06 | UP/DOWN setting change rate | UP/DOWN RATE |
| P5.07 | AI1 lower limit | AI1 LOW LIMIT |
| P5.08 | AI1 lower limit corresponding setting | AI1 LOW SETTING |
| P5.09 | AI1 upper limit | AI1 UP LIMIT |
| P5.10 | AI1 upper limit corresponding setting | AI1 UP SETTING |
| P5.11 | AI1 filter time constant | AI1 FILTER TIME |
| P5.12 | AI2 lower limit | AI2 LOW LIMIT |
| P5.13 | AI2 lower limit corresponding setting | AI2 LOW SETTING |
| P5.14 | AI2 upper limit | AI2 UP LIMIT |
| P5.15 | AI2 upper limit corresponding setting | AI2 UP SETTING |
| P5.16 | AI2 filter time constant | AI2 FILTER TIME |
| P6.00 | Y output selection | Y SELECTION |
| P6.01 | Relay output selection | RO SELECTION |
| P6.02 | AO selection | AO SELECTION |
| P6.03 | AO lower limit | AO LOW LIMIT |
| P6.04 | AO lower limit corresponding output | AO LOW OUTPUT |
| P6.05 | AO upper limit | AO UP LIMIT |
| P6.06 | AO upper limit corresponding output | AO UP OUTPUT |

List of Function Parameters

| Function Code | Name | LCD Display |
|---------------|---|------------------|
| P7.00 | User password | USER PASSWORD |
| P7.01 | LCD language selection | LANGUAGE SELECT |
| P7.02 | Parameter copy | PARA COPY |
| P7.03 | QUICK/JOG function selection | QUICK/JOG FUNC |
| P7.04 | STOP/RST function option | STOP/RST FUNC |
| P7.05 | Keypad display selection | KEYPAD DISPLAY |
| P7.06 | Running status display selection | RUNNING DISPLAY |
| P7.07 | Stop status display selection | STOP DISPLAY |
| P7.08 | Rectifier module temperature | RECTIFIER TEMP |
| P7.09 | IGBT module temperature | IGBT TEMP |
| P7.10 | Software version | SOFTWARE VERSION |
| P7.11 | Accumulated running time | TOTAL RUN TIME |
| P7.12 | Third latest fault type | 3rd LATEST FAULT |
| P7.13 | Second latest fault type | 2nd LATEST FAULT |
| P7.14 | Current fault type | CURRENT FAULT |
| P7.15 | Output frequency at current fault | FAULT FREQ |
| P7.16 | Output current at current fault | FAULT CURR |
| P7.17 | DC bus voltage at current fault | FAULT DC VOLT |
| P7.18 | Input terminal status at current fault | FAULT Sx STATUS |
| P7.19 | Output terminal status at current fault | FAULT DO STATUS |
| P8.00 | Acceleration time 1 | ACC TIME 1 |
| P8.01 | Deceleration time 1 | DEC TIME 1 |
| P8.02 | Jog reference | JOG REF |
| P8.03 | Jog acceleration time | JOG ACC TIME |
| P8.04 | Jog deceleration time | JOG DEC TIME |
| P8.05 | Skip frequency | SKIP FREQ |
| P8.06 | Skip frequency bandwidth | SKIP FREQ RANGE |
| P8.07 | Traverse amplitude | TRAV AMPLITUDE |
| P8.08 | Jitter frequency | JITTER FREQ |

| Function Code | Name | LCD Display |
|---------------|----------------------------------|-------------------|
| P8.09 | Rise time of traverse | TRAV RISE TIME |
| P8.10 | Fall time of traverse | TRAV FALL TIME |
| P8.11 | Auto reset times | AUTO RESET TIMES |
| P8.12 | Reset interval | RESET INTERVAL |
| P8.13 | FDT level | FDT LEVEL |
| P8.14 | FDT lag | FDT LAG |
| P8.15 | Frequency arrive detecting range | FAR RANGE |
| P8.16 | Brake threshold voltage | BRAK VOLT |
| P8.17 | Coefficient of rotation speed | SPEED RATIO |
| P9.00 | PID preset source selection | PID PRESET |
| P9.01 | Keypad PID preset | KEYPAD PID SET |
| P9.02 | PID feedback source selection | PID FEEDBACK |
| P9.03 | PID output characteristics | PID OUTPUT |
| P9.04 | Proportional gain (Kp) | PROPORTION GAIN |
| P9.05 | Integral time (Ti) | INTEGRAL TIME |
| P9.06 | Differential time (Td) | DIFFERENTIAL TIME |
| P9.07 | Sampling cycle (T) | SAMPLING CYGLE |
| P9.08 | Bias limit | BIAS LIMIT |
| P9.09 | Feedback lost detecting value | FEEDBACK LOST |
| P9.10 | Feedback lost detecting time | FEEDBACK LOST(t) |
| PA.00 | Multi-step speed 0 | MULTI-SPEED 0 |
| PA.01 | Multi-step speed 1 | MULTI-SPEED 1 |
| PA.02 | Multi-step speed 2 | MULTI-SPEED 2 |
| PA.03 | Multi-step speed 3 | MULTI-SPEED 3 |
| PA.04 | Multi-step speed 4 | MULTI-SPEED 4 |
| PA.05 | Multi-step speed 5 | MULTI-SPEED 5 |
| PA.06 | Multi-step speed 6 | MULTI-SPEED 6 |
| PA.07 | Multi-step speed 7 | MULTI-SPEED 7 |

List of Function Parameters

| Function Code | Name | LCD Display |
|---------------|---|------------------|
| PB.00 | Motor overload protection | MOTOR OVERLOAD |
| PB.01 | Motor overload protection current | OVERLOAD CURR |
| PB.02 | Threshold of trip-free | TRIPFREE POINT |
| PB.03 | Decrease rate of trip-free | TRIPFREE DECRATE |
| PB.04 | Over-voltage stall protection | OV STALL PROTECT |
| PB.05 | Over-voltage stall protection point | OV PROTECT POINT |
| PB.06 | Auto current limiting threshold | CURR LIMIT POINT |
| PB.07 | Frequency decrease rate when current limiting | FREQ DEC RATE |
| PC.00 | Local address | LOCAL ADDRESS |
| PC.01 | Baud rate selection | BAUD RATE |
| PC.02 | Data format | DATA FORMAT |
| PC.03 | Communication delay time | COM DELAY TIME |
| PC.04 | Communication timeout delay | COM TIMEOUT |
| PC.05 | Communication error action | COM ERR ACTION |
| PC.06 | Response action | RESPONSE ACTION |
| PD.00 | Low-frequency threshold of restraining oscillation | RES OSC L POINT |
| PD.01 | High-frequency threshold of restraining oscillation | RES OSC H POINT |
| PD.02 | Amplitude of restraining oscillation | RES OSC AMP |
| PD.03 | Boundary of restraining oscillation | RES OSC BOUND |
| PD.04 | Restraining oscillation | RES OSC ENABLE |
| PD.05 | PWM mode | PWM MODE |
| PD.06 | Torque setting source | TORQ SOURCE |
| PD.07 | Keypad torque setting | KEYPAD TORQ SET |
| PD.08 | Upper frequency limit selection | UP FREQ SOURCE |
| PD.09 | Auto current limiting selection | CURR LIMIT SEL |
| PE.00 | Factory password | FACTORY PASSWORD |

10. COMMUNICATION PROTOCOL

10.1 Interfaces

RS485: asynchronous, half-duplex.

Default: 8-E-1, 19200bps. See Group PC parameter settings.

10.2 Communication Modes

- 1) The protocol is Modbus protocol. Besides the common register Read/Write operation, it is supplemented with commands of parameters management.
- 2) The drive is a slave in the network. It communicates in 'point to point' master-slave mode. It will not respond to the command sent by the master via broadcast address.
3. In the case of multi-drive communication or long-distance transmission, connecting a 100~120Ω resistor in parallel with the master signal line will help to enhance the immunity to interference.

10.3 Protocol Format

Modbus protocol supports both RTU and ASCII mode. The frame format is illustrated as follows:

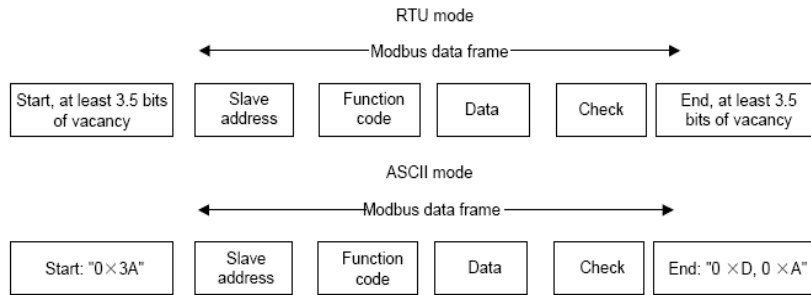

Modbus adopts "Big Endian" representation for data frame. This means that when a numerical quantity larger than a byte is transmitted, the most significant byte is sent first.

RTU mode

In RTU mode, the Modbus minimum idle time between frames should be no less than 3.5 bytes. The checksum adopts CRC-16 method. All data except checksum itself sent will be counted into the calculation. Please refer to section: CRC Check for more information.

Note that at least 3.5 bytes of Modbus idle time should be kept and the start and end idle time need not be summed up to it.

The table below shows the data frame of reading parameter 002 from slave node address 1.

| Node addr. | Command | Data addr. | | Read No. | | CRC | |
|------------|---------|------------|------|----------|------|------|------|
| 0x01 | 0x03 | 0x00 | 0x02 | 0x00 | 0x01 | 0x25 | 0xCA |

The table below shows the reply frame from slave node address 1

| Node addr. | Command | Bytes No. | Data | | CRC | |
|------------|---------|-----------|------|------|------|------|
| 0x01 | 0x03 | 0x02 | 0x00 | 0x00 | 0xB8 | 0x44 |

ASCII mode

In ASCII mode, the frame head is "0x3A", and default frame tail is "0x0D" or "0x0A". The frame tail can also be configured by users. Except frame head and tail, other bytes will be sent as two ASCII characters, first sending higher nibble and then lower nibble. The data have 7/8 bits. "A"~"F" corresponds to the ASCII code of respective capital letter. LRC check is used. LRC is calculated by adding all the successive bytes of the message except the head and tail, discarding any carriers, and then two's complementing the result.

Example of Modbus data frame in ASCII mode:

The command frame of writing 0x0003 into address "0x1000" of slave node address 1 is shown in the table below:

LRC checksum = the complement of (01+06+10+00+0x00+0x03) = 0xE5

| | Frame head | Node addr. | | Command | | Data addr. | | | |
|---------------|------------|------------|----|---------|----|------------|----|----|----|
| Code | | 0 | 1 | 0 | 6 | 1 | 0 | 0 | 0 |
| ASCII | 3A | 30 | 31 | 30 | 36 | 31 | 30 | 30 | 30 |
| Data to write | | | | LRC | | Frame tail | | | |
| 0 | 0 | 0 | 3 | E | 5 | CR | | LF | |
| 30 | 30 | 30 | 33 | 45 | 35 | 0D | | 0A | |

10.4 Protocol function

Different respond delay can be set through drive's parameters to adapt to different needs. For RTU mode, the respond delay should be no less than 3.5 bytes interval, and for ASCII mode, no less than 1ms.

The main function of Modbus is to read and write parameters. The Modbus protocol supports the following commands:

| | |
|------|--|
| 0x03 | Read inverter's function parameter and status parameters |
| 0x06 | Write single function parameter or command parameter to inverter |

All drive's function parameters, control and status parameters are mapped to Modbus R/W data address.

The data addresses of each function parameters please refer the sixth column of chapter 9.

The data address of control and status parameters please refer to the following table.

| Parameter Description | Address | Meaning of value | R/W Feature |
|-----------------------|-------------------------------|---|-------------|
| Control command | 1000H | 0001H: Forward | W/R |
| | | 0002H: Reverse | |
| | | 0003H: JOG forward | |
| | | 0004H: JOG reverse | |
| | | 0005H: Stop | |
| | | 0006H: Coast to stop | |
| | | 0007H: Reset fault | |
| | | 0008H: JOG stop | |
| Inverter status | 1001H | 0001H: Forward running | R |
| | | 0002H: Reverse running | |
| | | 0003H: Standby | |
| | | 0004H: Fault | |
| Communication setting | 2000H | Communication Setting Range (-10000~10000) Note: the communication setting is the percentage of the relative value (-100.00%~100.00%). If it is set as frequency source, the value is the percentage of the maximum frequency (P0.04). If it is set as PID (preset value or feedback value), the value is the percentage of the PID. | W/R |
| Status parameters | 3000H | Output frequency | R |
| | 3001H | Reference frequency | R |
| | 3002H | DC Bus voltage | R |
| | 3003H | Output voltage | R |
| | 3004H | Output current | R |
| | 3005H | Rotation speed | R |
| | 3006H | Output power | R |
| | 3007H | Output torque | R |
| | 3008H | PID preset value | R |
| | 3009H | PID feedback value | R |
| | 300AH | Input terminal status | R |
| | 300BH | Output terminal status. | R |
| | 300CH | Input of AI1 | R |
| | 300DH | Input of AI2 | R |
| | 300EH | Reserved | R |
| | 300FH | Reserved | R |
| | 3010H | HDI frequency | R |
| | 3011H | Reserved | R |
| 3012H | Step No. of PLC or multi-step | R | |

| | | | |
|---|-------|--|---|
| | 3013H | Length value | R |
| | 3014H | External counter input | R |
| | 3015H | Reserved | R |
| | 3016H | Device code | R |
| Fault info address | 5000H | This address stores the fault type of inverter. The meaning of each value is same as P7.15. | R |
| ModBus communication fault info address | 5001H | 0000H: No fault 0001H: Wrong password 0002H: Command code error 0003H: CRC error 0004H: Invalid address 0005H: Invalid data 0006H: Parameter change invalid 0007H: System locked 0008H: Busy (EEPROM is storing) | R |

The above shows the format of the frame. Now we will introduce the Modbus command and data structure in details, which is called protocol data unit for simplicity. Also MSB stands for the most significant byte and LSB stands for the least significant byte for the same reason. The description below is data format in RTU mode. The length of data unit in ASCII mode should be doubled.

Protocol data unit format of reading parameters:

Request format:

| Protocol data unit | Data length(bytes) | Range |
|--------------------|--------------------|---------------|
| Command | 1 | 0x03 |
| Data Address | 2 | 0~0xFFFF |
| Read number | 2 | 0x0001~0x0010 |

Reply format (success):

| Protocol data unit | Data length(bytes) | Range |
|----------------------|--------------------|----------------|
| Command | 1 | 0x03 |
| Returned byte number | 2 | 2* Read number |
| Content | 2* Read number | |

If the command is reading the type of inverter (data address 0x3016), the content value in reply message is the device code:

The high 8 bit of device code is the type of the inverter, and the low 8 bit of device code is the sub type of inverter.

For details, please refer to the following table:

| High byte | Meaning | Low byte | Meaning |
|-----------|---------|----------|----------------------------|
| 00 | CHV | 01 | Universal type |
| | | 02 | For water supply |
| | | 03 | Middle frequency 1500HZ |
| | | 04 | Middle frequency 3000HZ |
| 01 | CHE | 01 | Universal type |
| | | 02 | Middle frequency 1500HZ |
| 02 | CHF | 01 | Universal type |

If the operation fails, the inverter will reply a message formed by failure command and error code. The failure command is (Command+0x80). The error code indicates the reason of the error; see the table below.

| Value | Name | Mean |
|-------|-----------------------|--|
| 01H | Illegal command | The command from master can not be executed. The reason maybe: 1. This command is only for new version and this version can not realize. 2. Slave is in fault status and can not execute it. |
| 02H | Illegal data address. | Some of the operation addresses are invalid or not allowed to access. |
| 03H | Illegal value | When there are invalid data in the message framed received by slave. Note: This error code does not indicate the data value to write exceed the range, but indicate the message frame is a illegal frame. |
| 06H | Slave busy | Inverter is busy(EEPROM is storing) |
| 10H | Password error | The password written to the password check address is not same as the password set by P7.00. |
| 11H | Check error | The CRC (RTU mode) or LRC (ASCII mode) check not passed. |
| 12H | Written not allowed. | It only happen in write command, the reason maybe: 1. the data to write exceed the range of according parameter 2. The parameter should not be modified now. 3. The terminal has already been used. |
| 13H | System locked | When password protection take effect and user does not unlock it, write/read the function parameter will return this error. |

Protocol data unit format of writing single parameter:

Request format:

| Protocol data unit | Data length(bytes) | Range |
|--------------------|--------------------|----------|
| Command | 1 | 0x06 |
| Data Address | 2 | 0~0xFFFF |
| Write Content | 2 | 0~0xFFFF |

Reply format (success):

| Protocol data unit | Data length(bytes) | Range |
|--------------------|--------------------|----------|
| Command | 1 | 0x06 |
| Data Address | 2 | 0~0xFFFF |
| Write Content | 2 | 0~0xFFFF |

If the operation fails, the inverter will reply a message formed by failure command and error code. The failure command is (Command+0x80). The error code indicates the reason of the error; see table 1.

10.5 Note:

1. Between frames, the span should not less than 3.5 bytes interval, otherwise, the message will be discarded.
2. Be cautious to modify the parameters of PC group through communication, otherwise may cause the communication interrupted.
3. In the same frame, if the span between two .near bytes more than 1.5 bytes interval, the behind bytes will be assumed as the start of next message so that communication will failure.

10.6 CRC Check

For higher speed, CRC-16 uses tables. The following are C language source code for CRC-16.

```

unsigned int crc_cal_value(unsigned char *data_value,unsigned char data_length)
{
    int i;
    unsigned int crc_value=0xffff;
    while(data_length--)
    {
        crc_value^=*data_value++;
        for(i=0;i<8;i++)
        {
            if(crc_value&0x0001)crc_value=(crc_value>>1)^0xa001;
            else crc_value=crc_value>>1;
        }
    }
    return(crc_value);
}

```

10.7 Example

1. RTU mode, read 2 data from 0004H

The request command is:

| | |
|----------------------------|--|
| START | T1-T2-T3-T4 (transmission time of 3.5 bytes) |
| Node address | 01H |
| Command | 03H |
| High byte of start address | 00H |
| Low byte of start address | 04H |
| High byte of data number | 00H |
| Low byte of data number | 02H |
| Low byte of CRC | 85H |
| High byte of CRC | CAH |
| END | T1-T2-T3-T4 (transmission time of 3.5 bytes) |

The reply is :

| | |
|----------------------|--|
| START | T1-T2-T3-T4 (transmission time of 3.5 bytes) |
| Node address | 01H |
| Command | 03H |
| Returned byte number | 04H |
| Higher byte of 0004H | 00H |
| Low byte of 0004H | 00H |
| High byte of 0005H | 00H |
| Low byte of 0005H | 00H |
| Low byte of CRC | 43H |
| High byte of CRC | 07H |
| END | T1-T2-T3-T4 (transmission time of 3.5 bytes) |

2. ASCII mode, read 2 data from 0004H:

The request command is:

| | |
|----------------------------|-----|
| START | ⋮ |
| Node address | '0' |
| | '1' |
| Command | '0' |
| | '3' |
| High byte of start address | '0' |
| | '0' |
| Low byte of start address | '0' |
| | '4' |
| High byte of data number | '0' |
| | '0' |
| Low byte of data number | '0' |
| | '2' |
| LRC CHK Hi | 'F' |
| LRC CHK Lo | '6' |
| END Lo | CR |
| END Hi | LF |

The reply is

| | |
|----------------------|-----|
| START | ⋮ |
| Node address | '0' |
| | '1' |
| Command | '0' |
| | '3' |
| Returned byte number | '0' |
| | '4' |
| Higher byte of 0004H | '0' |
| | '0' |
| Low byte of 0004H | '0' |
| | '0' |
| High byte of 0005H | '0' |
| | '0' |
| Low byte of 0005H | '0' |
| | '0' |
| LRC CHK Lo | 'F' |
| LRC CHK Hi | '8' |
| END Lo | CR |
| END Hi | LF |

3. RTU mode, write 5000(1388H) into address 0008H, slave node address 02.

The request command is:

| | |
|----------------------------|--|
| START | T1-T2-T3-T4 (transmission time of 3.5 bytes) |
| Node address | 02H |
| Command | 06H |
| High byte of data address | 00H |
| Low byte of data address | 08H |
| High byte of write content | 13H |
| Low byte of write content | 88H |
| Low byte of CRC | 05H |
| High byte of CRC | 6DH |
| END | T1-T2-T3-T4 (transmission time of 3.5 bytes) |

The reply command is:

| | |
|----------------------------|--|
| START | T1-T2-T3-T4 (transmission time of 3.5 bytes) |
| Node address | 02H |
| Command | 06H |
| High byte of data address | 00H |
| Low byte of data address | 08H |
| High byte of write content | 13H |
| Low byte of write content | 88H |
| Low byte of CRC | 05H |
| High byte of CRC | 6DH |
| END | T1-T2-T3-T4 (transmission time of 3.5 bytes) |

4. ASCII mode, write 5000(1388H) into address 0008H, slave node address 02.

The request command is:

| | |
|----------------------------|-----|
| START | ':' |
| Node address | '0' |
| | '2' |
| Command | '0' |
| | '6' |
| High byte of data address | '0' |
| | '0' |
| Low byte of data address | '0' |
| | '8' |
| High byte of write content | '1' |
| | '3' |
| Low byte of write content | '8' |
| | '8' |
| LRC CHK Hi | '5' |
| LRC CHK Lo | '5' |
| END Lo | CR |
| END Hi | LF |

The reply command is:

| | |
|----------------------------|-----|
| START | ':' |
| Node address | '0' |
| | '2' |
| Command | '0' |
| | '6' |
| High byte of data address | '0' |
| | '0' |
| Low byte of data address | '0' |
| | '8' |
| High byte of write content | '1' |
| | '3' |
| Low byte of write content | '8' |
| | '8' |
| LRC CHK Hi | '5' |
| LRC CHK Lo | '5' |
| END Lo | CR |
| END Hi | LF |