



DELTA ELECTRONICS, INC.

www.delta.com.tw/industrialautomation

ASIA

Delta Electronics, Inc.

Taoyuan1

31-1, Xingbang Road, Guishan Industrial Zone,
Taoyuan County 33370, Taiwan, R.O.C.
TEL: 886-3-362-6301 / FAX: 886-3-362-7267

Delta Electronics (Jiang Su) Ltd.

Wujiang Plant3

1688 Jiangxing East Road,
Wujiang Economy Development Zone,
Wujiang City, Jiang Su Province,
People's Republic of China (Post code: 215200)
TEL: 86-512-6340-3008 / FAX: 86-512-6340-7290

Delta Electronics (Japan), Inc.

Tokyo Office

Delta Shibadaimon Building, 2-1-14 Shibadaimon,
Minato-Ku, Tokyo, 105-0012, Japan
TEL: 81-3-5733-1111 / FAX: 81-3-5733-1211

Delta Electronics (Korea), Inc.

234-9, Duck Soo BD 7F, Nonhyun-dong,
Kangnam-ku, Seoul, Korea
Post code : 135-010
TEL: 82-2-515-5305 / FAX: 82-2-515-5302

Delta Electronics (Singapore) Pte. Ltd.

8 Kaki Bukit Road 2, #04-18 Ruby Warehouse Complex,
Singapore 417841
TEL: 65-747-5155 / FAX: 65-744-9228

Delta Energy Systems (India) Pvt. Ltd.

Plot No. 27 & 31, Sector-34, EHTP,
Gurgaon-122001 Haryana, India
TEL: 91-124-4169040 / FAX: 91-124-4036045

AMERICA

Delta Products Corporation (USA)

Raleigh Office

P.O. Box 12173, 5101 Davis Drive,
Research Triangle Park, NC 27709, U.S.A.
TEL: 1-919-767-3813 / FAX: 1-919-767-3939

EUROPE

Deltronics (The Netherlands) B.V.

Eindhoven Office

De Witbogt 15, 5652 AG Eindhoven, The Netherlands
TEL: 31-40-2592850 / FAX: 31-40-2592851

*We reserve the right to change the information in this manual without prior notice



ASDA-A & A+ Series User Manual



ASDA-A & A+ Series User Manual

Advanced AC Servo Drive for General Purpose Applications

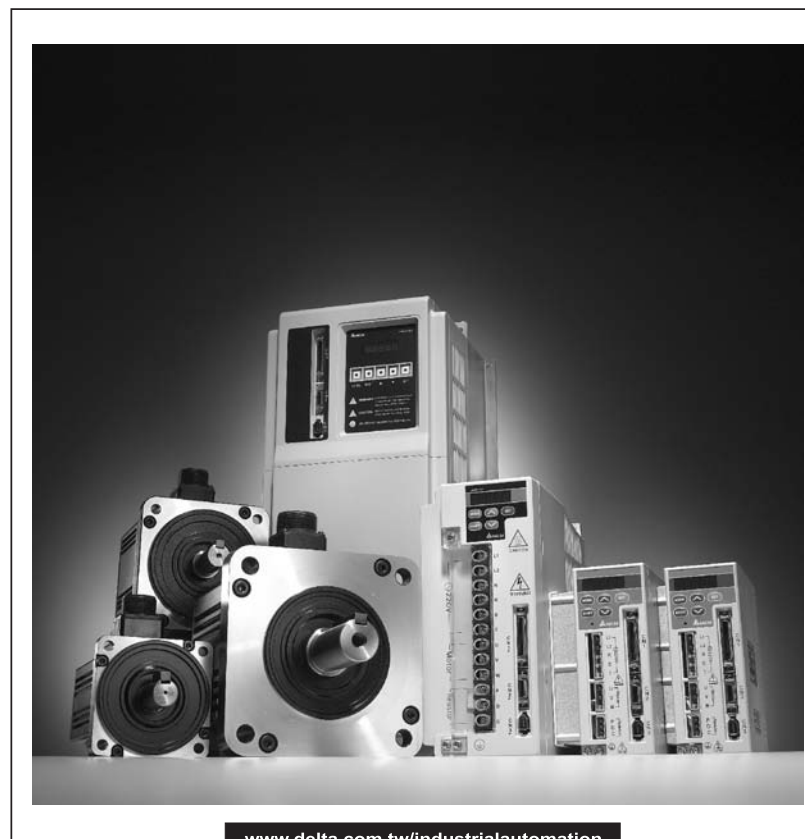

www.delta.com.tw/industrialautomation

20090423

Send Quote Requests to info@automatedpt.com
Call +1(800)985-6929 To Order or Order Online At Deltaacdrives.com

Preface

Thank you very much for purchasing DELTA's AC servo products.

This manual will be helpful in the installation, wiring, inspection, and operation of Delta AC servo drive and motor. Before using the product, please read this user manual to ensure correct use.

You should thoroughly understand all safety precautions (DANGERS, WARNINGS and STOPS) before proceeding with the installation, wiring and operation. If you do not understand please contact your local Delta sales representative. Place this user manual in a safe location for future reference.

Using This Manual

■ Contents of this manual

This manual is a user guide that provides the information on how to install, operate and maintain ASDA-A and ASDA-A+ series AC servo drives, and ASMT and ECMA series AC servo motors. The contents of this manual are including the following topics:

- Installation of AC servo drives and motors
- Configuration and wiring
- Trial run steps
- Control functions and adjusting methods of AC servo drives
- Parameter settings
- Communication protocol
- Inspection and maintenance
- Troubleshooting
- Application examples

■ Who should use this manual

This user manual is intended for the following users:

- Those who are responsible for designing.
- Those who are responsible for installing or wiring.
- Those who are responsible for operating or programming.
- Those who are responsible for maintaining or troubleshooting.

■ Important precautions

Before using the product, please read this user manual thoroughly to ensure correct use and store this manual in a safe and handy place for quick reference whenever necessary. Besides, please observe the following precautions:

- Do not use the product in a potentially explosive environment.
- Install the product in a clean and dry location free from corrosive and inflammable gases or liquids.
- Do not connect a commercial power supply to the U, V, W terminals of motor. Failure to observe this precaution will damage either the Servo motor or drive.

Preface | ASDA-A&A+ Series

- Ensure that the motor and drive are correctly connected to a ground. The grounding method must comply with the electrical standard of the country (Please refer to NFPA 70: National Electrical Code, 2005 Ed.).
- Do not disconnect the AC servo drive and motor while the power is ON.
- Do not attach, modify and remove wiring when power is applied to the AC servo drive and motor.
- Before starting the operation with a mechanical system connected, make sure the emergency stop equipment can be energized and work at any time.
- Do not touch the drive heat sink or the servo motor during operation. Otherwise, it may result in serious personnel injury.

PLEASE READ PRIOR TO INSTALLATION FOR SAFETY.

Carefully note and observe the following safety precautions when receiving, inspecting, installing, operating, maintaining and troubleshooting. The following words, DANGER, WARNING and STOP are used to mark safety precautions when using the Delta's servo product. **Failure to observe these precautions may void the warranty!**

ASDA-A and ASDA-A+ series drives are open type servo drives and must be installed in an NEMA enclosure such as a protection control panel during operation to comply with the requirements of the international safety standards. They are provided with precise feedback control and high-speed calculation function incorporating DSP (Digital Signal Processor) technology, and intended to drive three-phase permanent magnet synchronous motors (PMSM) to achieve precise positioning by means of accurate current output generated by IGBT (Insulated Gate Bipolar Transistor).

ASDA-A and ASDA-A+ series drives can be used in industrial applications and for installation in an end-use enclosure that do not exceed the specifications defined in the ASDA-A and ASDA-A+ series user manual (Drives, cables and motors are for use in a suitable enclosure with a minimum of a UL50 type 1 or NEMA 250 Type 1 rating).

The words, DANGER, WARNING and STOP, have the following meaning:



Indicates a potentially hazardous situation and if not avoided, may result in serious injury or death.



Indicates a potentially hazardous situation and if not avoided, may result in minor to moderate injury or serious damage to the product.



Indicates an improper action that it is not recommended to do and if doing it may cause damage, malfunction and inability.

Unpacking Check



- *Please ensure that both the servo drive and motor are correctly matched for size (power rating). Failure to observe this precaution may cause fire, seriously damage the drive / motor or cause personal injury.*

Installation



- Do not install the product in a location that is outside the stated specification for the drive and motor. Failure to observe this caution may result in electric shock, fire, or personal injury.

Wiring



- Connect the ground terminals to a class-3 ground (Ground resistance should not exceed 100 Ω). Improper grounding may result in electric shock or fire.
- Do not connect any power supplies to the U, V, W terminals. Failure to observe this precaution may result in serious injury, damage to the drive or fire.
- Ensure that all screws, connectors and wire terminations are secure on the power supply, servo drive and motor. Failure to observe this caution may result in damage, fire or personal injury.
- In order to prevent fire hazard and accidents, please form the wiring by the cable specifications outlined in this user manual.

Operation



- Before starting the operation with a mechanical system connected, change the drive parameters to match the user-defined parameters of the mechanical system. Starting the operation without matching the correct parameters may result in servo drive or motor damage, or damage to the mechanical system.
- Ensure that the emergency stop equipment or device is connected and working correctly before operating the motor that is connected to a mechanical system.



- Do not approach or touch any rotating parts (e.g. shaft) while the motor is running. Failure to observe this precaution may cause serious personal injury.



- In order to prevent accidents, the initial trial run for servo motor should be conducted under no load conditions (separate the motor from its couplings and belts).
- For the initial trial run, do not operate the servo motor while it is connected to its mechanical system. Connecting the motor to its mechanical system may cause damage or result in personal injury during the trail run. Connect the servo motor once it has successfully completed a trail run.
- Caution: Please perform trial run without load first and then perform trial run with load connected. After the servo motor is running normally and regularly without load, then run servo motor with load connected. Ensure to perform trial run in this order to prevent unnecessary danger.
- Do not touch either the drive heat sink or the motor during operation as they may become hot and personal injury may result.

Maintenance and Inspection



- Do not touch any internal or exposed parts of servo drive and servo motor as electrical shock may result.
- Do not remove the operation panel while the drive is connected to an electrical power source otherwise electrical shock may result.
- Wait at least 10 minutes after power has been removed before touching any drive or motor terminals or performing any wiring and/or inspection as an electrical charge may still remain in the servo drive and servo motor with hazardous voltages even after power has been removed.
- Do not disassemble the servo drive or motor as electric shock may result.
- Do not connect or disconnect wires or connectors while power is applied to the drive and motor.
- Only qualified personnel who have electrical knowledge should conduct maintenance and inspection.

Main Circuit Wiring



- Install the encoder cables in a separate conduit from the motor power cables to avoid signal noise. Separate the conduits by 30cm (11.8inches) above.
- Use multi-stranded twisted-pair wires or multi-core shielded-pair wires for signal, encoder (PG) feedback cables. The maximum length of command input cable is 3m (9.84ft.) and the maximum length of encoder (PG) feedback cables is 20m (65.62ft.).
- As a charge may still remain in the drive with hazardous voltages even after power has been removed, be sure to wait at least 10 minutes after power has been removed before performing any wiring and/or inspection.



- It is not recommended to frequently power the drive on and off. Do not turn the drive off and on more than once per minute as high charging currents within the internal capacitors may cause damage.

Preface | ASDA-A&A+ Series

Main Circuit Terminal Wiring



- Please perform the wiring after the terminal blocks are all removed from the drive.
- Insert only one wire into one terminal on the terminal block.
- When inserting wires, please ensure that the conductors are not shorted to adjacent terminals or wires.
- Ensure to double check the wiring before applying power to the drive.
- If the wiring is in error, perform the wiring again with proper tools. Never use force to remove the terminals or wires. Otherwise, it may result in malfunction or damage.



NOTE

- 1) In this manual, actual measured values are in metric units. Dimensions in (imperial units) are for reference only. Please use metric for precise measurements.
- 2) The content of this manual may be revised without prior notice. Please consult our distributors or download the most updated version at <http://www.delta.com.tw/industrialautomation>.

Table of Contents

Chapter 1	Unpacking Check and Model Explanation.....	1-1
1.1	Unpacking Check.....	1-1
1.2	Model Explanation.....	1-2
1.2.1	Nameplate Information	1-2
1.2.2	Model Name Explanation	1-4
1.3	Servo Drive and Servo Motor Combinations.....	1-7
1.4	Servo Drive Features	1-9
1.5	Control Modes of Servo Drive.....	1-13
Chapter 2	Installation and Storage.....	2-1
2.1	Installation Notes.....	2-1
2.2	Storage Conditions.....	2-1
2.3	Installation Conditions	2-2
2.4	Installation Procedure and Minimum Clearances	2-3
Chapter 3	Connections and Wiring	3-1
3.1	Connections	3-1
3.1.1	Connecting to Peripheral Devices	3-1
3.1.2	Servo Drive Connectors and Terminals	3-4
3.1.3	Wiring Methods.....	3-6
3.1.4	Motor Power Cable Connector Specifications.....	3-8
3.1.5	Encoder Connector Specifications	3-10
3.1.6	Cable Specifications for Servo Drive.....	3-11

Table of Contents | ASDA-A&A+ Series

3.2	Basic Wiring	3-13
3.3	Input / Output Interface Connector -CN1	3-17
3.3.1	CN1 Terminal Identification	3-17
3.3.2	Signals Explanation of Connector CN1	3-19
3.3.3	User-defined DI and DO signals.....	3-29
3.3.4	Wiring Diagrams of I/O Signals (CN1).....	3-30
3.4	Encoder Connector CN2.....	3-35
3.5	Serial Communication Connector CN3.....	3-37
3.5.1	CN3 Terminal Layout and Identification	3-37
3.5.2	Connection between PC/Keypad and Connector CN3	3-38
3.6	Standard Connection Example	3-39
3.6.1	Position (Pt) Control Mode	3-39
3.6.2	Position (Pr) Control Mode	3-40
3.6.3	Speed Control Mode.....	3-41
3.6.4	Torque Control Mode.....	3-42
Chapter 4	Display and Operation.....	4-1
4.1	Description of the Digital Keypad.....	4-1
4.2	Display Flowchart.....	4-3
4.3	Status Display	4-4
4.3.1	Save Setting Display	4-4
4.3.2	Abort Setting Display	4-4
4.3.3	Fault Message Display	4-4
4.3.4	Polarity Setting Display.....	4-4
4.3.5	Monitor Setting Display.....	4-5
4.4	General Function Operation.....	4-7

Table of Contents | ASDA-A&A+ Series

4.4.1	Fault Code Display Operation	4-7
4.4.2	JOG Operation.....	4-7
4.4.3	Position Learning Operation	4-8
4.4.4	DO Force Output Diagnosis Operation	4-10
4.4.5	DI Diagnosis Operation	4-11
4.4.6	DO Diagnosis Operation.....	4-11
Chapter 5	Trial Run and Tuning Procedure	5-1
5.1	Inspection without Load	5-1
5.2	Applying Power to the Drive.....	5-3
5.3	JOG Trial Run without Load.....	5-7
5.4	Speed Trial Run without Load.....	5-9
5.5	Position Trial Run without Load	5-11
5.6	Tuning Procedure.....	5-14
5.6.1	Tuning Flowchart	5-15
5.6.2	Load Inertia Estimation Flowchart	5-16
5.6.3	Easy Mode Tuning Flowchart.....	5-17
5.6.4	AutoMode (PI) Tuning Flowchart.....	5-20
5.6.5	AutoMode (PDFF) Tuning Flowchart.....	5-22
5.6.6	Limit of Load Inertia Estimation	5-24
5.6.7	Relationship between Tuning Modes and Parameters	5-24
5.6.8	Gain Adjustment in Manual Mode	5-25
Chapter 6	Control Modes of Operation	6-1
6.1	Control Modes of Operation	6-1
6.2	Position Control Mode.....	6-2
6.2.1	Command Source of Position (Pt) Control Mode	6-2

Table of Contents | ASDA-A&A+ Series

6.2.2	Command Source of Position (Pr) Control Mode	6-4
6.2.3	Structure of Position Control Mode	6-5
6.2.4	P-curve Filter for Position Control.....	6-6
6.2.5	Electronic Gear Ratio	6-9
6.2.6	Low-pass Filter	6-10
6.2.7	Timing Chart of Position (Pr) Control Mode	6-11
6.2.8	Position Loop Gain Adjustment	6-11
6.3	Speed Control Mode	6-14
6.3.1	Command Source of Speed Control Mode	6-14
6.3.2	Structure of Speed Control Mode	6-15
6.3.3	Smoothing Strategy of Speed Control Mode.....	6-16
6.3.4	Analog Speed Input Scaling	6-19
6.3.5	Timing Chart of Speed Control Mode.....	6-20
6.3.6	Speed Loop Gain Adjustment.....	6-20
6.3.7	Resonance Suppression	6-28
6.4	Torque Control Mode	6-31
6.4.1	Command Source of Torque Control Mode	6-31
6.4.2	Structure of Torque Control Mode	6-32
6.4.3	Smoothing Strategy of Torque Control Mode.....	6-32
6.4.4	Analog Torque Input Scaling	6-33
6.4.5	Timing Chart of Speed Control Mode.....	6-34
6.5	Control Modes Selection	6-35
6.5.1	Speed / Position Control Mode Selection	6-35
6.5.2	Speed / Torque Control Mode Selection	6-36
6.5.3	Torque / Position Control Mode Selection	6-36

Table of Contents | ASDA-A&A+ Series

6.6	Others.....	6-38
6.6.1	Speed Limit.....	6-38
6.6.2	Torque Limit.....	6-38
6.6.3	Regenerative Resistor.....	6-39
6.6.4	Analog Monitor.....	6-44
6.6.5	Electromagnetic Brake.....	6-47
Chapter 7	Parameters.....	7-1
7.1	Definition.....	7-1
7.2	Parameter Summary.....	7-2
7.2.1	Parameters List by Group.....	7-2
7.2.2	Parameters List by Function.....	7-9
7.3	Detailed Parameter Listings.....	7-20
Chapter 8	MODBUS Communications.....	8-1
8.1	Communication Hardware Interface.....	8-1
8.2	Communication Parameter Settings.....	8-5
8.3	MODBUS Communication Protocol.....	8-9
8.4	Communication Parameter Write-in and Read-out.....	8-17
Chapter 9	Maintenance and Inspection.....	9-1
9.1	Basic Inspection.....	9-1
9.2	Maintenance.....	9-2
9.3	Life of Replacement Components.....	9-2
Chapter 10	Troubleshooting.....	10-1
10.1	Fault Messages Table.....	10-1
10.2	Potential Cause and Corrective Actions.....	10-3
10.3	Clearing Faults.....	10-9

Table of Contents | ASDA-A&A+ Series

Chapter 11	Specifications	11-1
11.1	Specifications of Servo Drive (ASDA-A Series).....	11-1
11.2	Specifications of Servo Drive (ASDA-A+ Series).....	11-4
11.3	Low Inertia Servo Motor Specifications (ASMT□□L Series)	11-6
11.4	Medium Inertia Servo Motor Specifications (ASMT□□M Series)	11-8
11.5	Medium and Medium / High Inertia Servo Motor Specifications (ECMA Series).....	11-10
11.6	Servo Motor Speed-Torque Curves (T-N Curves).....	11-11
11.7	Overload Characteristics.....	11-13
11.8	Dimensions of Servo Drive.....	11-15
11.9	Dimensions of Low Inertia Servo Motor (ASMT□□L Series).....	11-21
11.10	Dimensions of Medium Inertia Servo Motor (ASMT□□M Series)	11-23
11.11	Dimensions of Medium / High Inertia Servo Motor (ECMA Series).....	11-24
Chapter 12	Application Examples	12-1
12.1	Position Control (including homing function).....	12-1
12.2	Roller Feeding.....	12-3
12.3	Connecting to Delta DVP-EH Series PLC.....	12-4
12.4	Connecting to Delta TP04 Series.....	12-9
12.5	Position Control Mode (Pr Mode).....	12-11
12.6	Feed Step Control	12-14
12.7	Internal Auto Running Mode	12-25
12.8	Homing Function	12-30
12.9	External Controller Connection Examples	12-37
Appendix A	Accessories	A-1
Appendix B	Molded-case Circuit Breaker, Fuse Current and EMI Filters	B-1

Table of Contents | ASDA-A&A+ Series**About this Manual...****User Information**

Be sure to store this manual in a safe place.

Due to constantly growing product range, technical improvement and alteration or changed texts, figures and diagrams, we reserve the right of this manual contained information change without prior notice.

Coping or reproducing any part of this manual, without written consent of Delta Electronics Inc. is prohibited.

Technical Support and Service

Welcome to contact us or visit our web site (<http://www.delta.com.tw/industrialautomation/>) if you need any technical support, service and information, or, if you have any question in using the product. We are looking forward to serve you needs and willing to offer our best support and service to you. Reach us by the following ways.

ASIA

DELTA ELECTRONICS, INC.
Taoyuan Plant 1
31-1, XINGBANG ROAD,
GUISHAN INDUSTRIAL ZONE,
TAOYUAN COUNTY 33370, TAIWAN, R.O.C.
TEL: 886-3-362-6301
FAX: 886-3-362-7267

JAPAN

DELTA ELECTRONICS (JAPAN), INC.
Tokyo Office
DELTA SHIBADAIMON BUILDING
2-1-14 SHIBADAIMON, MINATO-KU,
TOKYO, 105-0012, JAPAN
TEL: 81-3-5733-1111
FAX: 81-3-5733-1211

NORTH/SOUTH AMERICA

DELTA PRODUCTS CORPORATION (USA)
Raleigh Office
P.O. BOX 12173
5101 DAVIS DRIVE,
RESEARCH TRIANGLE PARK, NC 27709, U.S.A.
TEL: 1-919-767-3813
FAX: 1-919-767-3969

EUROPE

DELTRONICS (THE NETHERLANDS) B.V.
Eindhoven Office
DE WITBOGT 15, 5652 AG EINDHOVEN,
THE NETHERLANDS
TEL: 31-40-259-2850
FAX: 31-40-259-2851

Table of Contents | ASDA-A&A+ Series

This page intentionally left blank.

Chapter 1 Unpacking Check and Model Explanation

1.1 Unpacking Check

After receiving the AC servo drive, please check for the following:

- **Ensure that the product is what you have ordered.**

Verify the part number indicated on the nameplate corresponds with the part number of your order (Please refer to Section 1.2 for details about the model explanation).

- **Ensure that the servo motor shaft rotates freely.**

Rotate the motor shaft by hand; a smooth rotation will indicate a good motor. However, a servo motor with an electromagnetic brake can not be rotated manually.

- **Check for damage.**

Inspect the unit to insure it was not damaged during shipment.

- **Check for loose screws.**

Ensure that all necessary screws are tight and secure.

If any items are damaged or incorrect, please inform the distributor whom you purchased the product from or your local Delta sales representative.

A complete and workable AC servo system should be including the following parts:

Part I : Delta standard supplied parts

- (1) Servo drive
- (2) Servo motor
- (3) 5 PIN Terminal Block (for L1, L2, R, S, T) (available for 100W ~ 1.5kW models)
- (4) 3 PIN Terminal Block (for U, V, W) (available for 100W ~ 1.5kW models)
- (5) 3 PIN Terminal Block (for P, D, C) (available for 100W ~ 1.5kW models)
- (6) One operating lever (for wire to terminal block insertion; available for 100W ~ 1.5kW models)
- (7) One jumper bar (for short the circuit of the terminal pins; available for 2kW ~ 4.5kW models)
- (8) Quick Start

Part II : Optional parts, not Delta standard supplied part (Refer to Appendix A)

- (1) One power cable, which is used to connect servo motor and U, V, W terminals of servo drive. This power cable is with one green grounding cable. Please connect the green grounding cable to the ground terminal of the servo drive.

Chapter 1 Unpacking Check and Model Explanation | ASDA-A&A+ Series

- (2) One encoder cable, which is used to connect the encoder of servo motor and CN2 terminal of servo drive.
- (3) CN1 Connector: 50 PIN Connector (3M type analog product)
- (4) CN2 Connector: 20 PIN Connector (3M type analog product)
- (5) CN3 Connector: 6 PIN Connector (IEEE1394 analog product)

1.2 Model Explanation

1.2.1 Nameplate Information

ASDA-A Series Servo Drive

■ Nameplate Explanation

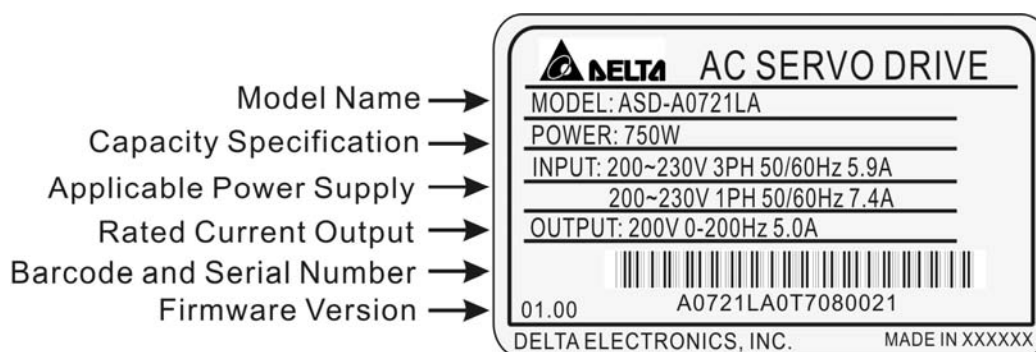

■ Serial Number Explanation

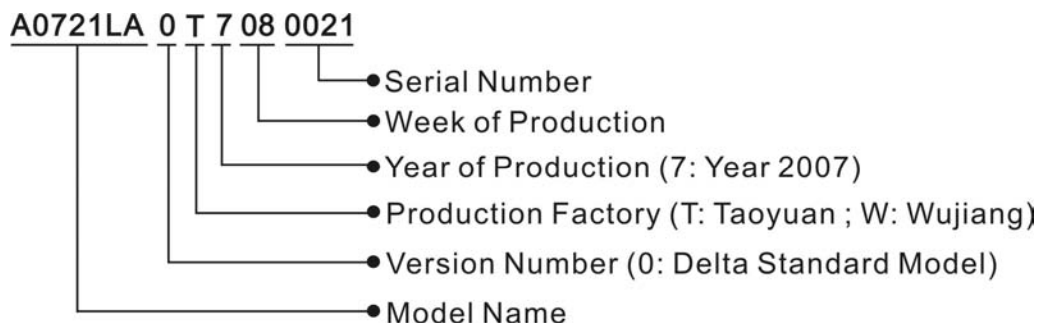

ASMT Series Servo Motor

■ Nameplate Explanation

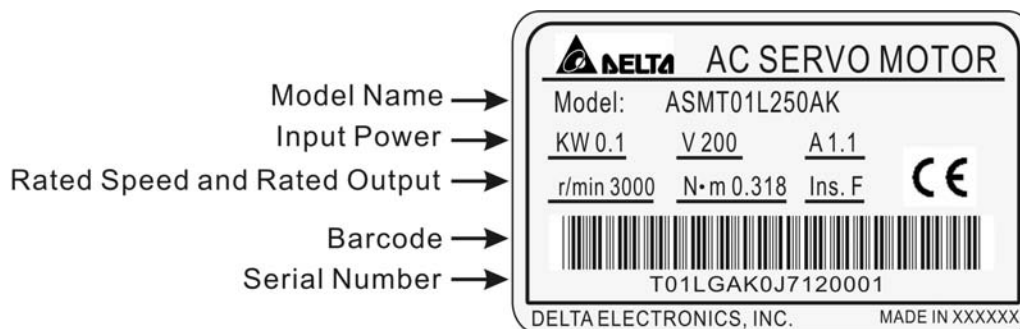

Chapter 1 Unpacking Check and Model Explanation | ASDA-A&A+ Series

Serial Number Explanation

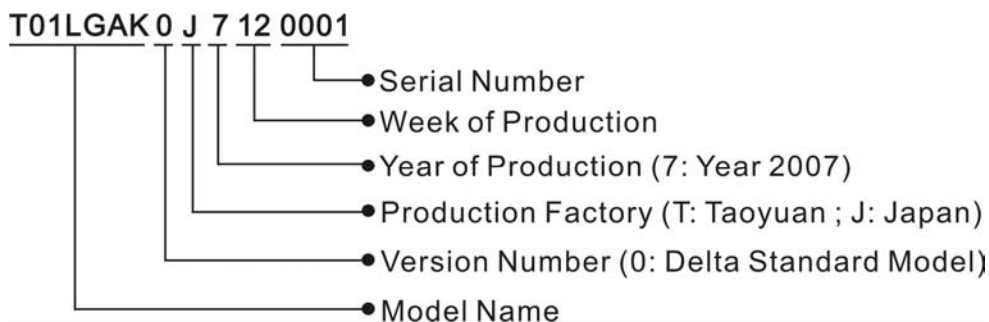

ASDA-A+ Series Servo Drive

Nameplate Explanation

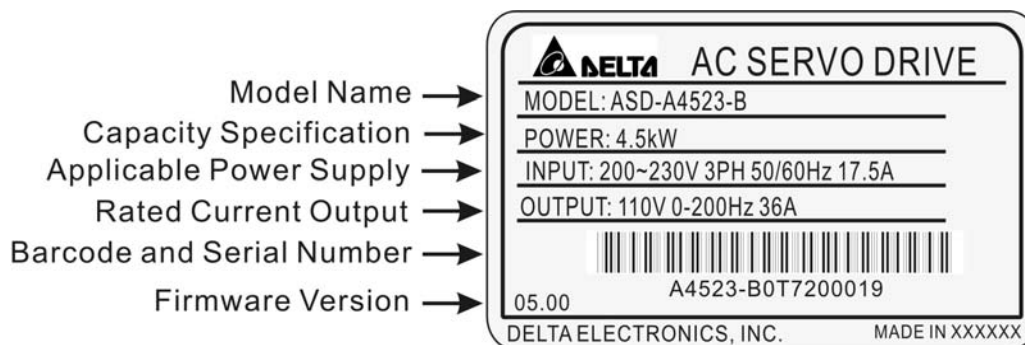

Serial Number Explanation

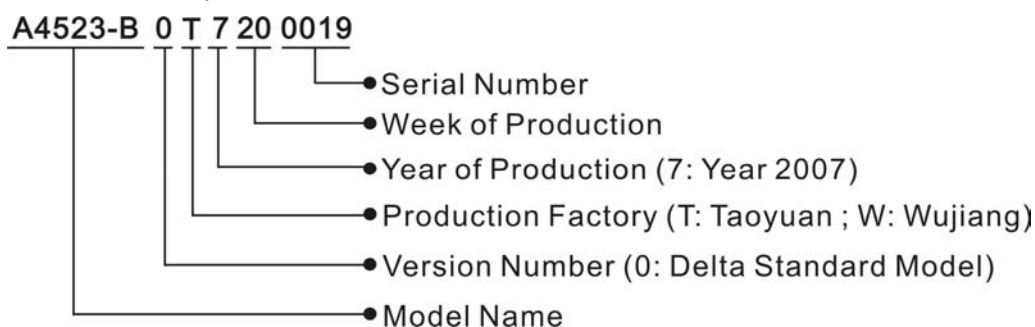

ECMA Series Servo Motor

Nameplate Explanation

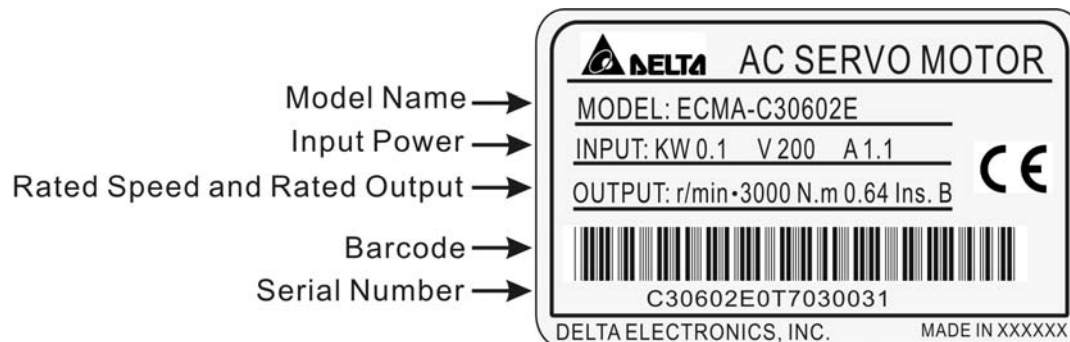

Chapter 1 Unpacking Check and Model Explanation | ASDA-A&A+ Series

Serial Number Explanation

C30602E 0 T 7 03 0031

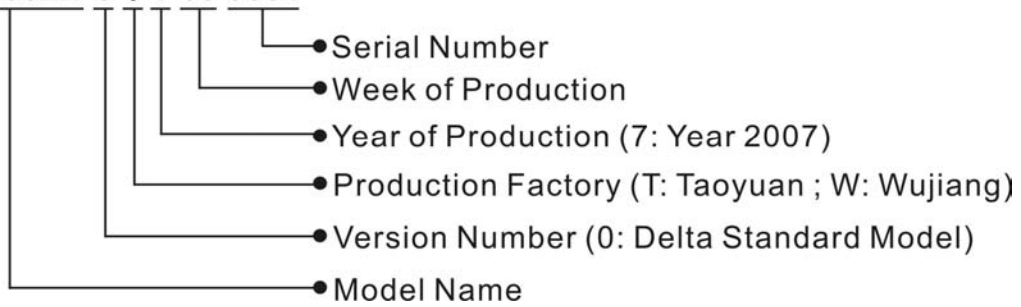

1.2.2 Model Name Explanation

ASDA-A Series Servo Drive

A S D - A 0 7 2 3 L A

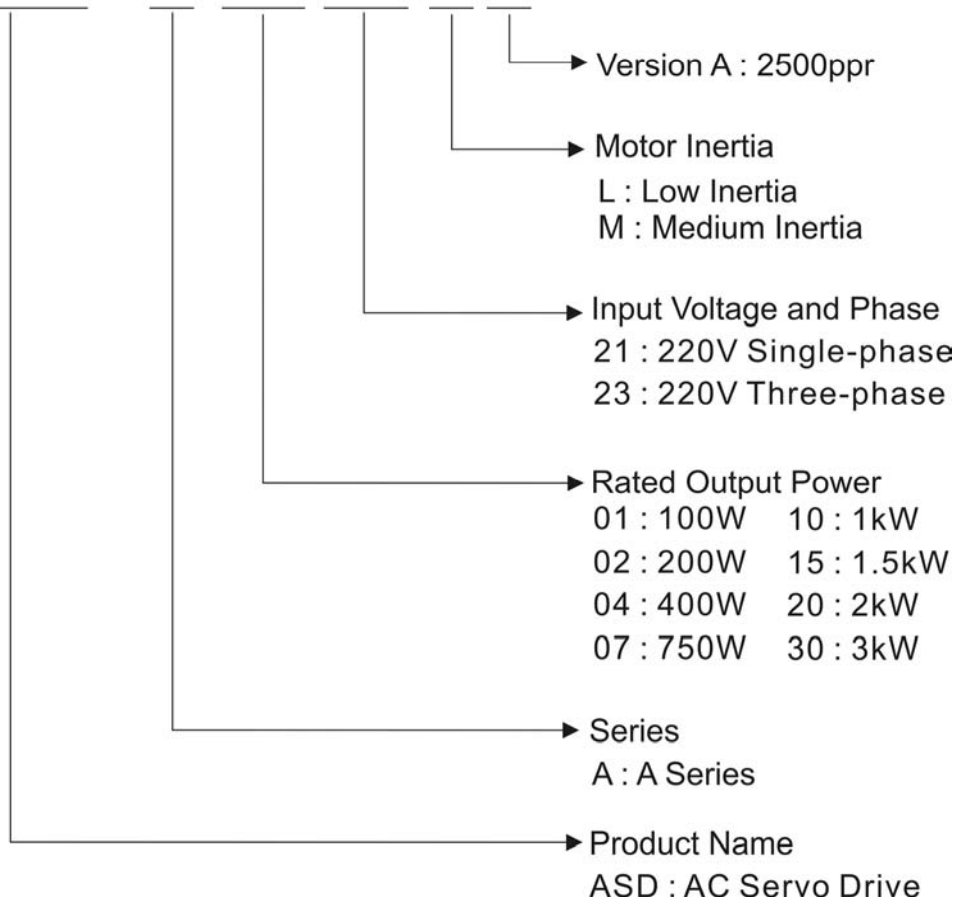

Chapter 1 Unpacking Check and Model Explanation | ASDA-A&A+ Series

ASMT Series Servo Motor

A S M T 0 1 L 2 5 0 A K

Symbol	Keyway	Oil Seal
K	Yes	No
O	No	Yes
M	Yes	Yes

Electromagnetic Brake
 A : Without Electromagnetic Brake
 B : With Electromagnetic Brake

Encoder Resolution
 250 : 2500ppr

Motor Inertia
 L : Low Inertia
 M : Medium Inertia

Rated Output Power
 01 : 100W 10 : 1kW
 02 : 200W 15 : 1.5kW
 04 : 400W 20 : 2kW
 07 : 750W 30 : 3kW

Motor Type
 T : T Type

Product Name
 ASM : AC Servo Motor

Chapter 1 Unpacking Check and Model Explanation | ASDA-A&A+ Series

ASDA-A+ Series Servo Drive

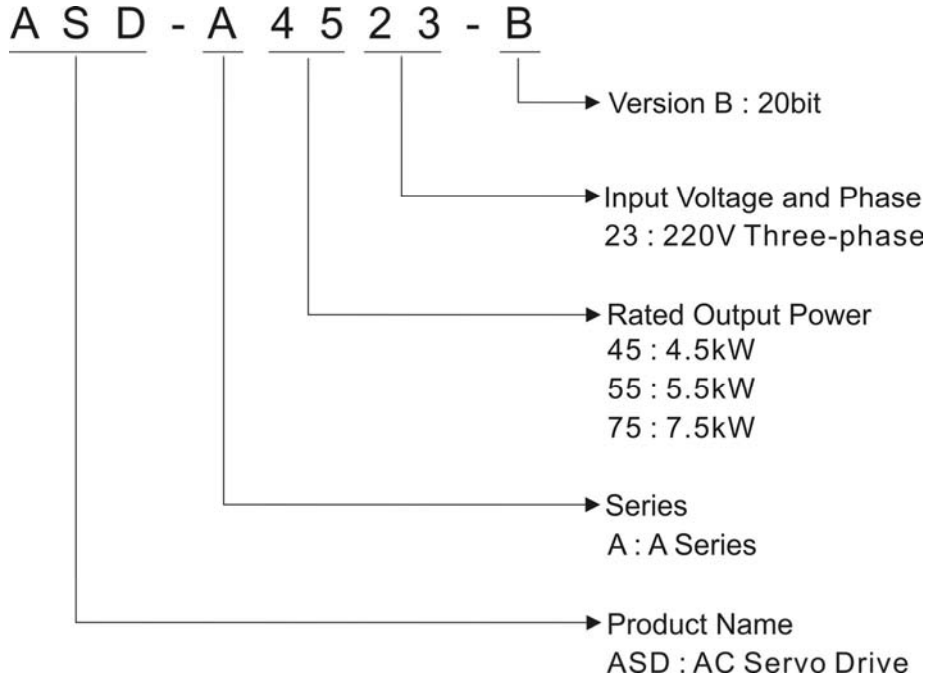

ECMA Series Servo Motor

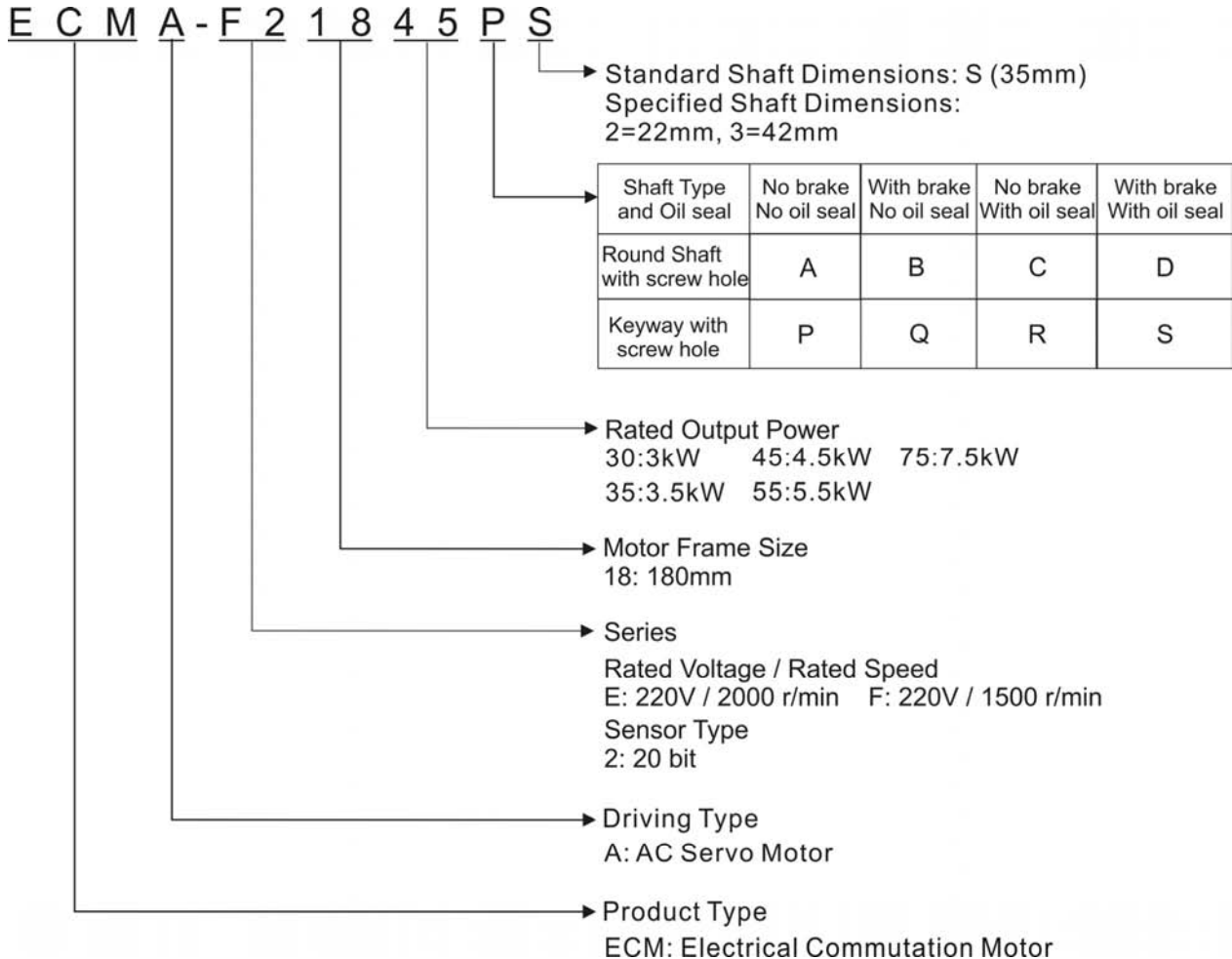

Chapter 1 Unpacking Check and Model Explanation | ASDA-A&A+ Series





1.3 Servo Drive and Servo Motor Combinations

The table below shows the possible combination of Delta ASDA-A and ASDA-A+ series servo drives and ASMT and ECMA series servo motors. The boxes (□) in the model names are for optional configurations. (Please refer to Section 1.2 for model explanation)

ASDA-A Series Servo Drive

		Servo drive		Servo motor	
Low inertia	100W	ASD-A0121L□		ASMT01L250□□	
	200W	ASD-A0221L□		ASMT02L250□□	
	400W	ASD-A0421L□		ASMT04L250□□	
	750W	ASD-A0721L□		ASMT07L250□□	
	1000W	ASD-A1021L□		ASMT10L250□□	
	2000W	ASD-A2023L□		ASMT20L250□□	
	3000W	ASD-A3023L□		ASMT30L250□□	
Medium inertia	1000W	ASD-A1021M□		ASMT10M250□□	
	1500W	ASD-A1521M□		ASMT15M250□□	
	2000W	ASD-A2023M□		ASMT20M250□□	
	3000W	ASD-A3023M□		ASMT30M250□□	

Chapter 1 Unpacking Check and Model Explanation | ASDA-A&A+ Series**ASDA-A+ Series Servo Drive**

	Servo drive		Servo motor	
4500W	ASD-A4523-B		ECMA-F21830□S	
			ECMA-E21835□S	
			ECMA-F21845□S	
5500W	ASD-A5523-B		ECMA-F21855□3	
7500W	ASD-A7523-B		ECMA-F21875□3	

The drives shown in the above table are designed for use in combination with the specific servo motors. Check the specifications of the drives and motors you want to use.

Also, please ensure that both the servo drive and motor are correctly matched for size (power rating). If the power of motor and drive is not within the specifications, the drive and motor may overheat and servo alarm would be activated. For the detail specifications of servo drives and motors, please refer to Chapter 11 "Specifications".

The drives shown in the above table are designed according to the three multiple of rated current of motors shown in the above table. If the drives which are designed according to the six multiple of rated current of motors are needed, please contact our distributors or your local Delta sales representative.

Chapter 1 Unpacking Check and Model Explanation | ASDA-A&A+ Series

1.4 Servo Drive Features

ASDA-A Series Servo Drive

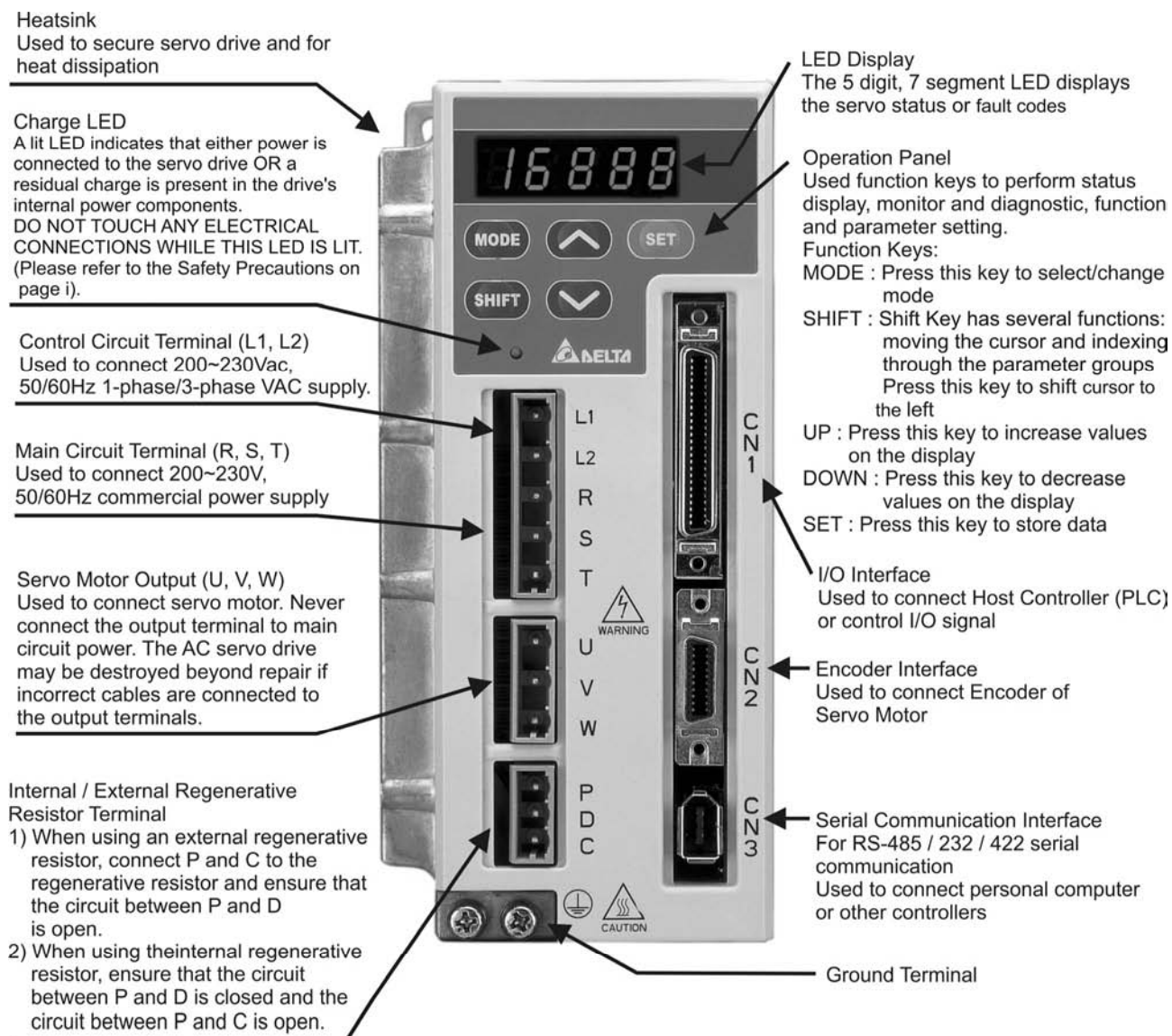

Chapter 1 Unpacking Check and Model Explanation | ASDA-A&A+ Series

ASDA-A+ Series Servo Drive (4.5 kW)

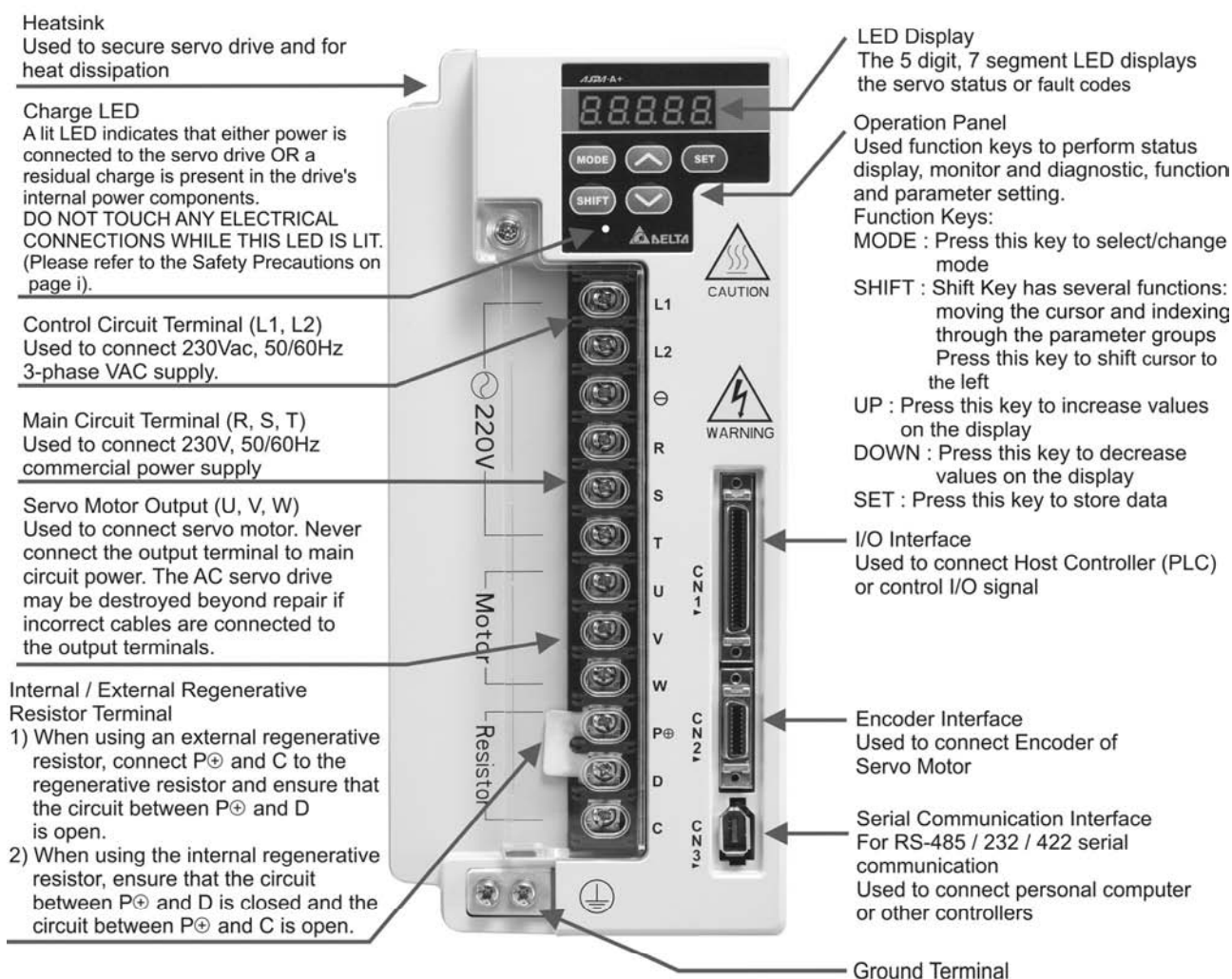

Chapter 1 Unpacking Check and Model Explanation | ASDA-A&A+ Series

ASDA-A+ Series Servo Drive (5.5 kW)

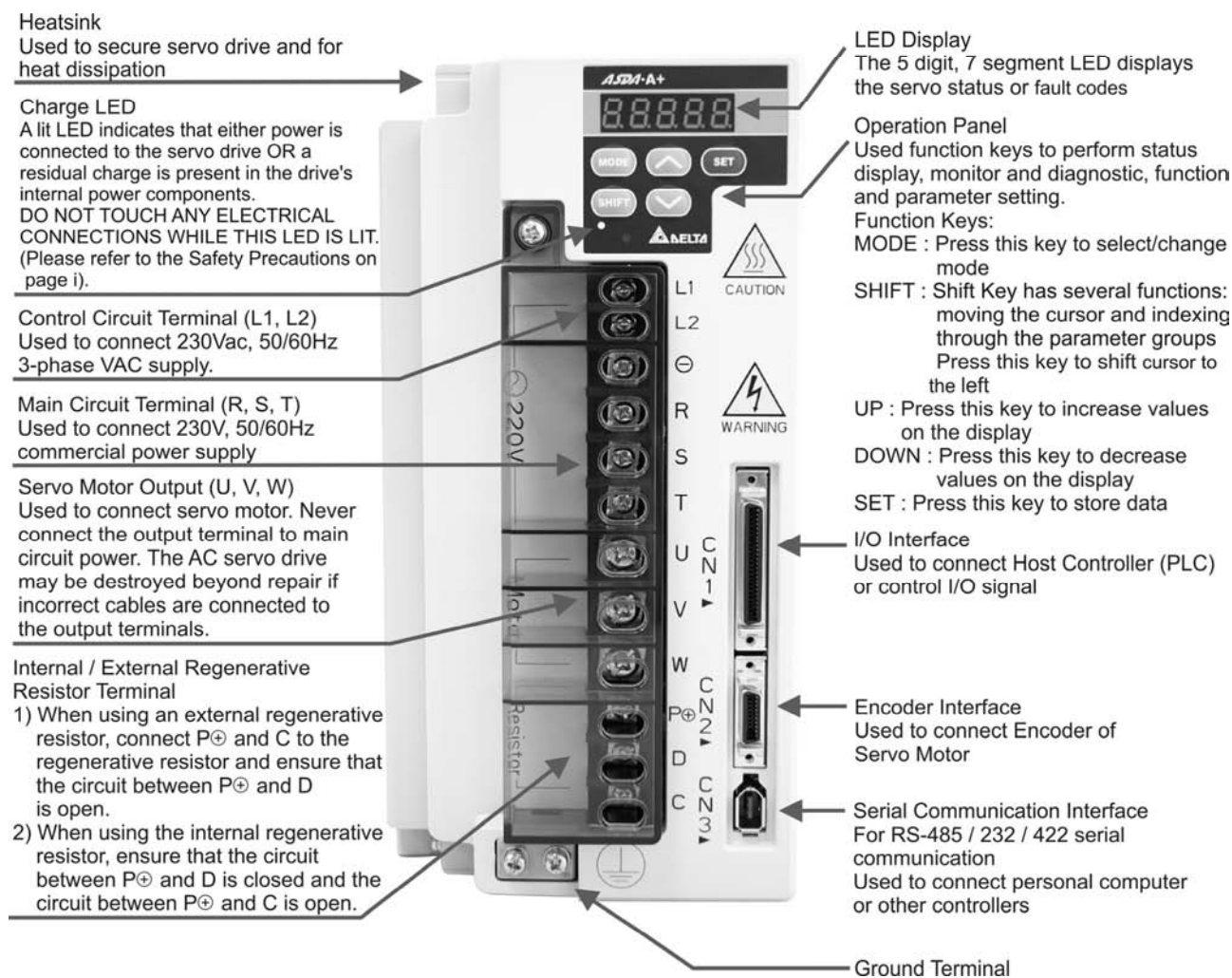

Chapter 1 Unpacking Check and Model Explanation | ASDA-A&A+ Series

ASDA-A+ Series Servo Drive (7.5 kW)

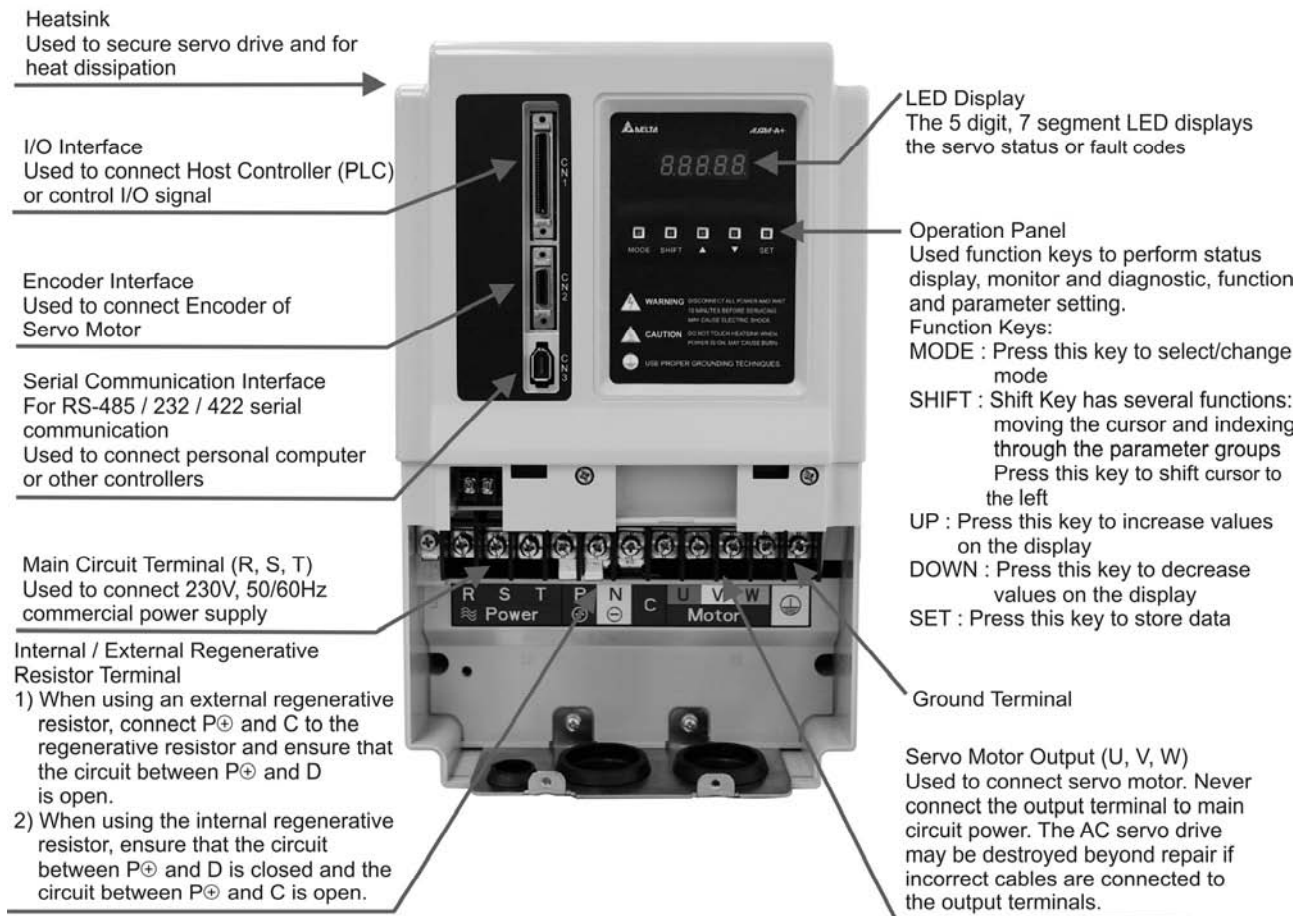

Chapter 1 Unpacking Check and Model Explanation | ASDA-A&A+ Series

1.5 Control Modes of Servo Drive

The Delta Servo can be programmed to provide six single and five dual modes of operation.

Their operation and description is listed in the following table.

Mode		Code	Description
Single Mode	External Position Control	Pt	Position control for the servo motor is achieved via an external pulse command.
	Internal Position Control	Pr	Position control for the servo motor is achieved via by 8 commands stored within the servo controller. Execution of the 8 positions is via Digital Input (DI) signals.
	Speed Control	S	Speed control for the servo motor can be achieved via parameters set within the controller or from an external analog -10 ~ +10 Vdc command. Control of the internal speed parameters is via the Digital Inputs (DI). (A maximum of three speeds can be stored internally).
	Internal Speed Control	Sz	Speed control for the servo motor is only achieved via parameters set within the controller. Control of the internal speed parameters is via the Digital Inputs (DI). (A maximum of three speeds can be stored internally).
	Torque Control	T	Torque control for the servo motor can be achieved via parameters set within the controller or from an external analog -10 ~ +10 Vdc command. Control of the internal torque parameters is via the Digital Inputs (DI). (A maximum of three torque levels can be stored internally).
	Internal Torque Control	Tz	Torque control for the servo motor is only achieved via parameters set within the controller. Control of the internal torque parameters is via the Digital Inputs (DI). (A maximum of three torque levels can be stored internally).
Dual Mode		Pt-S	Either Pt or S control mode can be selected via the Digital Inputs (DI)
		Pt-T	Either Pt or T control mode can be selected via the Digital Inputs (DI)
		Pr-S	Either Pr or S control mode can be selected via the Digital Inputs (DI)
		Pr-T	Either Pr or T control mode can be selected via the Digital Inputs (DI)
		S-T	Either S or T control mode can be selected via the Digital Inputs (DI)

The above control modes can be accessed and changed via by parameter P1-01. If the control mode is changed, switch the drive off and on after the new control mode has been entered. The new control mode will only be valid after drive off/on action. Please see safety precautions on page iii (switching drive off/on multiple times).

Chapter 1 Unpacking Check and Model Explanation | ASDA-A&A+ Series

This page intentionally left blank.

Chapter 2 Installation and Storage

2.1 Installation Notes

Pay close attention on the following installation notes:

- Do not bend or strain the connection cables between servo drive and motor.
- When mounting servo drive, make sure to tighten screws to secure the drive in place.
- If the servo motor shaft is coupled directly to a rotating device ensure that the alignment specifications of the servo motor, coupling, and device are followed. Failure to do so may cause unnecessary loads or premature failure to the servo motor.
- If the length of cable connected between servo drive and motor is more than 20m, please increase the wire gauge of the encoder cable and motor connection cable (connected to U, V, W terminals).
- Make sure to tighten the screws for securing motor.

2.2 Storage Conditions

The product should be kept in the shipping carton before installation. In order to retain the warranty coverage, the AC servo drive should be stored properly when it is not to be used for an extended period of time. Some storage suggestions are:

- Store in a clean and dry location free from direct sunlight.
- Store within an ambient temperature range of -20°C to +65°C (-4°F to 149°F).
- Store within a relative humidity range of 0% to 90% and non-condensing.
- Do not store in a place subjected to corrosive gases and liquids.
- Correctly packaged and placed on a solid surface.

Chapter 2 Installation and Storage | ASDA-A&A+ Series

2.3 Installation Conditions

Operating Temperature

ASDA-A&A+ Series Servo Drive : 0°C to 55°C (32°F to 131°F)

ECMA Series Servo Motor : 0°C to 40°C (32°F to 104°F)

The ambient temperature of servo drive for long-term reliability should be under 45°C (113°F).

If the ambient temperature of servo drive is greater than 45°C (113°F), please install the drive in a well-ventilated location and do not obstruct the airflow for the cooling fan.

Caution

The servo drive and motor will generate heat. If they are installed in a control panel, please ensure sufficient space around the units for heat dissipation.

Pay particular attention to vibration of the units and check if the vibration has impacted the electric devices in the control panel. Please observe the following precautions when selecting a mounting location. **Failure to observe the following precautions may void the warranty!**

- Do not mount the servo drive or motor adjacent to heat-radiating elements or in direct sunlight.
- Do not mount the servo drive or motor in a location subjected to corrosive gases, liquids, or airborne dust or metallic particles.
- Do not mount the servo drive or motor in a location where temperatures and humidity will exceed specification.
- Do not mount the servo drive or motor in a location where vibration and shock will exceed specification.
- Do not mount the servo drive or motor in a location where it will be subjected to high levels of electromagnetic radiation.

Chapter 2 Installation and Storage | ASDA-A&A+ Series

2.4 Installation Procedure and Minimum Clearances

Installation Procedure

Incorrect installation may result in a drive malfunction or premature failure of the drive and or motor. Please follow the guidelines in this manual when installing the servo drive and motor.

The ASDA-A&A+ servo drive should be mounted perpendicular to the wall or in the control panel. In order to ensure the drive is well ventilated, ensure that the all ventilation holes are not obstructed and sufficient free space is given to the servo drive. Do not install the drive in a horizontal position or malfunction and damage will occur.

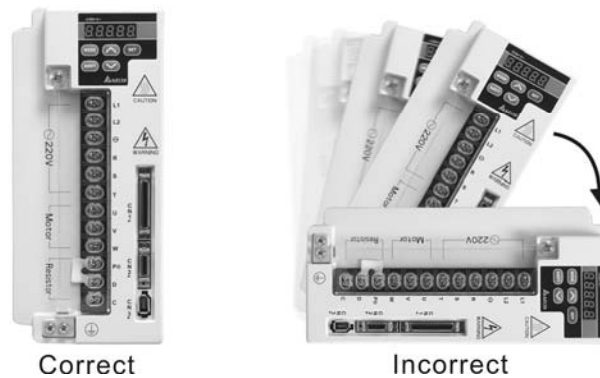

Correct

Incorrect

Drive Mounting

The ASDA-A&A+ Servo drives must be back mounted vertically on a dry and solid surface such as a NEMA enclosure. A minimum spacing of two inches must be maintained above and below the drive for ventilation and heat dissipation. Additional space may be necessary for wiring and cable connections. Also, as the drive conducts heat away via the mounting, the mounting plane or surface should be conductor away and not conduct heat into the drive from external sources

Motor Mounting

The ECMA Servo motors should be mounted firmly to a dry and solid mounting surface to ensure maximum heat transfer for maximum power output and to provide a good ground.

For the dimensions and weights specifications of servo drive or motor, please refer to Chapter 11 "Specifications".

Minimum Clearances

Install a fan to increase ventilation to avoid ambient temperatures that exceed the specification. When installing two or more drive adjacent to each other please follow the clearances as shown in the following diagram.

Chapter 2 Installation and Storage | ASDA-A&A+ Series

■ Minimum Clearances

For models of 5.5kW and below

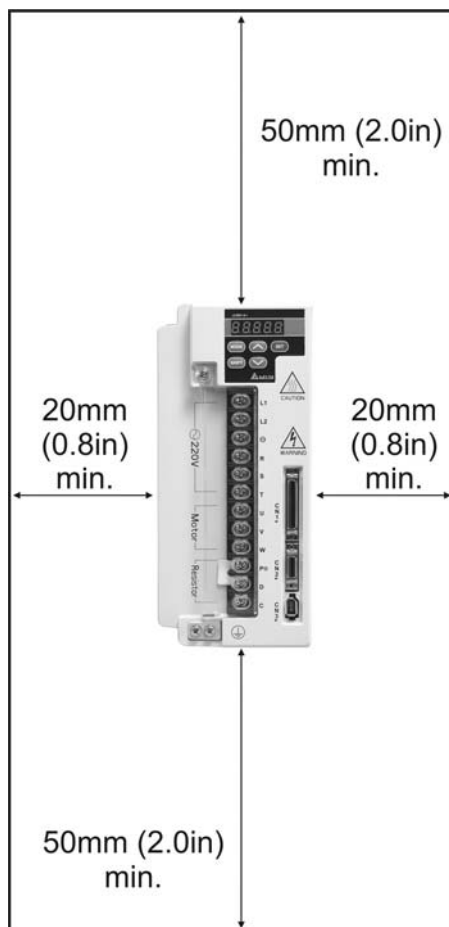

For 7.5kW model

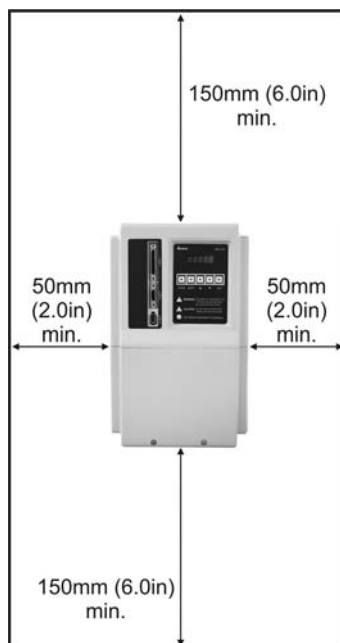

Chapter 2 Installation and Storage | ASDA-A&A+ Series

■ Side by Side Installation

For models of 5.5kW and below

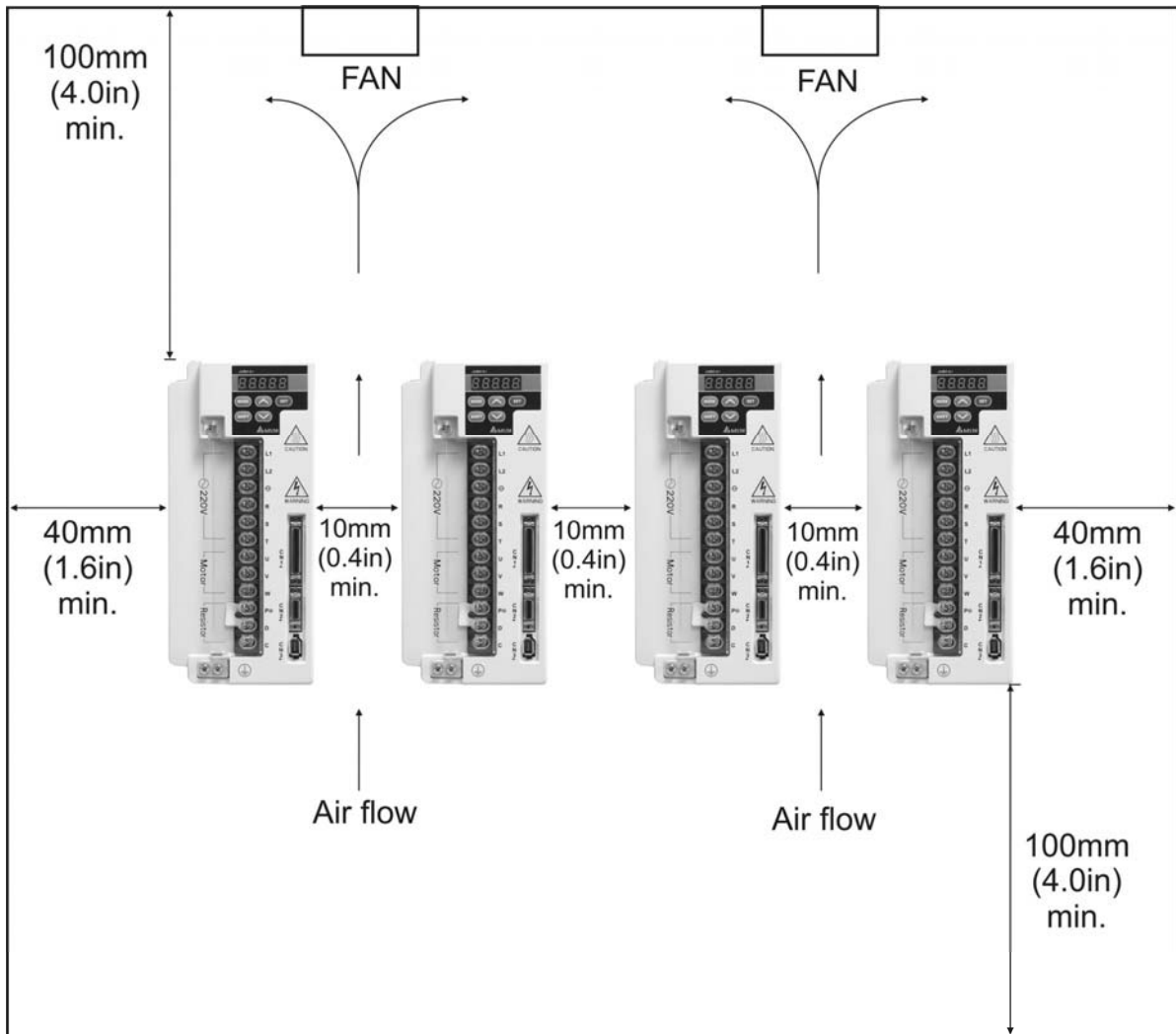

For 7.5kW model

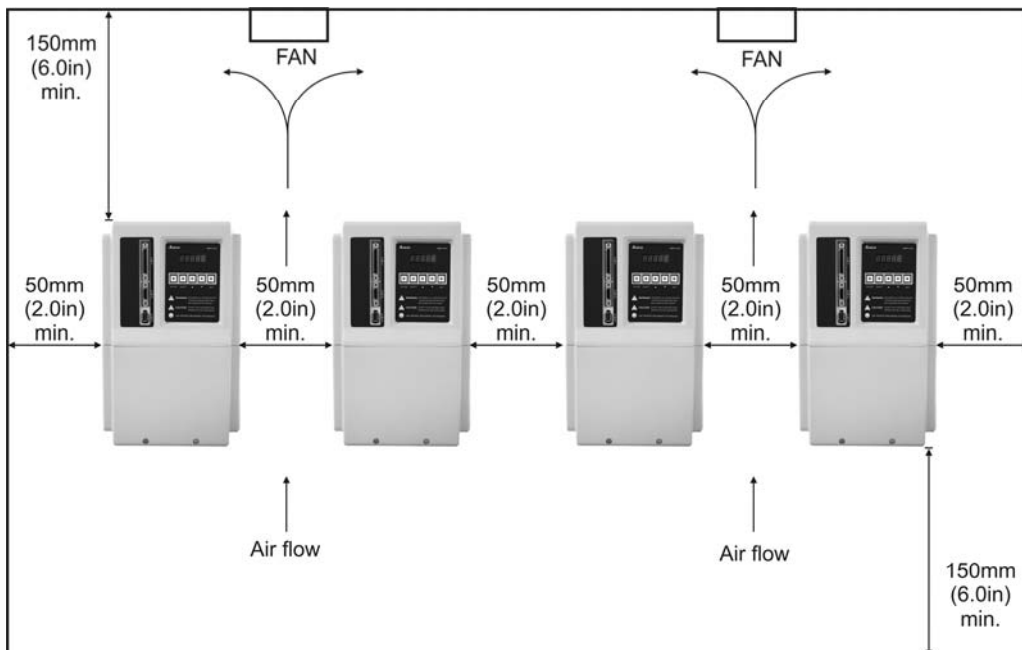

Chapter 2 Installation and Storage | ASDA-A&A+ Series

This page intentionally left blank.

Chapter 3 Connections and Wiring

This chapter provides information on wiring ASDA-A and ASDA-A+ series products, the descriptions of I/O signals and gives typical examples of wiring diagrams.

3.1 Connections

3.1.1 Connecting to Peripheral Devices

In Figure 3.1 and 3.2, it briefly explains how to connect each peripheral device.

Figure 3.1 (ASDA-A Series)

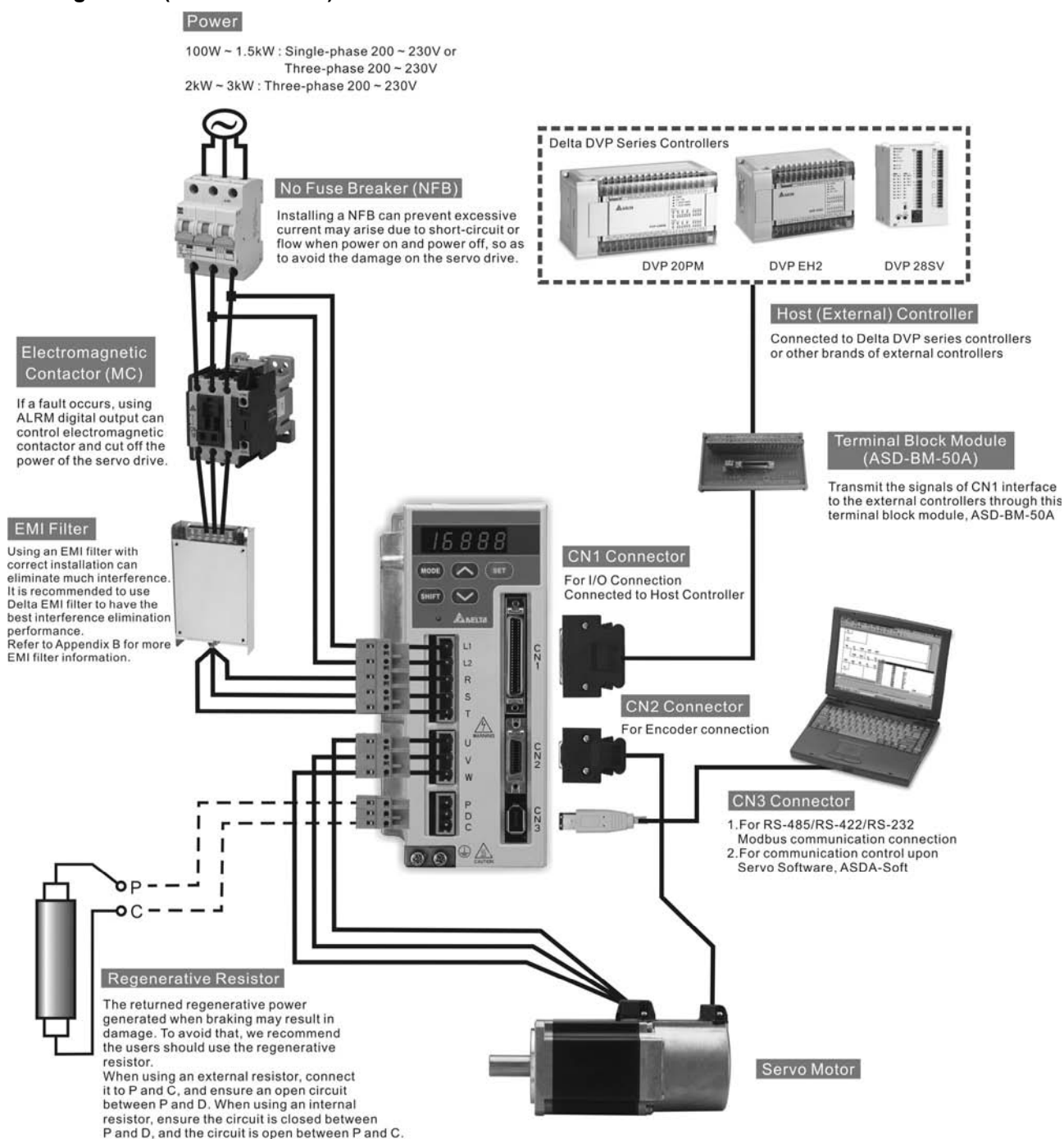

Chapter 3 Connections and Wiring | ASDA-A&A+ Series

Figure 3.2 (ASDA-A+ Series)

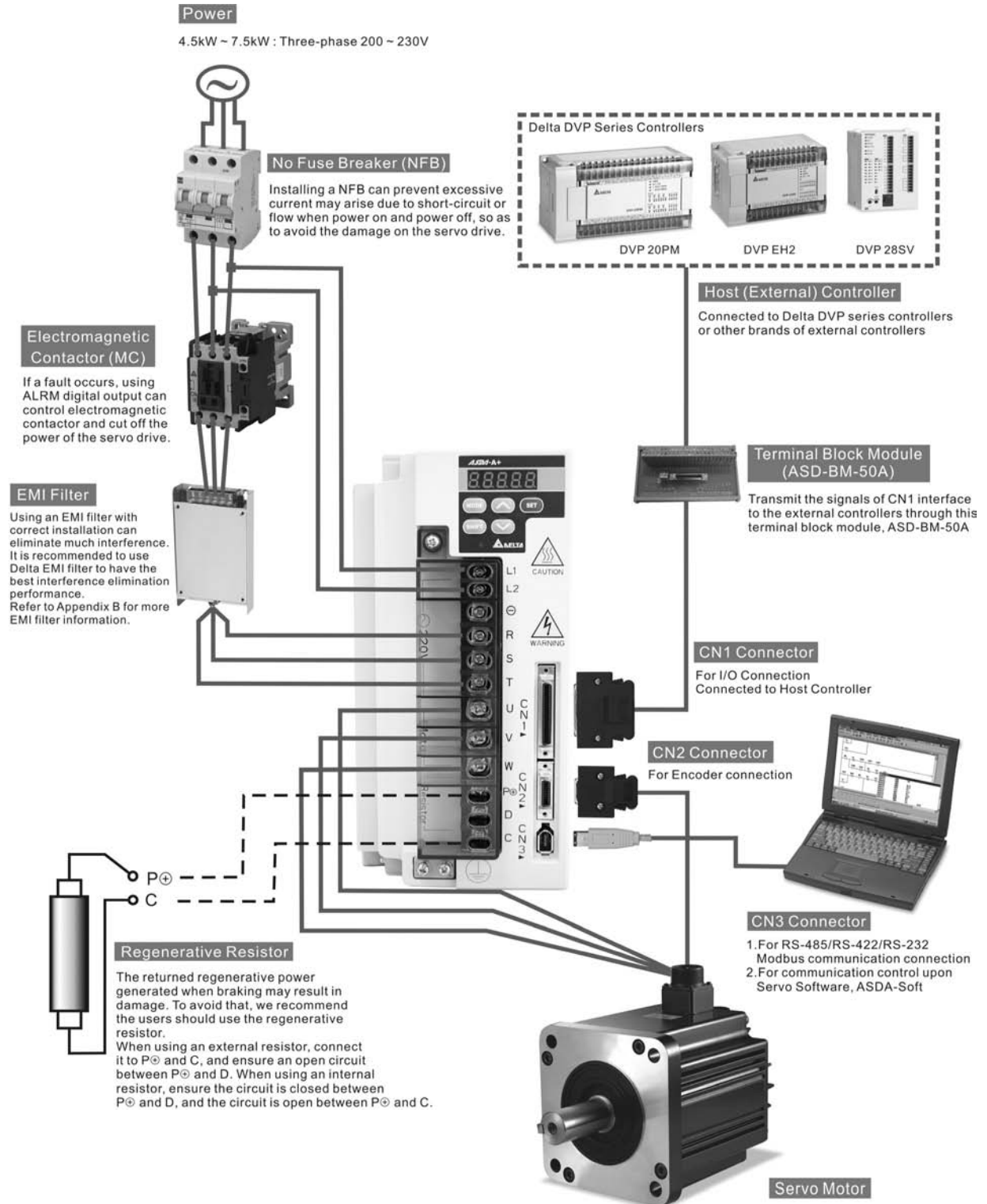

NOTE

- 1) CN1, CN2, CN3 connectors and terminal block module, ASD-BM-50A are all optional parts, not Delta standard supplied part (Refer to Appendix A).
- 2) Check if the wiring of control circuit power (L1, L2) and main circuit power (R, S, T) are correct.

Chapter 3 Connections and Wiring | ASDA-A&A+ Series

- 3) Check if the phase of U, V, W cables is connected correctly. Incorrect connection will cause the servo motor to rotate improperly.
- 4) When using an external resistor, connect it to P (P \oplus) and C, and ensure an open circuit between P (P \oplus) and D. When using an internal resistor, ensure the circuit is closed between P (P \oplus) and D, and the circuit is open between P (P \oplus) and C.
- 5) If a fault or emergency stop occurs, using ALARM or WARN output can control electromagnetic contactor and cut off the power of the servo drive.

Chapter 3 Connections and Wiring | ASDA-A&A+ Series

3.1.2 Servo Drive Connectors and Terminals

Terminal Identification	Terminal Description	Notes	
L1, L2	Control circuit terminal	The servo Control Circuit requires an independent 220V single-phase VAC supply.	
R, S, T	Main circuit terminal	The Main Circuit Terminal is used to supply the servo with line power. If a single-phase supply, is used connect the R and S terminals to power. If 3-phase, connect all three R, S, & T terminals. To provide Control Circuit power two jumpers can be added from R and S to L1 and L2.	
U, V, W FG	Servo motor output	Used to connect servo motor	
		Terminal Symbol	Wire Color
		U	Red
		V	White
		W	Black
FG	Green		
P (P⁺), D, C	Regenerative resistor terminal	Internal resistor	Ensure the circuit is closed between P(P ⁺) and D, and the circuit is open between P(P ⁺) and C.
		External resistor	Connect regenerative resistor to P(P ⁺) and C, and ensure an open circuit between P(P ⁺) and D.
P⁺, ⁻	P ⁺ : Main circuit (+) terminal ⁻ : Main circuit (-) terminal	Braking unit is suitable for 2kW and above models. When using braking unit, ensure to connect (+) terminal of the braking unit to P ⁺ , main circuit (+) terminal of the servo drive, and connect (-) terminal of the braking unit to ⁻ , main circuit (-) terminal of the servo drive. The braking unit is an optional part. Usually, the braking unit is not necessary. It is used to absorb the large regenerative power that is generated when the external load is much greater than the motor torque.	
 two places	Ground terminal	Used to connect grounding wire of power supply and servo motor.	
CN1	I/O connector	Used to connect external controllers. Please refer to section 3.3 for details.	
CN2	Encoder connector	Used to connect encoder of servo motor. Please refer to section 3.4 for details.	
		ASDA-A Series	
		Terminal Symbol	Wire Color
		A	Blue
		/A	Blue/Black
		B	Green
		/B	Green/Black
		Z	Yellow
		/Z	Yellow/Black
		+5V	Red
GND	Black		

Chapter 3 Connections and Wiring | ASDA-A&A+ Series

Terminal Identification	Terminal Description	Notes	
CN2	Encoder connector	ASDA-A+ Series	
		Terminal Symbol	Wire Color
		Line driver SD	Blue
		Line driver /SD	Blue/Black
		Vcc	Red
		GND	Black
CN3	Communication connector	Used to connect PC or keypad. Please refer to section 3.5 for details.	

 **NOTE**

- 1) U, V, W, CN1, CN2, CN3 terminals provide short circuit protection.

Wiring Notes

Please observe the following wiring notes while performing wiring and touching any electrical connections on the servo drive or servo motor.

1. Ensure to check if the power supply and wiring of the "power" terminals (R, S, T, U, V, & W) is correct.
2. Please use shielded twisted-pair cables for wiring to prevent voltage coupling and eliminate electrical noise and interference.
3. As a residual hazardous voltage may remain inside the drive, please do not immediately touch any of the "power" terminals (R, S, T, U, V, & W) and/or the cables connected to them after the power has been turned off and the charge LED is lit. (Please refer to the Safety Precautions on page ii).
4. The cables connected to R, S, T and U, V, W terminals should be placed in separate conduits from the encoder or other signal cables. Separate them by at least 30cm (11.8 inches).
5. If the encoder cable is too short, please use a twisted-shield signal wire with grounding conductor. The wire length should be 20m (65.62ft.) or less. For lengths greater than 20m (65.62ft.), the wire gauge should be doubled in order to lessen any signal attenuation.
6. As for motor cable selection, please use the 600V PTFE wire and the wire length should be less than 98.4ft. (30m). If the wiring distance is longer than 30m (98.4ft.), please choose the adequate wire size according to the voltage.
7. The shield of shielded twisted-pair cables should be connected to the SHIELD end (terminal marked ) of the servo drive.
8. For the connectors and cables specifications, please refer to section 3.1.6 for details.

Chapter 3 Connections and Wiring | ASDA-A&A+ Series

3.1.3 Wiring Methods

For servo drives from 100W to 1.5kW the input power can be either single or three-phase. For servo drives 2kW and above only three-phase connections are available.

In the wiring diagram figures 3.3 & 3.4:

Power ON : contact “a” (normally open)

Power OFF or Alarm Processing : contact “b” (normally closed)

MC : coil of electromagnetic contactor, self-holding power, contact of main circuit power

Figure 3.3 Single-Phase Power Supply Connection (for 1.5kW and below models)

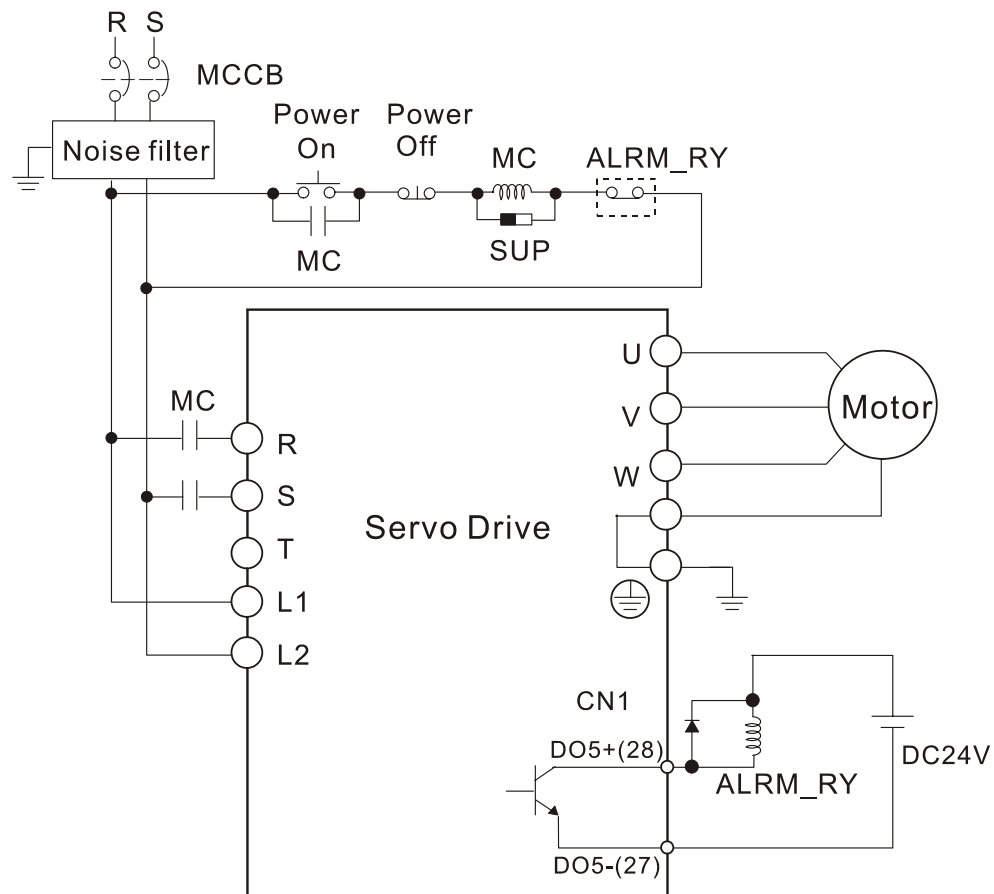

Chapter 3 Connections and Wiring | ASDA-A&A+ Series

Figure 3.4 Three-Phase Power Supply Connection (for all models)

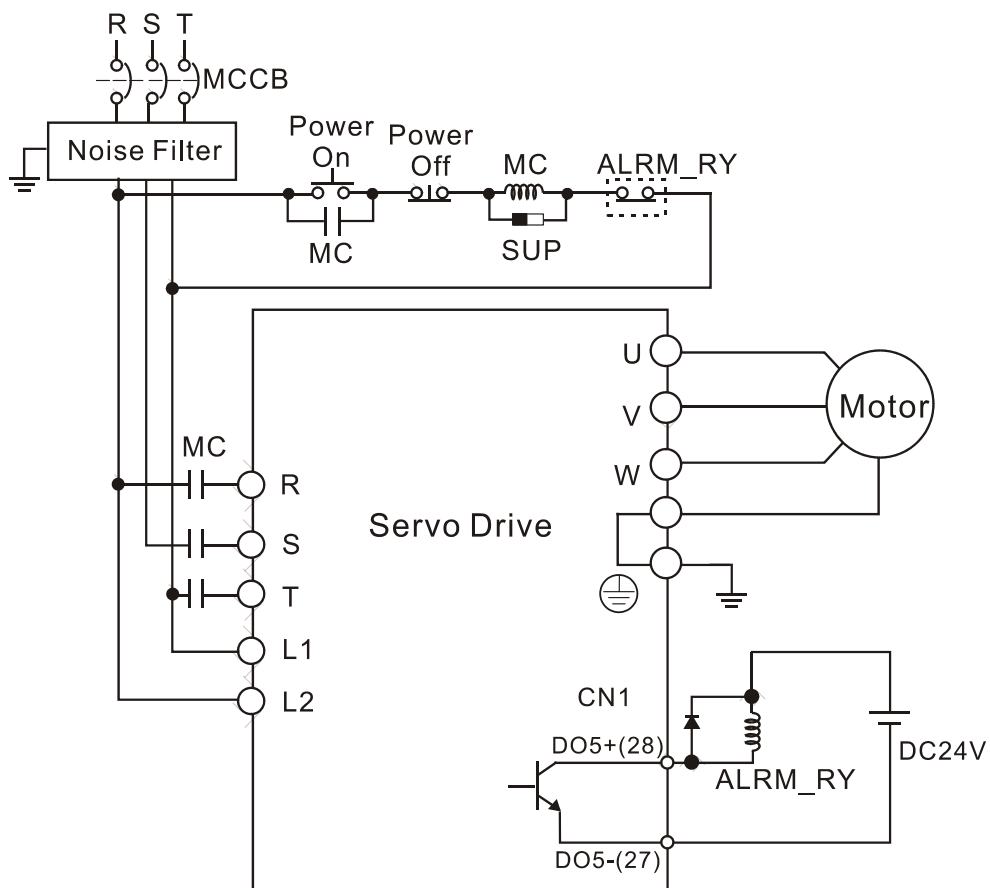

Chapter 3 Connections and Wiring | ASDA-A&A+ Series

3.1.4 Motor Power Cable Connector Specifications

The boxes (□) in the model names are for optional configurations. (Please refer to section 1.2 for model explanation.)

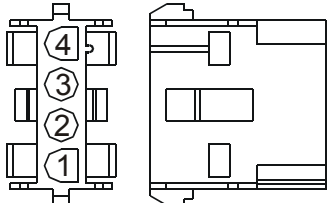
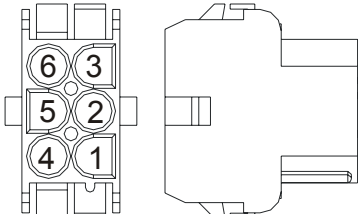
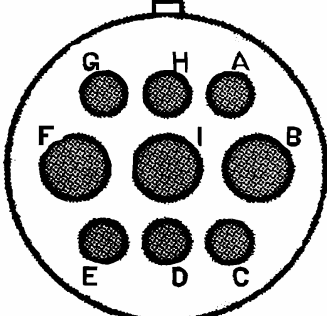
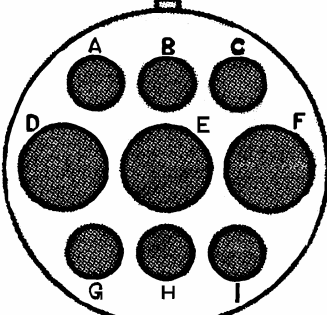
Servo Drive Power Rating	Motor Part Number Description	U, V, W / Electromagnetic Brake Connector	Terminal Identification
100W	ASMT-01L250A□		A
200W	ASMT-02L250A□		
400W	ASMT-04L250A□		
750W	ASMT-07L250A□		
100W	ASMT-01L250B□		B
200W	ASMT-02L250B□		
400W	ASMT-04L250B□		
750W	ASMT-07L250B□		
1kW	ASMT-10L250□□	 <p style="text-align: center;">20-18</p>	C
	ASMT-10M250□□		
1.5kW	ASMT-15M250□□		
2kW	ASMT-20L250□□		
3kW	ASMT-30L250□□		
2kW	ASMT-20M250□□	 <p style="text-align: center;">24-11</p>	D
	3kW		
4.5kW	ECMA-F21830□S		
	ECMA-E21835□S		
	ECMA-F21845□S		

Terminal Identification	U (Red)	V (White)	W (Black)	CASE GROUND (Green)	BRAKE1 (Blue)	BRAKE2 (Brown)
A	1	2	3	4	-	-
B	1	2	3	4	5	6
C	F	I	B	E	G	H
D	D	E	F	G	A	B

Chapter 3 Connections and Wiring | ASDA-A&A+ Series

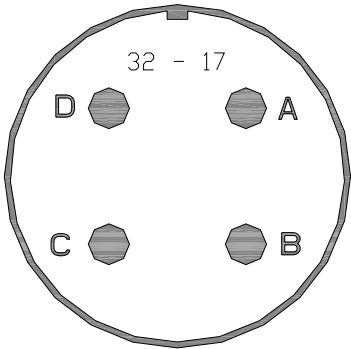
Servo Drive Power Rating	Motor Part Number Description	U, V, W Connector	Terminal Identification
5.5kW	ECMA-F21855□3		E
7.5kW	ECMA-F21875□3		

Terminal Identification	U	V	W	CASE GROUND
E	A	B	C	D

Servo Drive Power Rating	Motor Part Number Description	Electromagnetic Brake Connector	Terminal Identification
5.5kW	ECMA-F21855□3		F
7.5kW	ECMA-F21875□3		

Terminal Identification	BRAKE1	BRAKE2
F	A	B

Chapter 3 Connections and Wiring | ASDA-A&A+ Series

3.1.5 Encoder Connector Specifications

The boxes (□) in the model names are for optional configurations. (Please refer to section 1.2 for model explanation.)

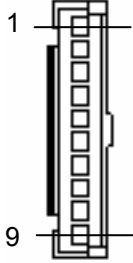
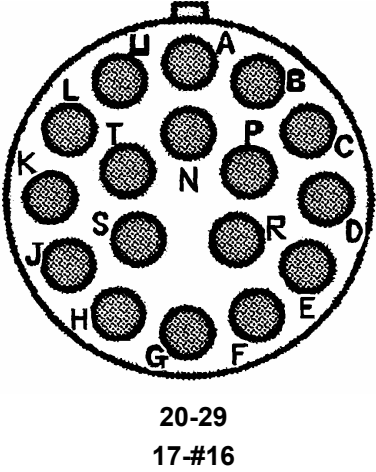
Servo Drive Capacity	Motor Model Name	Encoder Connector	Terminal Identification
100W	ASMT-01L250□□		A
200W	ASMT-02L250□□		
400W	ASMT-04L250□□		
750W	ASMT-07L250□□		
1kW	ASMT-10L250□□		B
	ASMT-10M250□□		
1.5kW	ASMT-15M250□□		
2kW	ASMT-20L250□□		
	ASMT-20M250□□		
3kW	ASMT-30L250□□		
	ASMT-30M250□□		
4.5kW	ECMA-F21830□S		
	ECMA-E21835□S		
	ECMA-F21845□S		
5.5kW	ECMA-F21855□3		
7.5kW	ECMA-F21875□3		

Terminal Identification	A (Blue)	/A (Blue/ Black)	B (Green)	/B (Green/ Black)	Z (Yellow)	/Z (Yellow/ Black)	5V (Red)	GND (Black)	BRAID SHELD
A	1	2	3	4	5	6	7	8	9
B	A	B	C	D	F	G	S	R	L

Chapter 3 Connections and Wiring | ASDA-A&A+ Series

3.1.6 Cable Specifications for Servo Drive

The boxes (□) in the model names are for optional configurations. (Please refer to section 1.2 for model explanation.)

ASDA-A Series

Power Cable

Servo Drive and Servo Motor		Power Cable - Wire Gauge mm ² (AWG)			
		L1, L2	R, S, T	U, V, W	P, C
ASD-A0121LA	ASMT01L250□□	1.3 (AWG16)	2.1 (AWG14)	2.1 (AWG14)	2.1 (AWG14)
ASD-A0221LA	ASMT02L250□□	1.3 (AWG16)	2.1 (AWG14)	2.1 (AWG14)	2.1 (AWG14)
ASD-A0421LA	ASMT04L250□□	1.3 (AWG16)	2.1 (AWG14)	2.1 (AWG14)	2.1 (AWG14)
ASD-A0721LA	ASMT07L250□□	1.3 (AWG16)	2.1 (AWG14)	2.1 (AWG14)	2.1 (AWG14)
ASD-A1021LA	ASMT10L250□□	1.3 (AWG16)	2.1 (AWG14)	2.1 (AWG14)	2.1 (AWG14)
ASD-A1021MA	ASMT20L250□□	1.3 (AWG16)	2.1 (AWG14)	2.1 (AWG14)	2.1 (AWG14)
ASD-A1521MA	ASMT30L250□□	1.3 (AWG16)	2.1 (AWG14)	2.1 (AWG14)	2.1 (AWG14)
ASD-A2023LA	ASMT10M250□□	1.3 (AWG16)	2.1 (AWG14)	2.1 (AWG14)	3.3 (AWG12)
ASD-A2023MA	ASMT15M250□□	1.3 (AWG16)	2.1 (AWG14)	2.1 (AWG14)	3.3 (AWG12)
ASD-A3023LA	ASMT20M250□□	1.3 (AWG16)	3.3 (AWG12)	3.3 (AWG12)	3.3 (AWG12)
ASD-A3023MA	ASMT30M250□□	1.3 (AWG16)	3.3 (AWG12)	3.3 (AWG12)	3.3 (AWG12)

Encoder Cable

Servo Drive	Encoder Cable - Wire Gauge mm ² (AWG)			
	Wire Size	Core Number	UL Rating	Wire Length
ASD-A0121LA	0.13 (AWG26)	10 core (4 pair)	UL2464	3m (9.84ft.)
ASD-A0221LA	0.13 (AWG26)	10 core (4 pair)	UL2464	3m (9.84ft.)
ASD-A0421LA	0.13 (AWG26)	10 core (4 pair)	UL2464	3m (9.84ft.)
ASD-A0721LA	0.13 (AWG26)	10 core (4 pair)	UL2464	3m (9.84ft.)
ASD-A1021LA	0.13 (AWG26)	10 core (4 pair)	UL2464	3m (9.84ft.)
ASD-A1021MA	0.13 (AWG26)	10 core (4 pair)	UL2464	3m (9.84ft.)
ASD-A1521MA	0.13 (AWG26)	10 core (4 pair)	UL2464	3m (9.84ft.)
ASD-A2023LA	0.13 (AWG26)	10 core (4 pair)	UL2464	3m (9.84ft.)
ASD-A2023MA	0.13 (AWG26)	10 core (4 pair)	UL2464	3m (9.84ft.)
ASD-A3023LA	0.13 (AWG26)	10 core (4 pair)	UL2464	3m (9.84ft.)
ASD-A3023MA	0.13 (AWG26)	10 core (4 pair)	UL2464	3m (9.84ft.)

Chapter 3 Connections and Wiring | ASDA-A&A+ Series

ASDA-A+ Series

Power Cable

Servo Drive and Servo Motor		Power Cable - Wire Gauge mm ² (AWG)			
		L1, L2	R, S, T	U, V, W	P, C
ASD-A4523-B	ECMA-F21830□S	1.3 (AWG16)	3.3 (AWG12)	3.3 (AWG12)	3.3 (AWG12)
	ECMA-E21835□S	1.3 (AWG16)	3.3 (AWG12)	3.3 (AWG12)	3.3 (AWG12)
	ECMA-F21845□S	1.3 (AWG16)	3.3 (AWG12)	8.4 (AWG8)	3.3 (AWG12)
ASD-A5523-B	ECMA-F21855□3	1.3 (AWG16)	3.3 (AWG12)	13.3 (AWG6)	3.3 (AWG12)
ASD-A7523-B	ECMA-F21875□3	1.3 (AWG16)	5.3 (AWG10)	13.3 (AWG6)	3.3 (AWG12)

Encoder Cable

Servo Drive	Encoder Cable - Wire Gauge mm ² (AWG)			
	Wire Size	Core Number	UL Rating	Wire Length
ASD-A4523-B	0.13 (AWG26)	10 core (4 pair)	UL2464	3m (9.84ft.)
ASD-A5523-B	0.13 (AWG26)	10 core (4 pair)	UL2464	3m (9.84 ft.)
ASD-A7523-B	0.13 (AWG26)	10 core (4 pair)	UL2464	3m (9.84 ft.)

NOTE

- 1) Please use shielded twisted-pair cables for wiring to prevent voltage coupling and eliminate electrical noise and interference.
- 2) The shield of shielded twisted-pair cables should be connected to the SHIELD end (terminal marked ⊕) of the servo drive.
- 3) In order to prevent fire hazard and accidents, please form the wiring by following the cable specifications outlined above.

Chapter 3 Connections and Wiring | ASDA-A&A+ Series

3.2 Basic Wiring

Figure 3.5 Basic Wiring Schematic of 100W ~ 1.5kW models

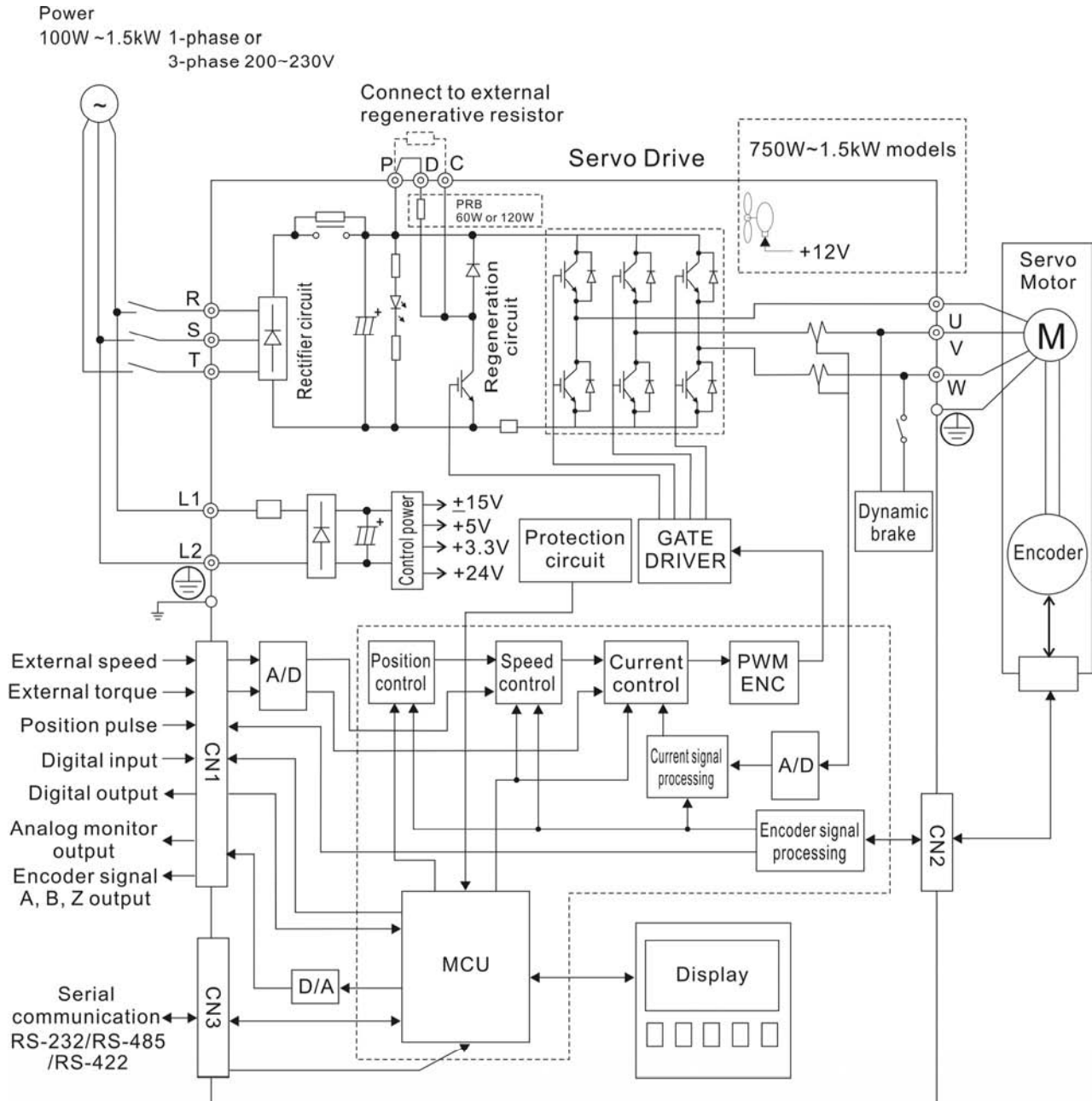

Chapter 3 Connections and Wiring | ASDA-A&A+ Series

Figure 3.6 Basic Wiring Schematic of 2kW ~ 3kW models

Power
2kW ~ 3kW 3-phase 200~230V

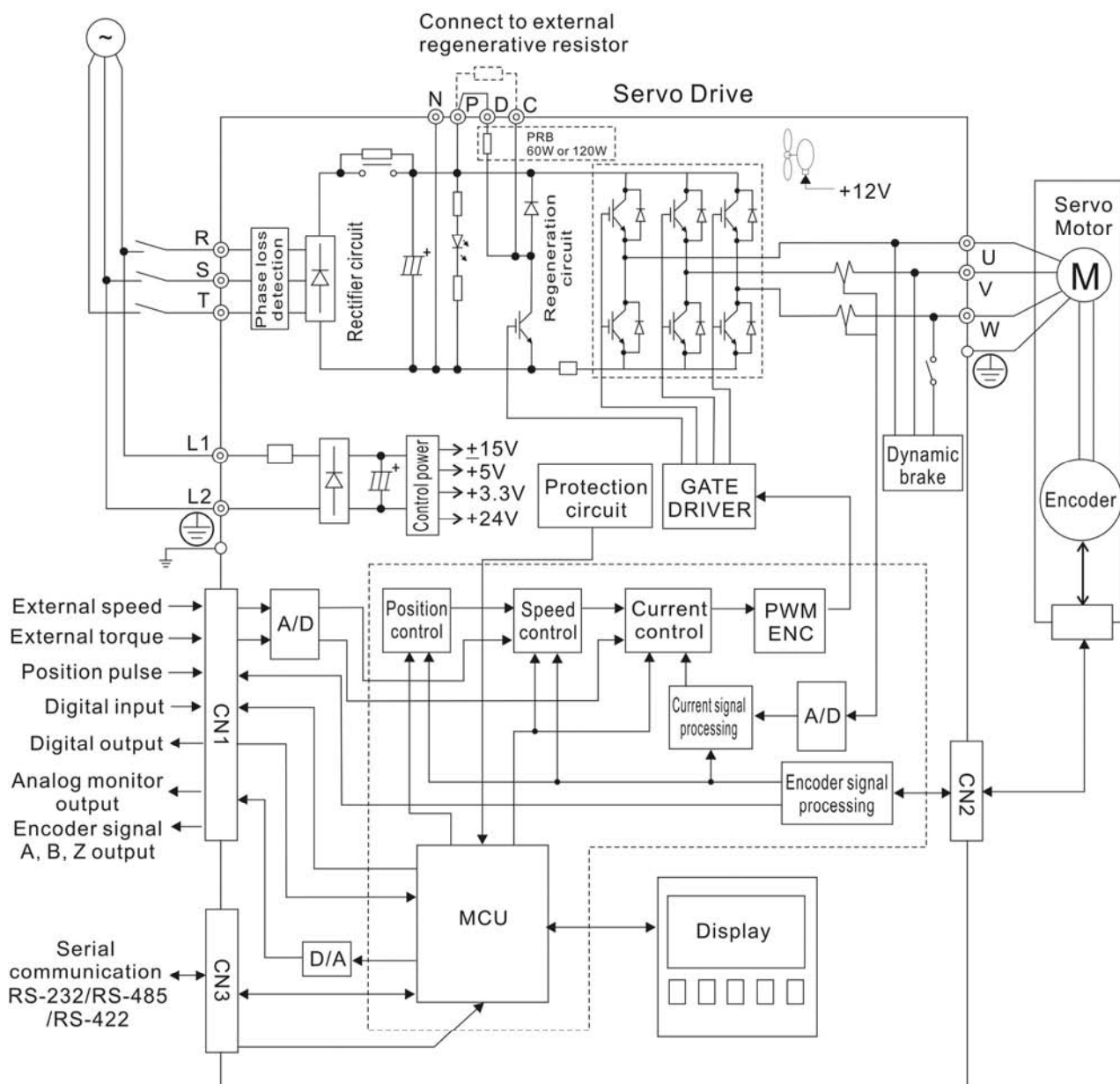

Chapter 3 Connections and Wiring | ASDA-A&A+ Series

Figure 3.7 Basic Wiring Schematic of 4.5kW model

Power
4.5kW 3-phase 200~230V

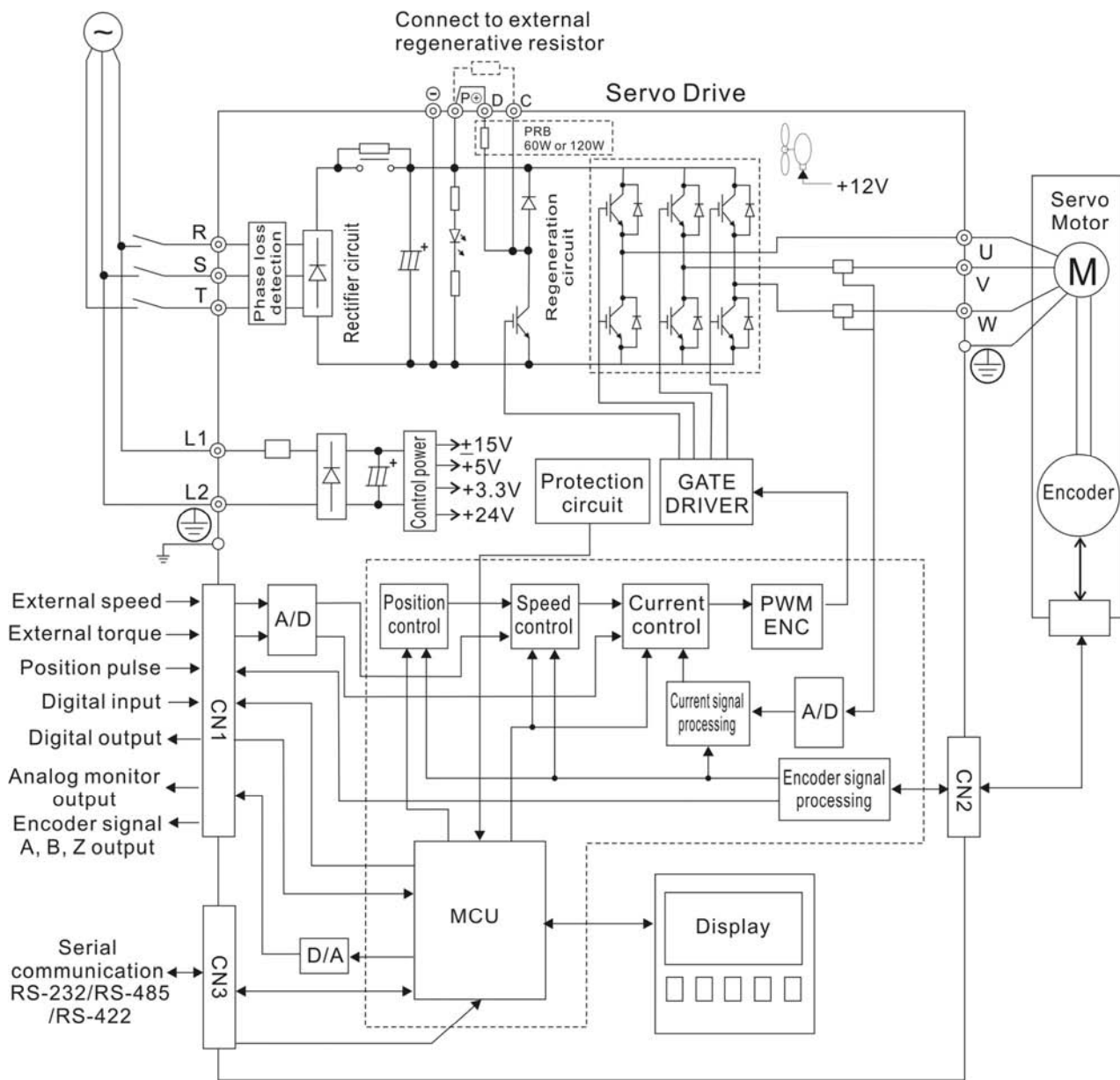

Chapter 3 Connections and Wiring | ASDA-A&A+ Series

Figure 3.8 Basic Wiring Schematic of 5.5kW ~ 7.5kW models

Power
5.5kW ~ 7.5kW 3-phase 200~230V

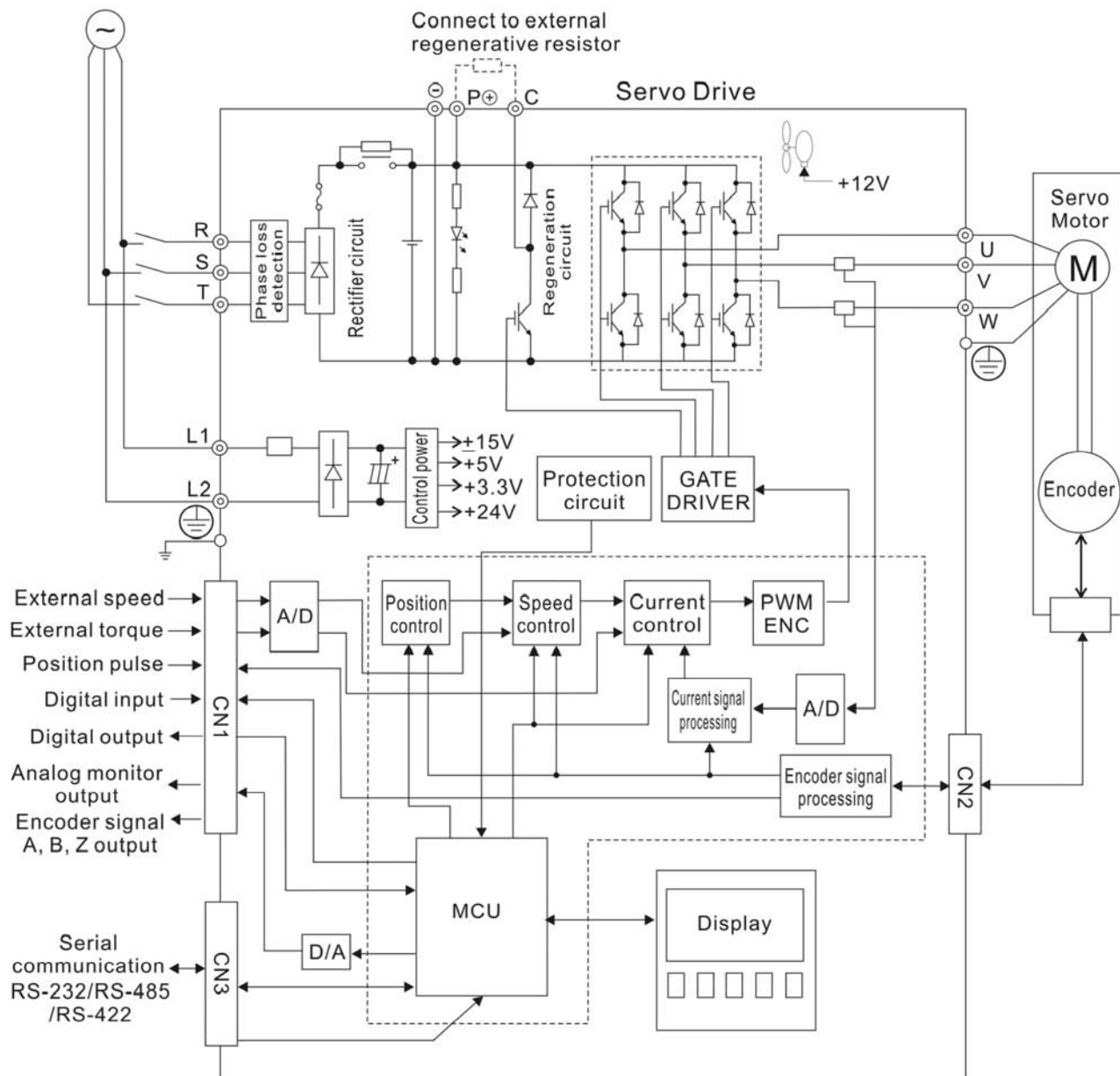

Chapter 3 Connections and Wiring | ASDA-A&A+ Series**CN1 Terminal Signal Identification**

2	DO3-	Digital output	1	DO4+	Digital output	27	DO5-	Digital output	26	DO4-	Digital output
4	DO2-	Digital output	3	DO3+	Digital output	29	/HPULSE	High-speed Pulse input (-)	28	DO5+	Digital output
6	DO1-	Digital output	5	DO2+	Digital output	31	DI7-	Digital input	30	DI8-	Digital input
8	DI4-	Digital input	7	DO1+	Digital output	33	DI5-	Digital input	32	DI6-	Digital input
10	DI2-	Digital input	9	DI1-	Digital input	35	PULL HI	Pulse applied power	34	DI3-	Digital input
12	GND	Analog input signal ground	11	COM+	Power input (12~24V)	37	SIGN	Position sign (+)	36	/SIGN	Position sign (-)
14	NC	No Connection	13	GND	Analog input signal ground	39	NC	No Connection	38	HPULSE	High-speed Pulse input (+)
16	MON1	Analog monitor output 1	15	MON2	Analog monitor output 2	41	PULSE	Pulse input (+)	40	/HSIGN	High-speed position sign (-)
18	T_REF	Analog torque Input	17	VDD	+24V power output (for external I/O)	43	/PULSE	Pulse input (-)	42	V_REF	Analog speed input (+)
20	VCC	+12V power output (for analog command)	19	GND	Analog input signal ground	45	COM-	VDD(24V) power ground	44	GND	Analog input signal ground
22	/OA	Encoder /A pulse output	21	OA	Encoder A pulse output	47	COM-	VDD(24V) power ground	46	HSIGN	High-speed position sign (+)
24	/OZ	Encoder /Z pulse output	23	/OB	Encoder /B pulse output	49	COM-	VDD(24V) power ground	48	OCZ	Encoder Z pulse Open-collector output
			25	OB	Encoder B pulse output				50	OZ	Encoder Z pulse Line-driver output

NOTE

- 1) CN1 terminal signal, HSIGN (pin 46), /HSIGN (pin 40), HPULSE (pin 38), and /HPULSE (pin 29) are provided in ASDA-A+ series only. In ASDA-A series, the function of these terminals is "NC", which means "No Connection".
- 2) The terminals marked "NC" must be left unconnected (No Connection). The NC terminals are used within the servo drive. Any outside connection to the NC terminals will result in damage to the drive and void the warranty!

Chapter 3 Connections and Wiring | ASDA-A&A+ Series

3.3.2 Signals Explanation of Connector CN1

The Tables 3.A, 3.B, & 3.C detail the three groups of signals of the CN1 interface. Table 3.A details the general signals. Table 3.B details the Digital Output (DO) signals and Table 3.C details the Digital Input (DI) signals. The General Signals are set by the factory and can not be changed, reprogrammed or adjusted. Both the Digital Input and Digital Output signals can be programmed by the users.

Table 3.A General Signals

Signal		Pin No	Details	Wiring Diagram (Refer to 3.3.4)
Analog Signal Input	V_REF	42	Motor speed command: -10V to +10V, corresponds to the maximum speed programmed P1-55 Maximum Speed Limit (Factory default 3000 r/min).	C1
	T_REF	18	Motor torque command: -10V to +10V, corresponds to -100% to +100% rated torque command.	C1
Analog Monitor Output	MON1	16	The MON1 and MON2 can be assigned drive and motor parameters that can be monitored via an analogue voltage. Please reference parameter P0-03 for monitoring commands and P1-04 / P1-05 for scaling factors. Output voltage is reference to the power ground.	C2
	MON2	15		
Position Pulse Input	PULSE	41	The drive can accept two different types of pulse inputs: Open Collector and Line Driver. Three different pulse commands can be selected via parameter P1-00. Quadrature, CW + CCW pulse & Pulse / Direction.	C3/C4-1
	/PULSE	43		
	SIGN	37		
	/SIGN	36		
	PULL HI	35	Should an Open Collector type of pulse be used this terminal must be lull high to pin 17.	C3
High- speed Position Pulse Input	HSIGN	46	The drive can accept two different types of pulse inputs: Open Collector and Line Driver. Three different pulse commands can be selected via parameter P1-00. Quadrature, CW + CCW pulse & Pulse / Direction. These signals are used for ASDA-A+ series only. In ASDA-A series, these terminals are marked "NC", which means "No Connection" and must be left unconnected.	C4-2
	/HSIGN	40		
	HPULSE	38		
	/HPULSE	29		
Position Pulse Output	OA	21	The motor encoder signals are available through these terminals. The encoder output pulse count can be set via parameter P1-46.	C11/C12
	/OA	22		
	OB	25		
	/OB	23		
	OZ	50		
	/OZ	24		
Power	VDD	17	VDD is the +24V source voltage provided by the drive. Maximum permissible current 500mA.	-
	COM+	11	COM+ is the common voltage rail of the Digital Input and Digital Output signals. Connect VDD to COM+ for source mode. For external applied power sink mode (+12V to +24V), the positive terminal should be connected to COM+ and the negative to COM-.	
		45		
		47		
COM-	49			

Chapter 3 Connections and Wiring | ASDA-A&A+ Series

Signal		Pin No	Details	Wiring Diagram (Refer to 3.3.4)
Power	VCC	20	VCC is a +12V power rail provided by the drive. It can be used for the input on an analog speed or torque command. Maximum permissible current 100mA.	-
	GND	12,13, 19,44	The polarity of VCC is with respect to Ground (GND).	
Other	NC	14,29, 38,39, 40,46, 48	See previous note for NC terminals CN1 connector on page 3-15.	-

The Digital Input (DI) and Digital Output (DO) have factory default settings which correspond to the various servo drive control modes. (See section 1.5). However, both the DI's and DO's can be programmed independently to meet the requirements of the users.

Detailed in Tables 3.B and 3.C are the DO and DI functions with their corresponding signal name and wiring schematic. The factory default settings of the DI and DO signals are detailed in Table 3.G and 3.H.

All of the DI's and DO's and their corresponding pin numbers are factory set and non-changeable, however, all of the assigned signals and control modes are user changeable. For Example, the factory default setting of DO5 (pins 28/27) can be assigned to DO1 (pins 7/6) and vice versa.

The following Tables 3.B and 3.C detail the functions, applicable operational modes, signal name and relevant wiring schematic of the default DI and DO signals.

Table 3.B DO Signals

DO Signal	DO Code	Assigned Control Mode	Pin No. (Default)		Details ^(*)	Wiring Diagram (Refer to 3.3.4)
			+	-		
SRDY	01	ALL	7	6	SRDY is activated when the servo drive is ready to run. All fault and alarm conditions, if present, have been cleared.	C5/C6/C7/C8
SON	02	Not assigned	-	-	SON is activated when control power is applied the servo drive. The drive may or may not be ready to run as a fault / alarm condition may exist. Servo ON (SON) is "ON" with control power applied to the servo drive, there may be a fault condition or not. The servo is not ready to run. Servo ready (SRDY) is "ON" where the servo is ready to run, NO fault / alarm exists. (P2-51 should turn servo ready SRDY off / on)	

Chapter 3 Connections and Wiring | ASDA-A&A+ Series

DO Signal	DO Code	Assigned Control Mode	Pin No. (Default)		Details ^(*)	Wiring Diagram (Refer to 3.3.4)
			+	-		
ZSPD	03	ALL	5	4	ZSPD is activated when the drive senses the motor is equal to or below the Zero Speed Range setting as defined in parameter P1-38. For Example, at factory default ZSPD will be activated when the drive detects the motor rotating at speed at or below 10 r/min. ZSPD will remain activated until the motor speed increases above 10 r/min.	C5/C6/C7/C8
TSPD	04	ALL (except Pt, Pr)	-	-	TSPD is activated once the drive has detected the motor has reached the Target Rotation Speed setting as defined in parameter P1-39. TSPD will remain activated until the motor speed drops below the Target Rotation Speed.	
TPOS	05	Pt, Pr, Pt-S, Pt-T, Pr-S, Pr-T	1	26	1. When the drive is in Pt mode, TPOS will be activated when the position error is equal and below the setting value of P1-54. 2. When the drive is in Pr mode, TPOS will be activated when the drive detects that the position of the motor is in a -P1-54 to +P1-54 band of the target position. For Example, at factory default TPOS will activate once the motor is in -99 pulses range of the target position, then deactivate after it reaches +99 pulses range of the desired position.	
TQL	06	Not assigned	-	-	TQL is activated when the drive has detected that the motor has reached the torques limits set by either the parameters P1-12 ~ P1-14 of via an external analog voltage.	
ALRM	07	ALL	28	27	ALRM is activated when the drive has detected a fault condition. (However, when Reverse limit error, Forward limit error, Emergency stop, Serial communication error, and Undervoltage these fault occur, WARN is activated first.)	
BRKR	08	ALL			BRKR is activated actuation of motor brake.	
HOME	09	ALL	3	2	HOME is activated when the servo drive has detected that the "HOME" sensor (Digital Input 24) has been detected and the home conditions set in parameters P1-47, P1-50, and P1-51 have been satisfied.	
OLW	10	ALL	-	-	OLW is activated when the servo drive has detected that the motor has reached the output overload level set by the parameter P1-56.	
WARN	11	ALL	-	-	Servo warning activated. WARN is activated when the drive has detected Reverse limit error, Forward limit error, Emergency stop, Serial communication error, and Undervoltage these fault conditions.	

Chapter 3 Connections and Wiring | ASDA-A&A+ Series

DO Signal	DO Code	Assigned Control Mode	Pin No. (Default)		Details ^(*)	Wiring Diagram (Refer to 3.3.4)
			+	-		
CMDOK	12	Pr			Internal position command completed output. CMDOK is activated when the servo drive has detected that the internal position command has been completed or stopped after the delay time which is set by the parameter P1-62 has elapsed.	C5/C6/C7/C8

Footnote *1: The "state" of the output function may be turned ON or OFF as it will be dependant on the settings of P2-18~P2-22.

 **NOTE**

- 1) PINS 3 & 2 can either be TSPD or HOME dependent upon control mode selected.
- 2) PINS 1 & 26 are different depending on control mode either BRKR or TPOS.

Table 3.C DI Signals

DI Signal	DI Code	Assigned Control Mode	Pin No. (Default)	Details ^(*)	Wiring Diagram (Refer to 3.3.4)
SON	01	ALL	9	Servo On. Switch servo to "Servo Ready". Check parameter P2-51.	C9/C10
ARST	02	ALL	33	A number of Faults (Alarms) can be cleared by activating ARST. Please see table 10-3 for applicable faults that can be cleared with the ARST command. However, please investigate Fault or Alarm if it does not clear or the fault description warrants closer inspection of the drive system.	
GAINUP	03	ALL	-	Gain switching in speed and position mode	
CCLR	04	Pt, Pr	10	When CCLR is activated the setting is parameter P2-50 Pulse Clear Mode is executed.	
ZCLAMP	05	ALL	-	When this signal is On and the motor speed value is lower than the setting value of P1-38, it is used to lock the motor in the instant position while ZCLAMP is On.	
CMDINV	06	Pr, T, S	-	When this signal is On, the motor is in reverse rotation.	
HOLD	07	Not assigned		Internal position control command pause	
CTRG	08	Pr, Pr-S, Pr-T	10	When the drive is in Pr mode and CTRG is activated, the drive will command the motor to move the stored position which correspond the POS 0, POS 1, POS 2 settings. Activation is triggered on the rising edge of the pulse.	

Chapter 3 Connections and Wiring | ASDA-A&A+ Series

DI Signal	DI Code	Assigned Control Mode	Pin No. (Default)	Details ^{(*)2}	Wiring Diagram (Refer to 3.3.4)
TRQLM	09	S, Sz	10	ON indicates the torque limit command is valid.	C9/C10
SPDLM	10	T, Tz	10	ON indicates the speed limit command is valid.	
POS0	11	Pr, Pr-S, Pr-T	34	When the Pr Control Mode is selected the 8 stored positions are programmed via a combination of the POS 0, POS 1, and POS 2 commands. See table 3.D.	
POS1	12		8		
POS2	13		-		
SPD0	14	S, Sz, Pt-S, Pr-S, S-T	34	Select the source of speed command:	
SPD1	15		8	See table 3.E.	
TCM0	16	Pt, T, Tz, Pt-T, Pr-T, S-T	34	Select the source of torque command:	
TCM1	17		8	See table 3.F.	
S-P	18	Pt-S, Pr-S	31	Speed / Position mode switching OFF: Speed, ON: Position	
S-T	19	S-T	31	Speed / Torque mode switching OFF: Speed, ON: Torque	
T-P	20	Pt-T, Pr-T	31	Torque / Position mode switching OFF: Torque, ON: Position	
EMGS	21	ALL	30	It should be contact "b" and normally ON or a fault (ALE13) will display.	
CWL	22	Pt, Pr, S, T Sz, Tz	32	Reverse inhibit limit. It should be contact "b" and normally ON or a fault (ALE14) will display.	
CCWL	23	Pt, Pr, S, T Sz, Tz	31	Forward inhibit limit. It should be contact "b" and normally ON or a fault (ALE15) will display.	
ORGP	24	Pr	-	When ORGP is activated, the drive will command the motor to start to search the reference "Home" sensor.	
TLLM	25	Not assigned	-	Torque limit - Reverse operation (Torque limit function is valid only when P1-02 is enabled)	
TRLM	26	Not assigned	-	Torque limit - Forward operation (Torque limit function is valid only when P1-02 is enabled)	
SHOM	27	Pr	-	When SHOM is activated, the drive will command the motor to move to "Home". (Refer to Pr.1-47)	
INDEX0	28	Pr	-	Feed step selection input 0 ~ 4 (bit 0 ~ 4). When the drive is in Pr mode, if users set P1-33 to 2, 3 and 4 (Feed step control mode), feed step control function are provided (1~32 steps). [see section 12.6 Feed Step Control]	
INDEX1	29	Pr	-		
INDEX2	30	Pr	-		
INDEX3	31	Pr	-		
INDEX4	32	Pr	-		

Chapter 3 Connections and Wiring | ASDA-A&A+ Series

DI Signal	DI Code	Assigned Control Mode	Pin No. (Default)	Details ^{(*)2}	Wiring Diagram (Refer to 3.3.4)
MD0	33	Pr	-	Feed step mode input 0 (bit 0)	C9/C10
MD1	34	Pr	-	Feed step mode input 1 (bit 1)	
MDP0	35	Pr	-	Manually continuous operation	
MDP1	36	Pr	-	Manually single step operation	
JOGU	37	ALL	-	Forward JOG input. When JOGU is activated, the motor will JOG in forward direction. [see P4-05]	
JOGD	38	ALL	-	Reverse JOG input. When JOGD is activated, the motor will JOG in reverse direction. [see P4-05]	
STEPU	39	Pr	-	Step up input. When STEPU is activated, the motor will run to next position.	
STEPD	40	Pr	-	Step down input. When STEPD is activated, the motor will run to previous position.	
STEPB	41	Pr	-	Step back input. When STEPB is activated, the motor will return to first position.	
AUTOR	42	Pr	-	Auto run input. When AUTOR is activated, the motor will run automatically according to internal position command. For time interval setting, please see P2-52 to P2-59.	
GNUM0	43	Pt, Pr, Pt-S, Pr-S	-	Electronic gear ratio (Numerator) selection 0 [See P2-60~P2-62]	
GNUM1	44	Pt, Pr, Pt-S, Pr-S	-	Electronic gear ratio (Numerator) selection 1 [See P2-60~P2-62]	
INHP	45	Pt, Pt-S	-	Pulse inhibit input. When the drive is in position mode, if INHP is activated, the external pulse input command is not valid.	
STF	46	S, Sz, Pt-S, Pr-S, S-T	-	Enable motor forward operation. In speed mode, it is used to enable the motor forward operation.	
STB	47	S, Sz, Pt-S, Pr-S, S-T	-	Enable motor reverse operation. In speed mode, it is used to enable the motor reverse operation.	

Footnote *2: The "state" of the input function may be turned ON or OFF as it will be dependant on the settings of P2-10~P2-17.

Chapter 3 Connections and Wiring | ASDA-A&A+ Series**Table 3.D Source of Position Command**

POS2	POS1	POS0	Parameter
OFF	OFF	OFF	P1-15, P1-16
OFF	OFF	ON	P1-17, P1-18
OFF	ON	OFF	P1-19, P1-20
OFF	ON	ON	P1-21, P1-22
ON	OFF	OFF	P1-23, P1-24
ON	OFF	ON	P1-25, P1-26
ON	ON	OFF	P1-27, P1-28
ON	ON	ON	P1-29, P1-30

Table 3.E Source of Speed Command

SPD1	SPD0	Parameter
OFF	OFF	S mode: analog input Sz mode: 0
OFF	ON	P1-09
ON	OFF	P1-10
ON	ON	P1-11

Table 3.F Source of Torque Command

TCM1	TCM0	Parameter
OFF	OFF	T mode: analog input Tz mode: 0
OFF	ON	P1-12
ON	OFF	P1-13
ON	ON	P1-14

The default DI and DO signals in different control mode are listed in the following table 3.G and table 3.H. Although the content of the table 3.G and table 3.H do not provide more information than the table 3.B and table 3.C above, as each control mode is separated and listed in different row, it is easy for user to view and can avoid confusion. However, the Pin number of each signal can not be displayed in the table 3.G and table 3.H.

Chapter 3 Connections and Wiring | ASDA-A&A+ Series**Table 3.G Default DI signals and Control modes**

Signal	DI Code	Function	Pt	Pr	S	T	Sz	Tz	Pt-S	Pt-T	Pr-S	Pr-T	S-T
SON	01	Servo On	D11	D11	D11	D11	D11	D11	D11	D11	D11	D11	D11
ARST	02	Alarm Reset	D15	D15	D15	D15	D15	D15					
GAINUP	03	Gain switching in speed and position mode											
CCLR	04	Pulse clear (see P2-50)	D12						D12	D12			
ZCLAMP	05	Zero speed CLAMP											
CMDINV	06	Command input reverse control											
HOLD	07	Position command pause (Internal position control only)											
CTRG	08	Command triggered (available in Pr mode only)		D12							D12	D12	
TRQLM	09	Torque limit enabled			D12		D12						
SPDLM	10	Speed limit enabled				D12		D12					
POS0	11	Position command selection 0		D13							D13	D13	
POS1	12	Position command selection 1		D14							D14	D14	
POS2	13	Position command selection 2											
SPD0	14	Speed command selection 0			D13		D13		D13		D15		D13
SPD1	15	Speed command selection 1			D14		D14		D14		D16		D14
TCM0	16	Torque command selection 0	D13			D13		D13		D13		D15	D15
TCM1	17	Torque command selection 1	D14			D14		D14		D14		D16	D16
S-P	18	Position / Speed mode switching (OFF: Speed, ON: Position)							D17		D17		
S-T	19	Speed / Torque mode switching (OFF: Speed, ON: Torque)											D17
T-P	20	Torque / Position mode switching (OFF: Torque, ON: Position)								D17		D17	
EMGS	21	Emergency stop (contact b, normally closed)	D18	D18	D18	D18	D18	D18	D18	D18	D18	D18	D18
CWL	22	Reverse inhibit limit (contact b, normally closed)	D16	D16	D16	D16	D16	D16					

Chapter 3 Connections and Wiring | ASDA-A&A+ Series

Signal	DI Code	Function	Pt	Pr	S	T	Sz	Tz	Pt-S	Pt-T	Pr-S	Pr-T	S-T
CCWL	23	Forward inhibit limit (contact b, normally closed)	DI7	DI7	DI7	DI7	DI7	DI7					
ORGP	24	Reference "Home" sensor											
TLLM	25	Torque limit - Reverse operation (torque limit function is valid only when P1-02 is enabled)											
TRLM	26	Torque limit - Forward operation (torque limit function is valid only when P1-02 is enabled)											
SHOM	27	Move to "Home"											
INDEX0	28	Feed step selection input 0 (bit 0)											
INDEX1	29	Feed step selection input 1 (bit 1)											
INDEX2	30	Feed step selection input 2 (bit 2)											
INDEX3	31	Feed step selection input 3 (bit 3)											
INDEX4	32	Feed step selection input 4 (bit 4)											
MD0	33	Feed step mode input 0											
MD1	34	Feed step mode input 1											
MDP0	35	Manually continuous operation											
MDP1	36	Manually single step operation											
JOGU	37	Forward JOG input											
JOGD	38	Reverse JOG input											
STEPU	39	Step up input (available in Pr mode only)											
STEPD	40	Step down input (available in Pr mode only)											
STEPB	41	Step back input. (available in internal auto running mode only)											
AUTOR	42	Auto run input											
GNUM0	43	Electronic gear ratio (Numerator) selection 0 [see P2-60~P2-62]											
GNUM1	44	Electronic gear ratio (Numerator) selection 1 [see P2-60~P2-62]											

Chapter 3 Connections and Wiring | ASDA-A&A+ Series

Signal	DI Code	Function	Pt	Pr	S	T	Sz	Tz	Pt-S	Pt-T	Pr-S	Pr-T	S-T
INHP	45	Pulse inhibit input											
STF	46	Enable motor forward operation.											
STB	47	Enable motor reverse operation.											

 **NOTE**

- 1) For Pin numbers of DI1~DI8 signals, please refer to section 3.3.1.

Table 3.H Default DO signals and Control modes

Signal	DO Code	Function	Pt	Pr	S	T	Sz	Tz	Pt-S	Pt-T	Pr-S	Pr-T	S-T
SRDY	01	Servo ready	DO1	DO1	DO1	DO1	DO1	DO1	DO1	DO1	DO1	DO1	DO1
SON	02	Servo On											
ZSPD	03	At Zero speed	DO2	DO2	DO2	DO2	DO2	DO2	DO2	DO2	DO2	DO2	DO2
TSPD	04	At Speed reached			DO3	DO3	DO3	DO3	DO3	DO3	DO3	DO3	DO3
TPOS	05	At Positioning completed	DO4	DO4					DO4	DO4	DO4	DO4	DO4
TQL	06	At Torques limit											
ALRM	07	Servo alarm (Servo fault) activated	DO5	DO5	DO5	DO5	DO5	DO5	DO5	DO5	DO5	DO5	DO5
BRKR	08	Electromagnetic brake control			DO4	DO4	DO4	DO4					
HOME	09	Homing completed	DO3	DO3									
OLW	10	Output overload warning											
WARN	11	Servo warning activated											
CMDOK	12	Internal position command completed											

 **NOTE**

- 1) For Pin numbers of DO1~DO5 signals, please refer to section 3.3.1.

Chapter 3 Connections and Wiring | ASDA-A&A+ Series

3.3.3 User-defined DI and DO signals

If the default DI and DO signals could not be able to fulfill users' requirements, there are still user-defined DI and DO signals. The setting method is easy and they are all defined via parameters. The user-defined DI and DO signals are defined via parameters P2-10 to P2-17 and P2-18 to P2-22.

Please refer to the following Table 3.1 for the settings.

Table 3.1 User-defined DI and DO signals

Signal Name	Pin No.	Parameter	
DI	DI1-	9	P2-10
	DI2-	10	P2-11
	DI3-	34	P2-12
	DI4-	8	P2-13
	DI5-	33	P2-14
	DI6-	32	P2-15
	DI7-	31	P2-16
	DI8-	30	P2-17

Signal Name	Pin No.	Parameter	
DO	DO1+	7	P2-18
	DO1-	6	
	DO2+	5	P2-19
	DO2-	4	
	DO3+	3	P2-20
	DO3-	2	
	DO4+	1	P2-21
	DO4-	26	
	DO5+	28	P2-22
	DO5-	27	

DI signal:

For example: If the users want to set DI1 to be servo on, it only needs to set the value of parameter P2-10 to 101 (refer to chapter 7).

DO signal:

For example: If the users want to set DO1 to be servo ready, it only needs to set the value of parameter P2-18 to 101 (refer to chapter 7).

Chapter 3 Connections and Wiring | ASDA-A&A+ Series

C4-1: Pulse input (Line driver)

Because this photocoupler is a unidirectional optocoupler, please pay close attention on the current direction of input pulse command.

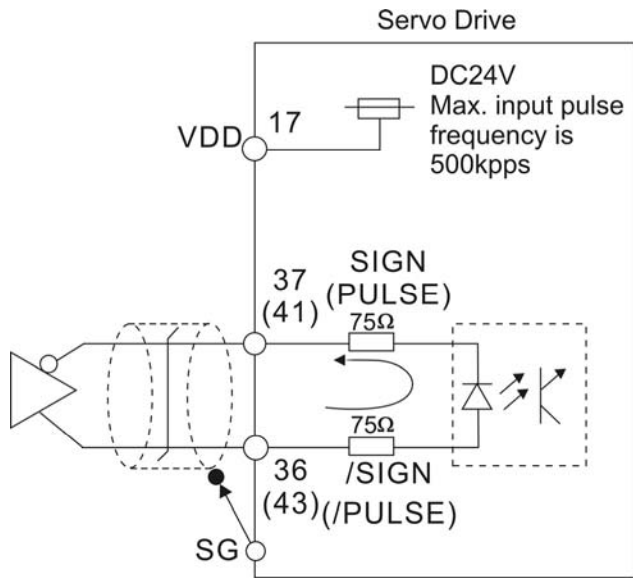

C4-2: High-speed pulse input (Line driver)

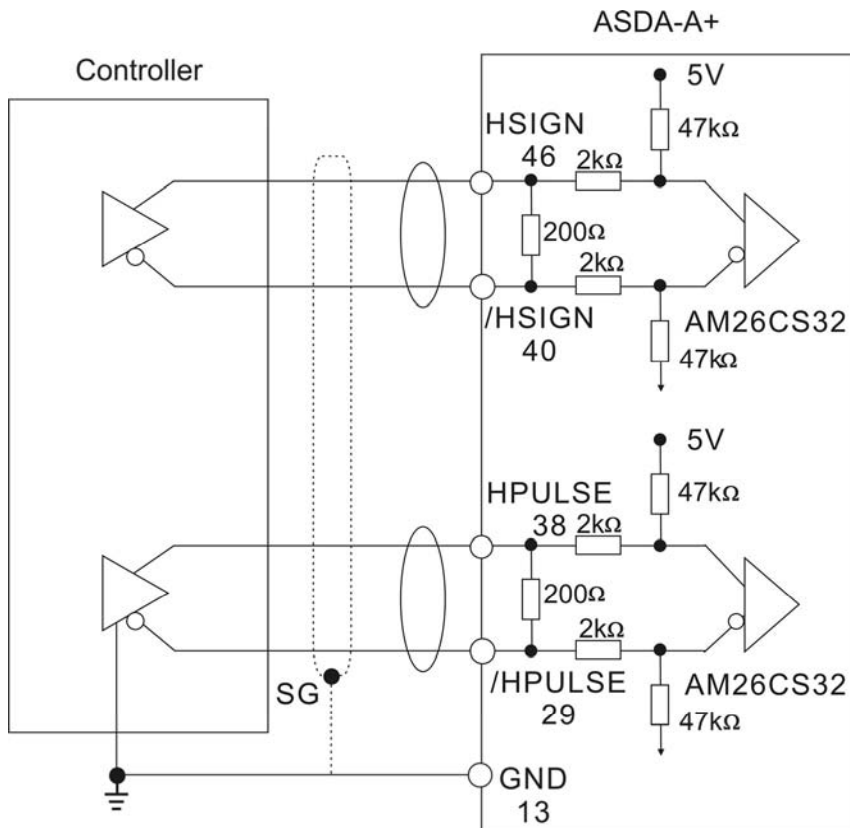

➤ **Caution:** Ensure that the ground terminal of the controller and the servo drive should be connected to each other.

Chapter 3 Connections and Wiring | ASDA-A&A+ Series

Be sure to connect a diode when the drive is applied to inductive load.

(Continuous maximum current: 40mA, Instantaneous peak current: max. 100mA)

C5: Wiring of DO signal, for the use of internal power supply, general load

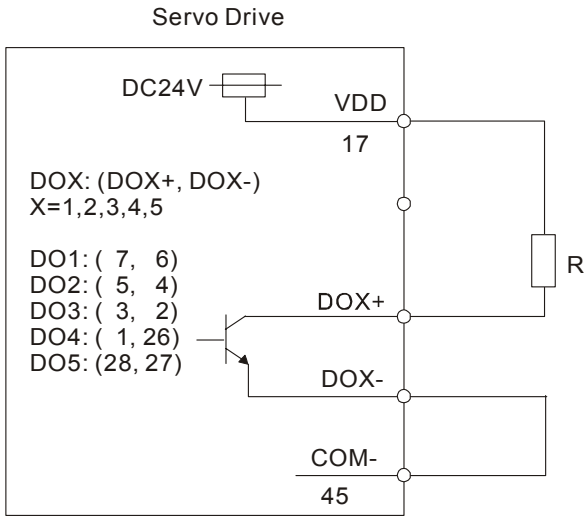

C6: Wiring of DO signal, for the use of internal power supply, inductive load

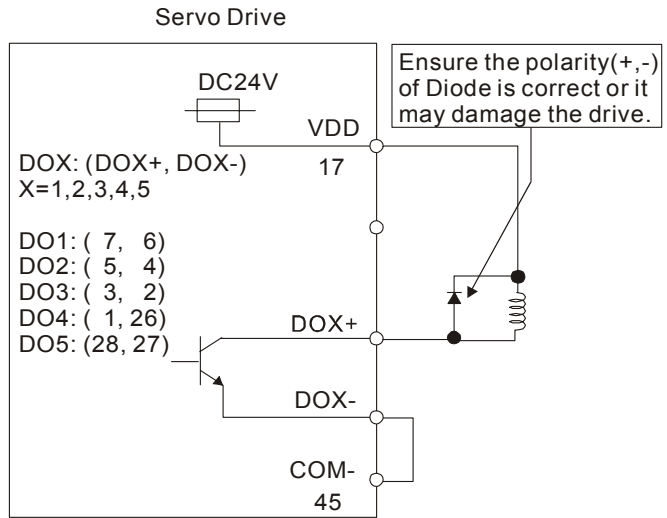

C7: Wiring of DO signal, for the use of external power supply, general load

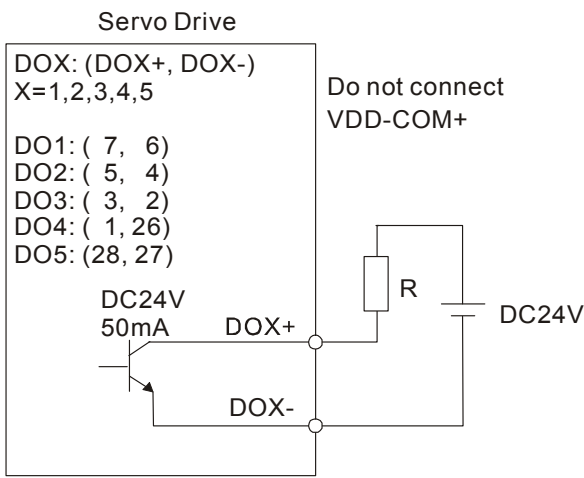

C8: Wiring of DO signal, for the use of external power supply, inductive load

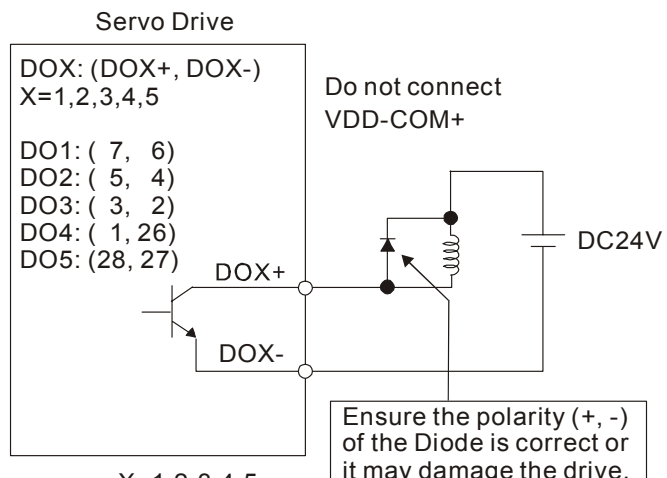

Chapter 3 Connections and Wiring | ASDA-A&A+ Series

Use a relay or open-collector transistor to input signal.

NPN transistor with multiple emitter fingers (SINK Mode)

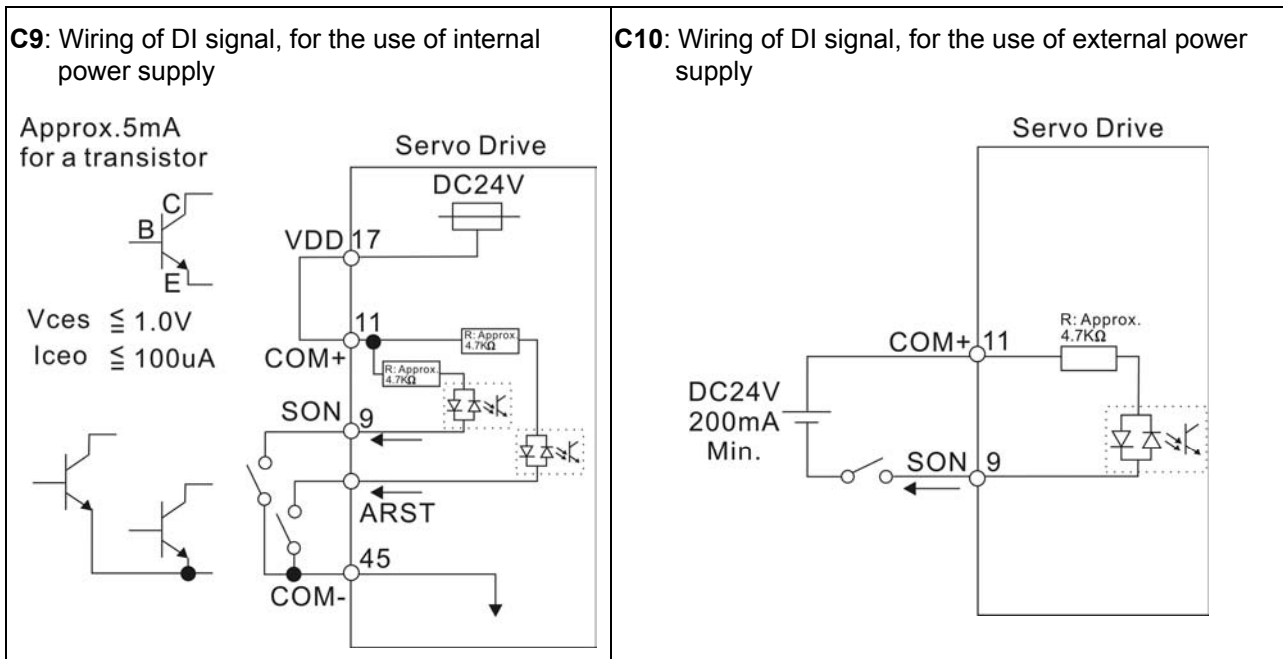

PNP transistor with multiple emitter fingers (SOURCE Mode)

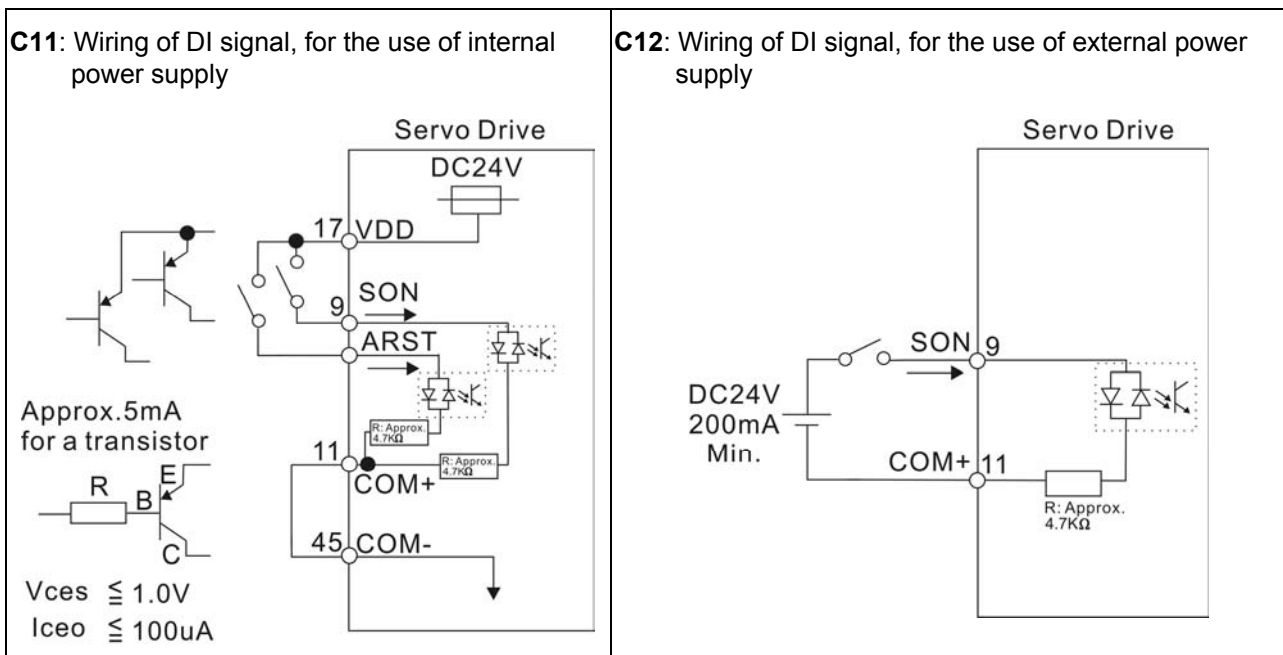

➤ **Caution:** Do not use dual power supply. Failure to observe this caution may result in damage to the servo drive and servo motor.

Chapter 3 Connections and Wiring | ASDA-A&A+ Series

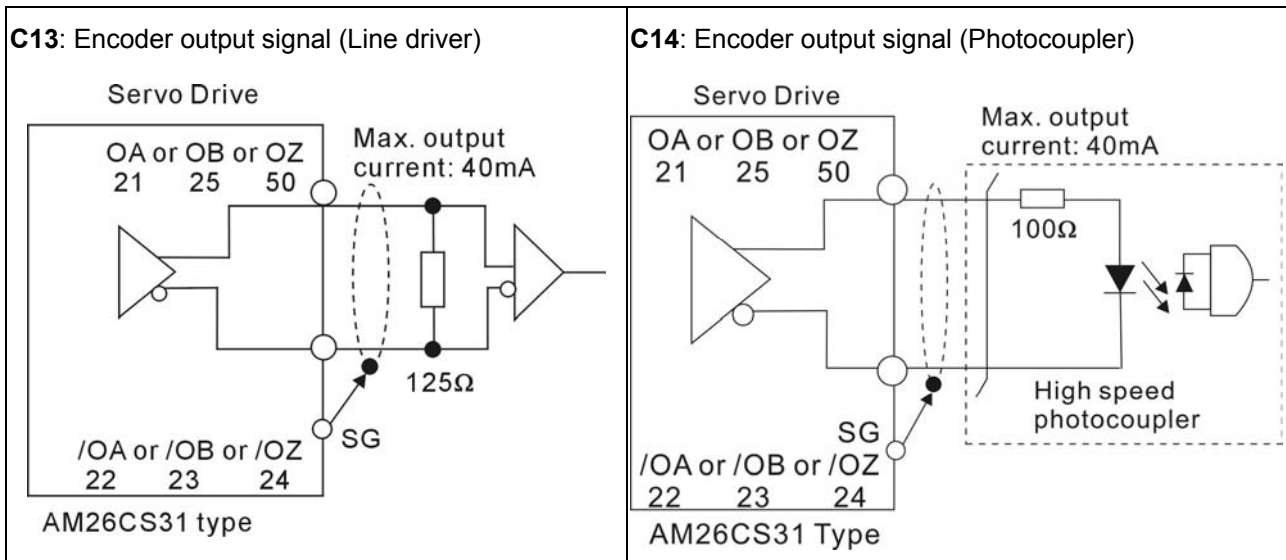

Chapter 3 Connections and Wiring | ASDA-A&A+ Series

3.4 Encoder Connector CN2

Integrated within the servo motor is an incremental encoder with 2,500PPR and commutation signal.

When power is first applied to the servo drive, control algorithms detect the motor's rotor position through imbedded sensors in the motor within 500msec approximately.

Feedback to the amplifier of the UVW signals for commutation is via the ABZ encoder signal wires.

Following rotor position sensing the amplifier automatically switches to encoding for commutation control.

The 2500PPR encoder is automatically multiplied to 10000PPR by X4 logic for increased control accuracy.

Figure 3.9 The layout of CN2 Drive Connector

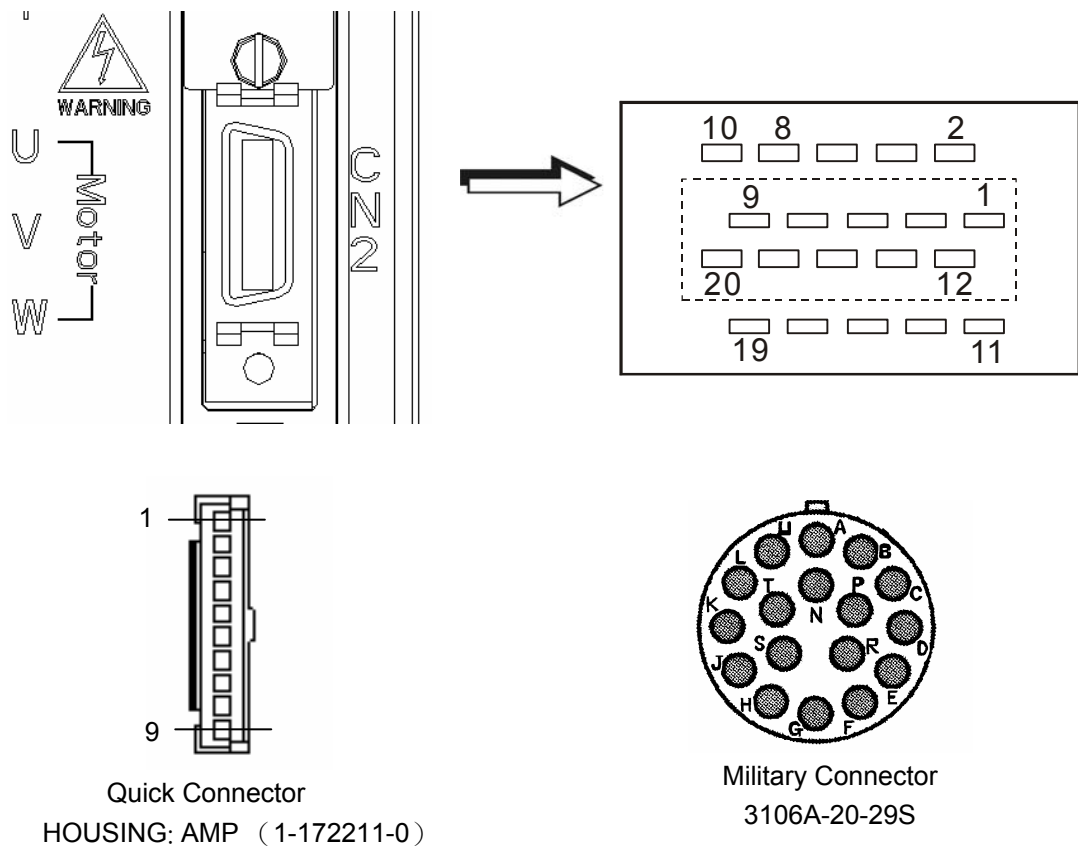

Chapter 3 Connections and Wiring | ASDA-A&A+ Series**CN2 Terminal Signal Identification****ASDA-A Series**

PIN No.	Signal Name	Terminal Identification	Military Connector	Quick Connector	Description
2	/Z phase input	/Z	G	6	Encoder /Z phase output
4	/A phase input	/A	B	2	Encoder /A phase output
5	A phase input	A	A	1	Encoder A phase output
7	B phase input	B	C	3	Encoder B phase output
9	/B phase input	/B	D	4	Encoder /B phase output
10	Z phase input	Z	F	5	Encoder Z phase output
14, 16	Encoder power	+5V	S	7	Encoder 5V power
13, 15	Encoder power	GND	R	8	Grounding
	Shielding	Shielding	L	9	Shielding

ASDA-A+ Series

PIN No.	Signal Name	Terminal Identification	Military Connector	Quick Connector	Description
4	Line driver /SD	/SD	B	2	Encoder line driver /SD signal output
5	Line driver SD	SD	A	1	Encoder line driver SD signal output
14,16	Encoder power	+5V	S	7	Encoder 5V power
13,15	Encoder power	GND	R	8	Grounding
	Shielding	Shielding	L	9	Shielding

3.5 Serial Communication Connector CN3

3.5.1 CN3 Terminal Layout and Identification

The servo drive can be connected to a PC or controller via a serial communication connector. Users can operate the servo drive through PC software supplied by Delta (contact to the dealer). The communication connector/port of Delta servo drive can provide three common serial communication interfaces: RS-232, RS-485, and RS-422 connection. RS-232 is mostly be used but is somewhat limited. The maximum cable length for an RS-232 connection is 15 meters (50 feet). Using RS-485 or RS-422 interface can allow longer distance for transmission and support multiple drives to be connected simultaneously.

Figure 3.10 The layout of CN3 Drive Connector

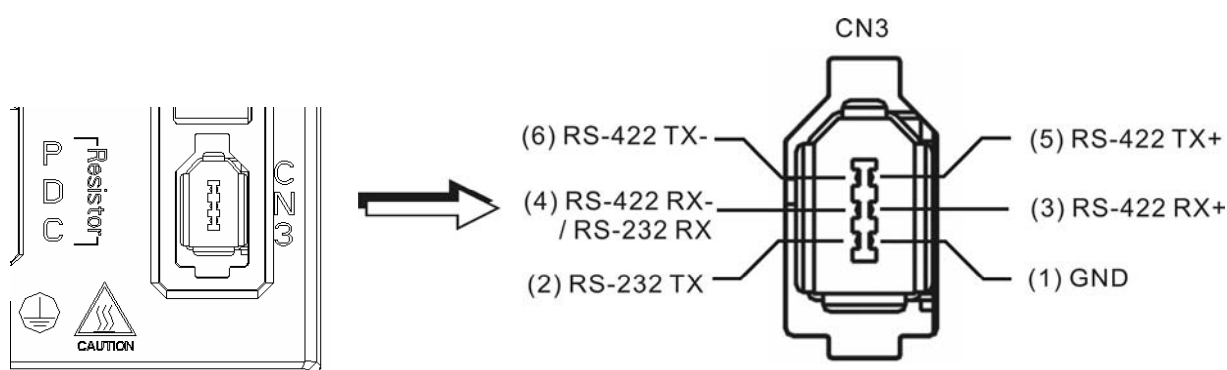

CN3 Terminal Signal Identification

PIN No.	Signal Name	Terminal Identification	Description
1	Grounding	GND	-
2	RS-232 data transmission	RS-232-TX	For data transmission of the servo drive. Connected to the RS-232 interface of PC.
3	RS-422 data receiving	RS-422-RX+	For data receiving of the servo drive (differential line driver + end)
4	RS-232 data receiving	RS-232_RX	For data receiving of the servo drive. Connected to the RS-232 interface of PC.
	RS-422 data receiving	RS-422_RX-	For data receiving of the servo drive (differential line driver - end)
5	RS-422 data transmission	RS-422-TX+	For data transmission of the servo drive (differential line driver + end)
6	RS-422 data transmission	RS-422-TX-	For data transmission of the servo drive (differential line driver - end)

NOTE

- 1) For the connection of RS-485, please refer to page 8.2 and 8.3.
- 2) There are two kinds of IEEE1394 communication cables available on the market. If the user uses one kind of cable, which its GND terminal (Pin 1) and its shielding is short-circuited, the communication may be damaged. Never connect the case of the terminal to the ground of this kind of communication cable.

Chapter 3 Connections and Wiring | ASDA-A&A+ Series

3.5.2 Connection between PC and Connector CN3

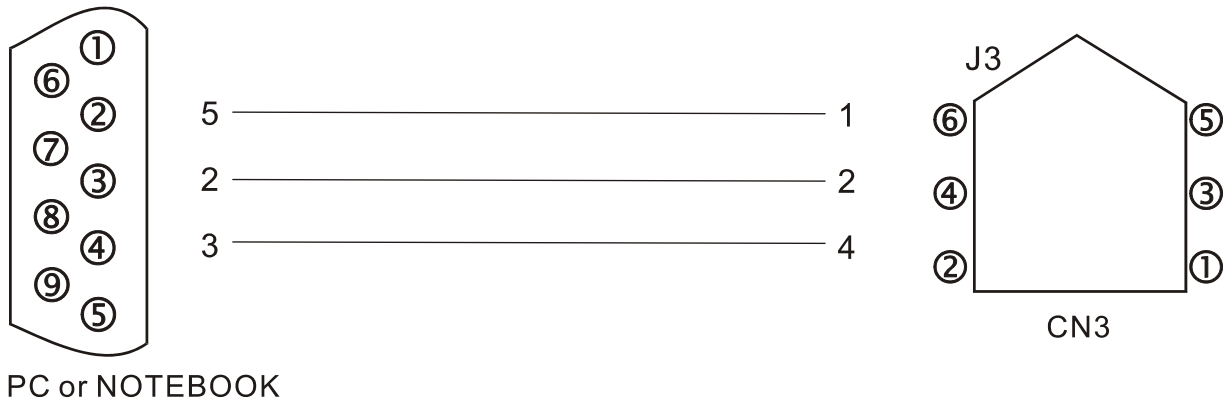

Chapter 3 Connections and Wiring | ASDA-A&A+ Series

3.6 Standard Connection Example

3.6.1 Position (Pt) Control Mode

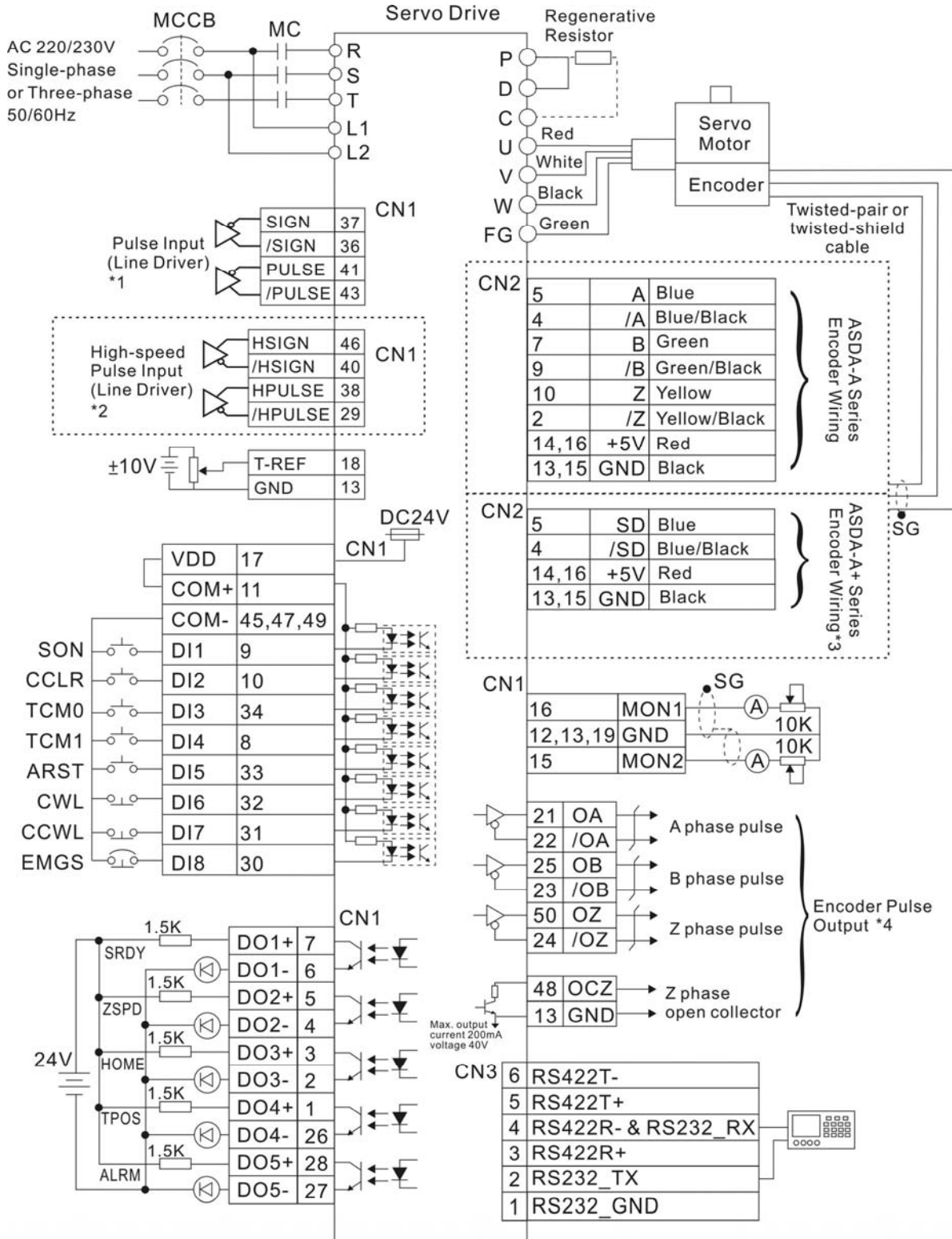

Note:

- 1 Please refer to C4 wiring diagram on page 3-28. If it is open-collector input, please refer to C3 wiring diagram on page 3-27.
- 2 These terminals are for ASDA-A+ series only. In ASDA-A series, they are marked NC (No Connection) and must be left unconnected.
- 3 CN2 encoder terminals for ASDA-A+ series only.
- 4 Please refer to parameter P1-46 in Chapter 7.

Chapter 3 Connections and Wiring | ASDA-A&A+ Series

3.6.2 Position (Pr) Control Mode

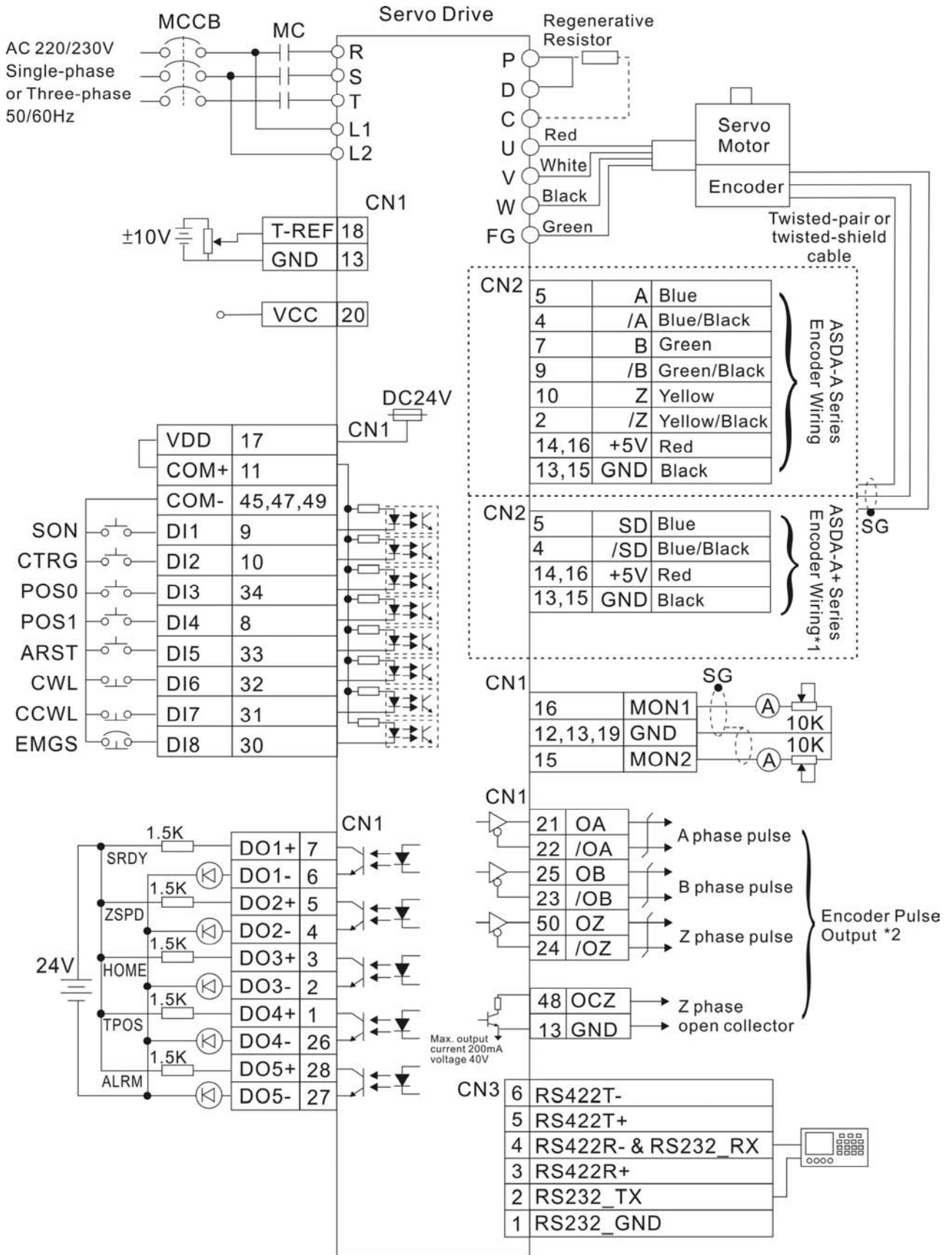

Note:

- 1 CN2 encoder terminals for ASDA-A+ series only.
- 2 Please refer to parameter P1-46 in Chapter 7.

Chapter 3 Connections and Wiring | ASDA-A&A+ Series

3.6.3 Speed Control Mode

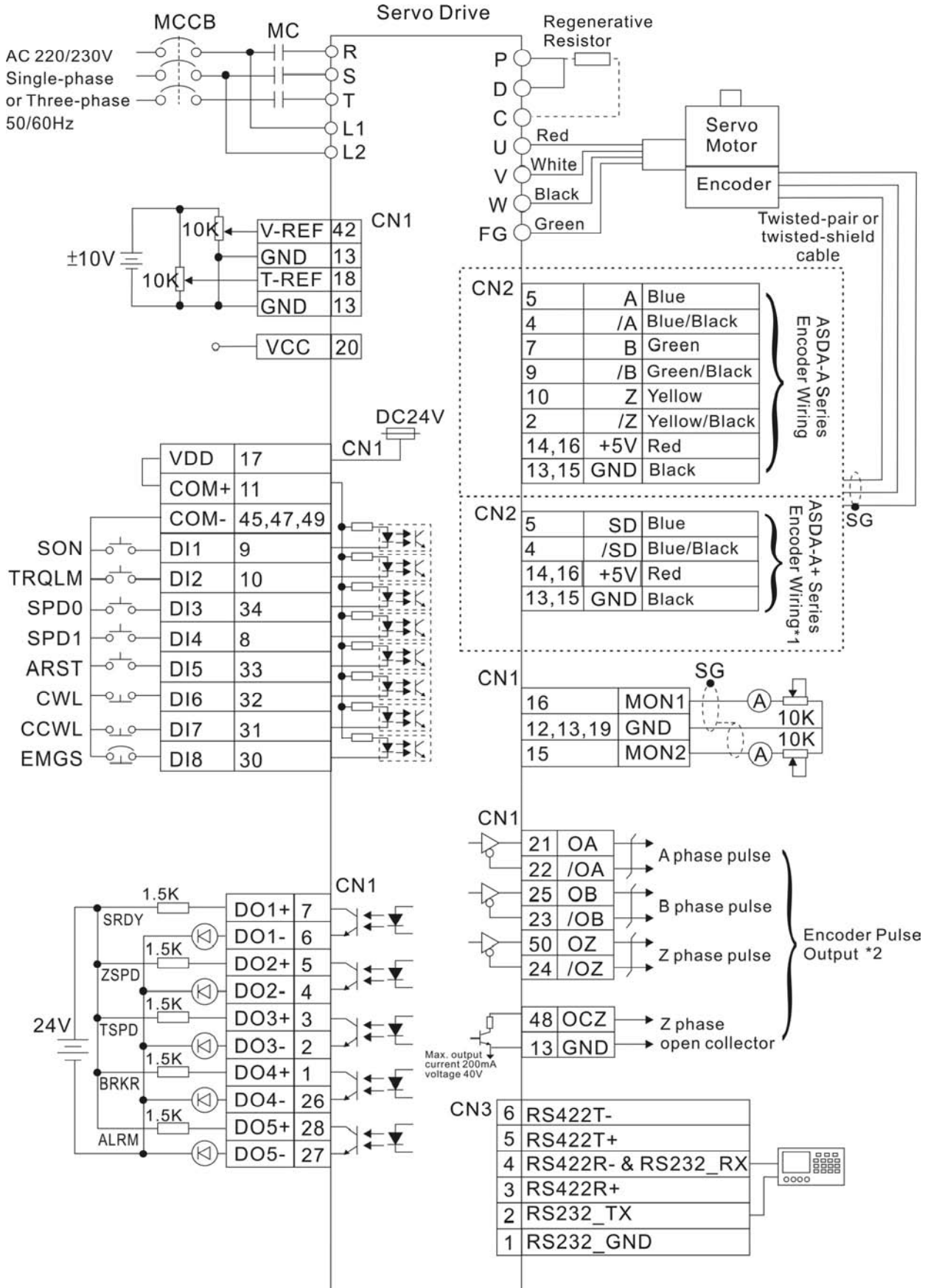

Note:

- 1 CN2 encoder terminals for ASDA-A+ series only.
- 2 Please refer to parameter P1-46 in Chapter 7.

Chapter 3 Connections and Wiring | ASDA-A&A+ Series

3.6.4 Torque Control Mode

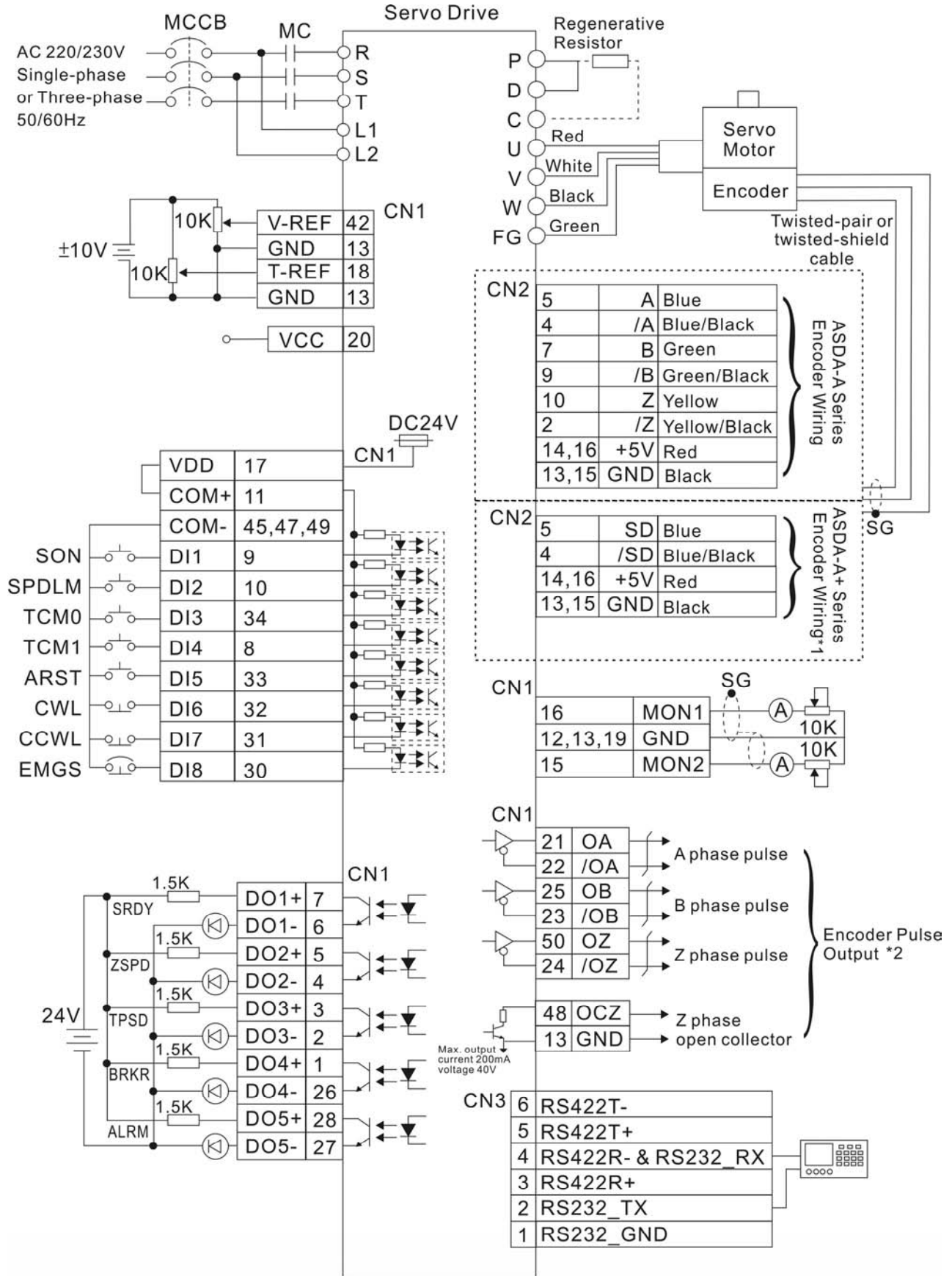

Chapter 4 Display and Operation

This chapter describes the basic operation of the digital keypad and the features it offers.

4.1 Description of the Digital Keypad

The digital keypad includes the display panel and function keys. The Figure 4.1 shows all of the features of the digital keypad and an overview of their functions.





Figure 4.1.1 100W ~ 5.5kW models



Figure 4.1.2 7.5kW model



Chapter 4 Display and Operation | ASDA-A&A+ Series

Name	Function
LCD Display	The LCD Display (5-digit, 7-step display panel) shows the monitor codes, parameter settings and operation values of the AC servo drive.
Charge LED	The Charge LED lights to indicate the power is applied to the circuit.
	MODE Key. Pressing MODE key can enter or exit different parameter groups, and switch between Monitor mode and Parameter mode.
	SHIFT Key. Pressing SHIFT key can scrolls through parameter groups. After a parameter is selected and its value displayed, pressing SHIFT key can move the cursor to the left and then change parameter settings (blinking digits) by using arrow keys.
	UP and DOWN arrow Key. Pressing the UP and DOWN arrow key can scroll through and change monitor codes, parameter groups and various parameter settings.
	SET Key. Pressing the SET key can display and save the parameter groups, the various parameter settings. During diagnosis operation, pressing SET key can execute the function in the last step. (The parameter settings changes are not effective until the SET key is pressed.)

Chapter 4 Display and Operation | ASDA-A&A+ Series

4.2 Display Flowchart

Figure 4.2 Keypad Operation

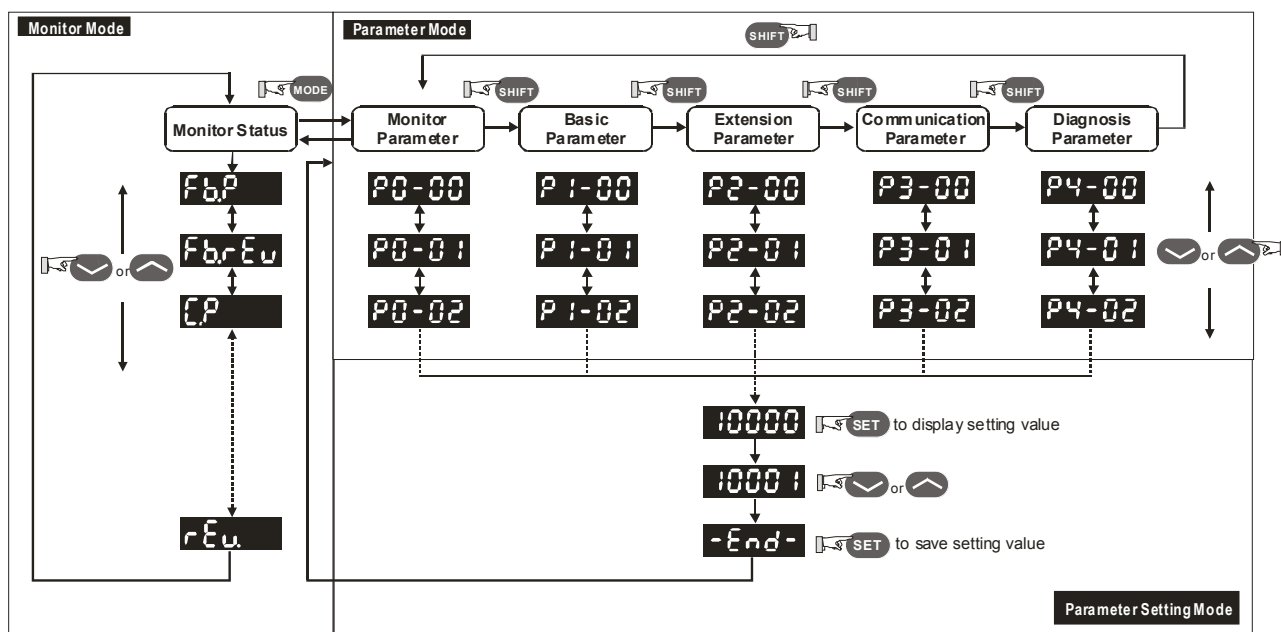







1. When the power is applied to the AC servo drive, the LCD display will show the monitor function codes for approximately one second, then enter into the monitor mode.
2. In monitor mode, pressing UP or DOWN arrow key can switch monitor parameter code. At this time, monitor display symbol will display for approximately one second.
3. In monitor mode, pressing MODE key can enter into parameter mode, pressing the SHIFT key can switch parameter group and pressing UP or DOWN arrow key can change parameter group code.
4. In parameter mode, the system will enter into the setting mode immediately after the Set key is pressed. The LCD display will display the corresponding setting value of this parameter simultaneously. Then, users can use UP or DOWN arrow key to change parameter value or press Mode to exit and return back to the parameter mode.
5. In parameter setting mode, the users can move the cursor to left by pressing the SHIFT key and change the parameter settings (blinking digits) by pressing the UP or DOWN arrow key.
6. After the setting value change is completed, press SET key to save parameter settings or execute command.
7. When the parameter setting is completed, LCD display will show the end code “-END-“ and automatically return back to parameter mode.

Chapter 4 Display and Operation | ASDA-A&A+ Series

4.3 Status Display

4.3.1 Save Setting Display

After the SET key is pressed, LCD display will show the following display messages for approx. one second according to different status.

Display Message	Description
	The setting value is saved correctly.
	This parameter is read only. Write-protected. (cannot be changed)
	Invalid password or no password was input.
	The setting value is error or invalid.
	The servo system is running and it is unable to accept this setting value to be changed.
	This parameter will not be stored in EEPROM.
	This parameter is valid after restarting the drive.



4.3.2 Abort Setting Display

Display Message	Description
	In parameter mode, pressing MODE key can abort parameter setting change and return to monitor mode. In parameter setting mode, pressing MODE key can return back to parameter mode. After returning back to parameter mode, pressing MODE key again can abort parameter setting change.

4.3.3 Fault Message Display

Display Message	Description
	When the AC servo drive has a fault, LCD display will display "ALenn". "ALE" indicates the alarm and "nn" indicates the drive fault code. The display range of alarm code "nn" is 1 to 22. For the list of drive fault code, please refer to parameter P0-01 or refer to Chapter 10 (Troubleshooting).

4.3.4 Polarity Setting Display

Display Message	Description
	Positive value display. When entering into parameter setting mode, pressing UP or DOWN arrow key can increase or decrease the display value. SHIFT key is used to change the selected digit (The selected digit will blink).
	Negative value display. When the parameter setting is greater than four digits (for the setting value within the range of less than five decimal places), after the display value is set, continuously press SHIFT key for many times and then the lit decimal points are used to indicate a negative value.















Chapter 4 Display and Operation | ASDA-A&A+ Series

Display Message	Description
	Negative value display. When the parameter setting is less than five digits (for the setting value within the range of five decimal places), after the display value is set, continuously press SHIFT key for many times and then the negative sign will show up to indicate a negative value.

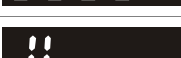

4.3.5 Monitor Setting Display

When the AC servo drive is applied to power, the LCD display will show the monitor function codes for approximately one second and then enter into the monitor mode. In monitor mode, in order to change the monitor status, the users can press UP or DOWN arrow key or change parameter P0-02 directly to specify the monitor status. When the power is applied, the monitor status depends on the setting value of P0-02. For example, if the setting value of P0-02 is 2 when the power is applied, the monitor function will be Pulse counts of pulse command, the C.P monitor codes will first display and then the pulse number will display after.



ASDA-A Series

P0-02 Setting	Display Message	Description	Unit
0		Motor feedback pulse number (Absolute value)	[pulse]
1		Motor feedback rotation number (Absolute value)	[rev]
2		Pulse counts of pulse command	[pulse]
3		Rotation number of pulse command	[rev]
4		Position error counts	[pulse]
5		Input frequency of pulse command	[r/min]
6		Motor rotation speed	[r/min]
7		Speed input command	[V]
8		Speed input command	[r/min]
9		Torque input command	[V]
10		Torque input command	[%]
11		Average load	[%]
12		Peak load	[%]
13		Main circuit voltage	[V]
14		Ratio of load inertia to Motor inertia	[times]





Chapter 4 Display and Operation | ASDA-A&A+ Series

P0-02 Setting	Display Message	Description	Unit
15		Motor feedback pulse number (Relative value) / Position latch pulse number	[pulse]
16		Motor feedback rotation number (Relative value) / Position latch rotation number	[rev]

ASDA-A+ Series

P0-02 Setting	Display Message	Description	Unit
17	-	Reserved	-
18		High resolution pulse number	[pulse]
19		Absolute pulse number (use Z pulse as home)	[pulse]

The following table lists the display examples of monitor value:

Display Message	Description
	Positive value display. No positive sign is displayed to indicate it is a positive value. Display value: +1234.
	Negative value display (The decimal place is greater than four). The lit decimal points are used to indicate it is a negative value. Display value: -12345.
	Negative value display (The decimal place is less than five). The negative sign is displayed to indicate it is a negative value. Display value: -1234.
	Decimal value display. Display value: 12.34.

4.4 General Function Operation

4.4.1 Fault Code Display Operation

After entering the parameter mode P4-00 to P4-04 (Fault Record), press SET key to display the corresponding fault code history for the parameter or press UP arrow key to display the fault code of H1 to H5 in order. H1 indicates the most recent occurred fault code, H2 is the previous occurred fault code before H1 and so on. Please refer to the Figure 4.3. The recently occurred error code is 10.

Figure 4.3

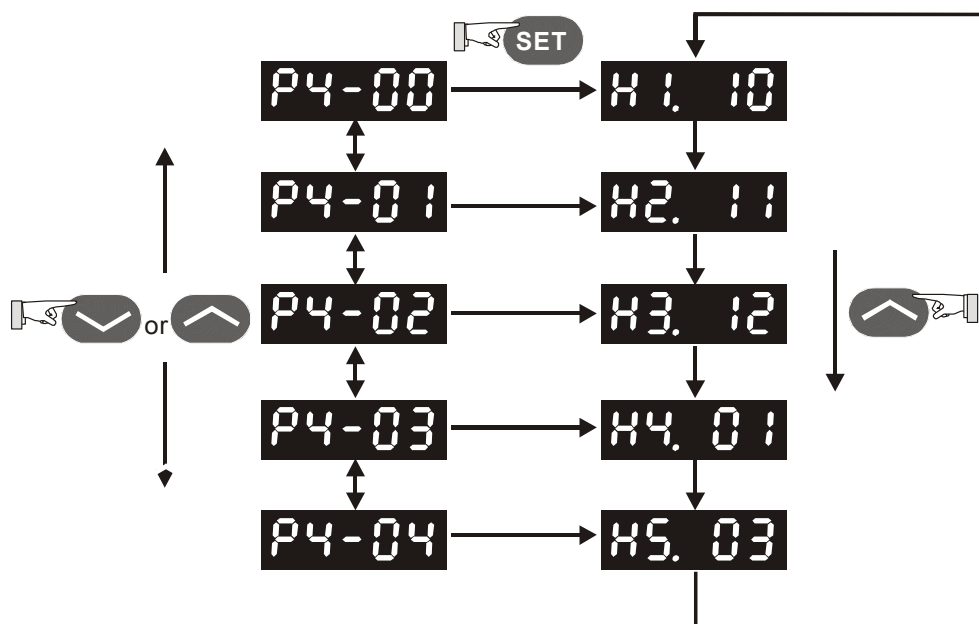

4.4.2 JOG Operation

After entering parameter mode P4-05, the users can follow the following steps to perform JOG operation. (Please also refer to Figure 4.4).

- Step1. Press the SET key to display the JOG r/min speed. (The default value is 20 r/min).
- Step2. Press the UP or DOWN arrow keys to increase or decrease the desired JOG speed. (This also can be undertaken by using the SHIFT key to move the cursor to the desired unit column (the effected number will blink) then changed using the UP and DOWN arrow keys. The example display in Figure 4.4 is adjusted as 100 r/min.)
- Step3. Press the SET key when the desired JOG speed is set. The Servo Drive will display "JOG".
- Step4. Press the UP or DOWN arrow keys to jog the motor either CCW or CW. The motor will only rotate while the arrow key is activated.
- Step5. To change JOG speed again, press the MODE key. The servo Drive will display "P4 - 05". Press the SET key and the JOG r/min speed will displayed again. Refer back to #2 and #3 to change speed.

NOTE

- 1) JOG operation is effective only when Servo On (when the servo drive is enabled).

Chapter 4 Display and Operation | ASDA-A&A+ Series

Figure 4.4

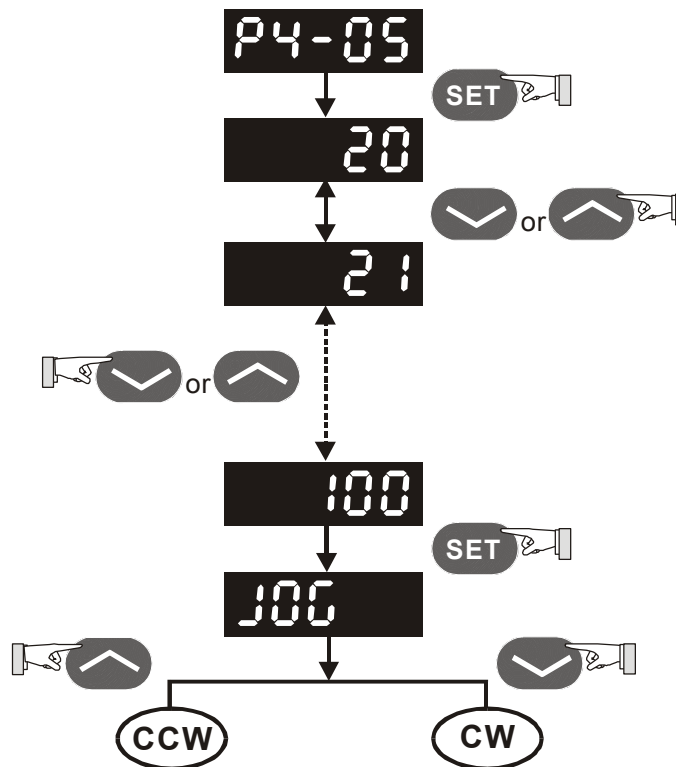

4.4.3 Position Learning Operation

Follow the following steps to perform position learning operation (Please also refer to Figure 4.5).

1. Activate the internal position learning function (Set P2-30=4).
2. After enter into parameter mode P4-05, press Set key and the LED display will show learning moving speed value. The default setting is 20 r/min.
3. Press UP or DOWN arrow key to set the desired moving speed value. In the example shown below, the value is adjusted to 100r/min.
4. Press Set key then JOG o1 will display and enter position learning mode.
5. In the position learning mode (display JOGox), pressing UP or DOWN arrow key at any time can rotate Servo motor in forward or reverse rotation. Servo motor will immediately stop running if releasing the UP or DOWN arrow key. This operation is only available during Servo system is On (Servo On).
6. After position is selected, press Set key then the display JOGo1 will change to JOGo2. At the same time, the absolute position of servo motor will be memorized inside of the memory. (P1-15 : 1st Position Command for Rotation, P1-16 : 1st Position Command for Pulse)
7. In the position learning mode (display JOGox), pressing Shift key can directly change the "x" value of the display "JOGox" so as to jump rapidly to the particular learning position where should be modified. There is no position memorized at this time.

Chapter 4 Display and Operation | ASDA-A&A+ Series

Figure 4.5

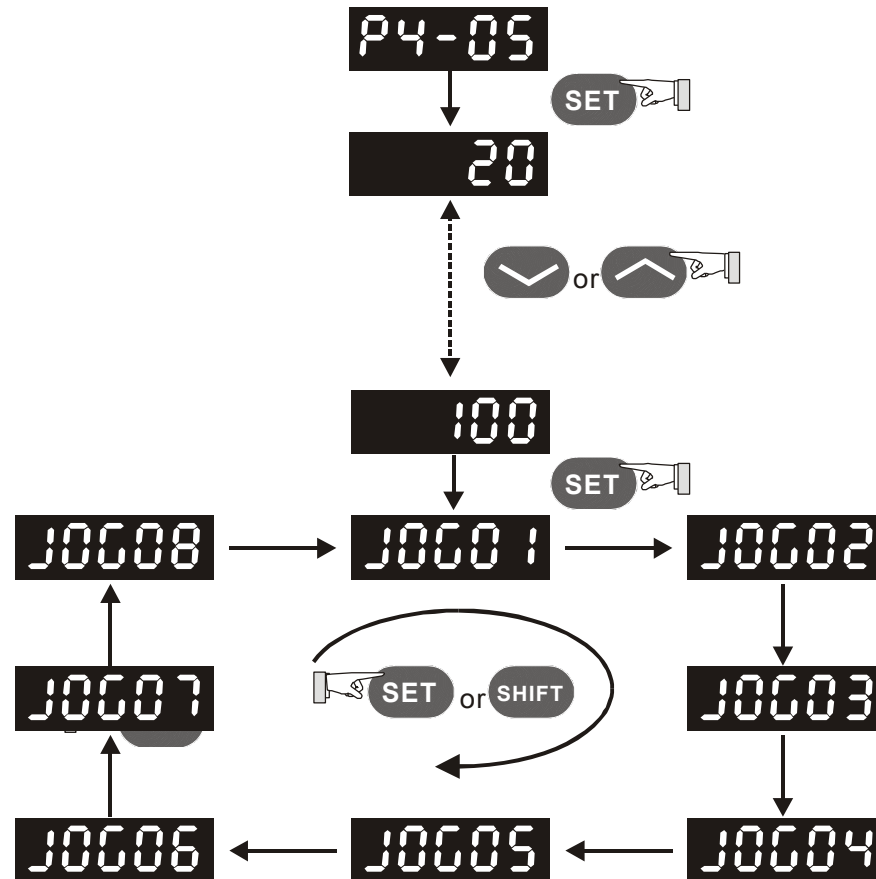

The learning position and internal memorized position are listed as below:

Learning Position	Internal Memorized Position
JOGo1	P1-15 (1st Position Command for Rotation) P1-16 (1st Position Command for Pulse)
JOGo2	P1-17 (2nd Position Command for Rotation) P1-18 (2nd Position Command for Pulse)
JOGo3	P1-19 (3rd Position Command for Rotation) P1-20 (3rd Position Command for Pulse)
JOGo4	P1-21 (4th Position Command for Rotation) P1-22 (4th Position Command for Pulse)
JOGo5	P1-23 (5th Position Command for Rotation) P1-24 (5th Position Command for Pulse)
JOGo6	P1-25 (6th Position Command for Rotation) P1-26 (6th Position Command for Pulse ber)
JOGo7	P1-27 (7th Position Command for Rotation) P1-28 (7th Position Command for Pulse)
JOGo8	P1-29 (8th Position Command for Rotation) P1-30 (8th Position Command for Pulse)

Chapter 4 Display and Operation | ASDA-A&A+ Series

4.4.4 Force Output Control Operation

For testing, the digital outputs can be forced to be activated (ON) or inactivated (OFF) by using parameter P4-06. Follow the setting method in Figure 4.6 to enter into Force Output Control operation (OP xx) mode ("xx" indicates the parameter range from 00 to 1F). Pressing UP or DOWN arrow key can change "xx" value from 00 to 1F (hexadecimal format) and force digital outputs DO1 to DO5 to be activated (ON) or inactivated (OFF). The DO function and status is determined by P2-18 to P2-22. This function is enabled only when Servo Off (the servo drive is disabled).

Figure 4.6

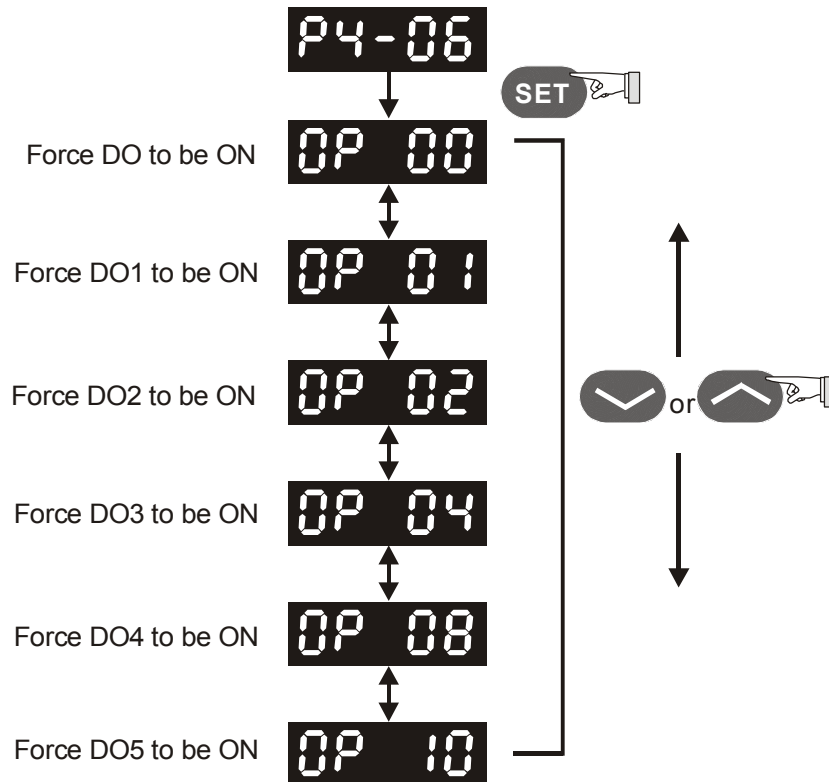

Chapter 4 Display and Operation | ASDA-A&A+ Series

4.4.5 DI Diagnosis Operation

Following the setting method in Figure 4.7 can perform DI diagnosis operation (parameter P4-07, Input Status or Force Input Control). According to the ON and OFF status of the digital inputs DI1 to DI8, the corresponding status will display on the servo drive LED display. When the segment lit and display on the screen, it means that the corresponding digital input signal is ON. (Please also refer to Figure 4.7)

Figure 4.7

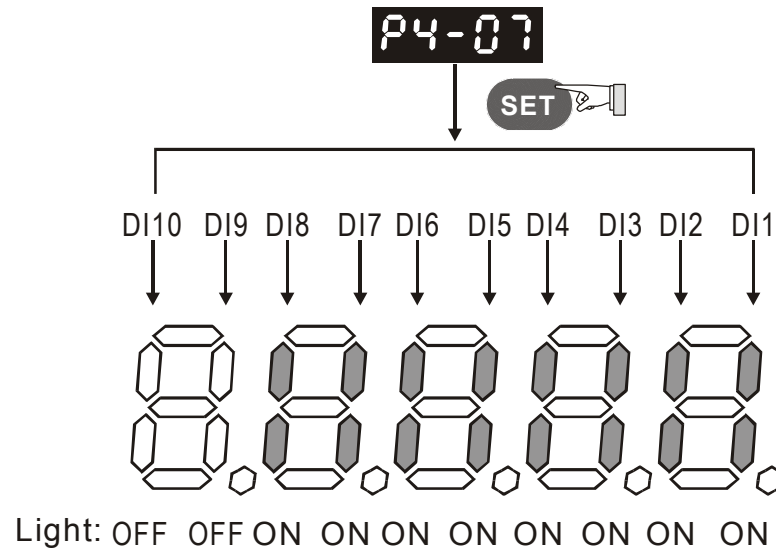

4.4.6 DO Diagnosis Operation

Following the setting method in Figure 4.8 can perform DO diagnosis operation (parameter P4-09, Output Status Display). According to the ON and OFF status of the digital outputs DO1 to DO5, the corresponding status will display on the servo drive LED display. When the segment lit and display on the screen, it means that the corresponding digital input signal is ON. (Please also refer to Figure 4.8)

Figure 4.8

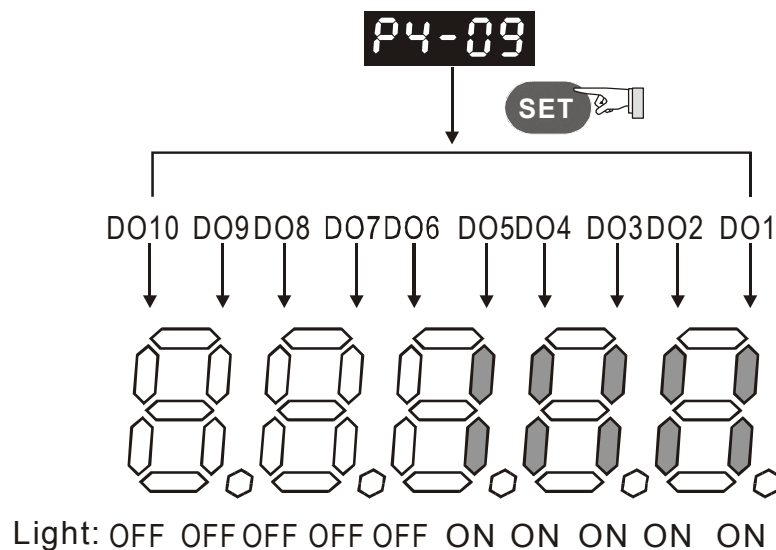

Chapter 4 *Display and Operation* | ASDA-A&A+ Series

This page intentionally left blank.

Chapter 5 Trial Run and Tuning Procedure

This chapter, which is divided into two parts, describes trial run for servo drive and motor. One part is to introduce the trial run without load, and the other part is to introduce trial run with load. Ensure to complete the trial run without load first before performing the trial run with load.

5.1 Inspection without Load

In order to prevent accidents and avoid damaging the servo drive and mechanical system, the trial run should be performed under no load condition (no load connected, including disconnecting all couplings and belts). Do not run servo motor while it is connected to load or mechanical system because the unassembled parts on motor shaft may easily disassemble during running and it may damage mechanical system or even result in personnel injury. After removing the load or mechanical system from the servo motor, if the servo motor can run normally following up the normal operation procedure (when trial run without load is completed), then the users can connect to the load and mechanical system to run the servo motor.



- *In order to prevent accidents, the initial trial run for servo motor should be conducted under no load conditions (separate the motor from its couplings and belts).*
- *Caution: Please perform trial run without load first and then perform trial run with load connected. After the servo motor is running normally and regularly without load, then run servo motor with load connected. Ensure to perform trial run in this order to prevent unnecessary danger.*

After power is connected to AC servo drive, the charge LED will light and it indicates that AC servo drive is ready. Please check the followings before trial run:

Item	Content
Inspection before operation (Control power is not applied)	<ul style="list-style-type: none"> ● Inspect the servo drive and servo motor to insure they were not damaged. ● To avoid an electric shock, be sure to connect the ground terminal of servo drive to the ground terminal of control panel. ● Before making any connection, wait 10 minutes for capacitors to discharge after the power is disconnected, alternatively, use an appropriate discharge device to discharge. ● Ensure that all wiring terminals are correctly insulated. ● Ensure that all wiring is correct or damage and or malfunction may result. ● Visually check to ensure that there are not any unused screws, metal strips, or any conductive or inflammable materials inside the drive. ● Never put inflammable objects on servo drive or close to the external regenerative resistor. ● Make sure control switch is OFF. ● If the electromagnetic brake is being used, ensure that it is correctly wired. ● If required, use an appropriate electrical filter to eliminate noise to the servo drive. ● Ensure that the external applied voltage to the drive is correct and matched to the controller.

Chapter 5 Trial Run and Tuning Procedure | ASDA-A&A+ Series

Item	Content
Inspection during operation (Control power is applied)	<ul style="list-style-type: none"> ● Ensure that the cables are not damaged, stressed excessively or loaded heavily. When the motor is running, pay close attention on the connection of the cables and notice that if they are damaged, frayed or over extended. ● Check for abnormal vibrations and sounds during operation. If the servo motor is vibrating or there are unusual noises while the motor is running, please contact the dealer or manufacturer for assistance. ● Ensure that all user-defined parameters are set correctly. Since the characteristics of various machinery equipment are different, in order to avoid accident or cause damage, do not adjust the parameter abnormally and ensure the parameter setting is not an excessive value. ● Ensure to reset some parameters when the servo drive is off (Please refer to Chapter 7). Otherwise, it may result in malfunction. ● If there is no contact sound or there be any unusual noises when the relay of the servo drive is operating, please contact your distributor for assistance or contact with Delta. ● Check for abnormal conditions of the power indicators and LED display. If there is any abnormal condition of the power indicators and LED display, please contact your distributor for assistance or contact with Delta.

Chapter 5 Trial Run and Tuning Procedure | ASDA-A&A+ Series

5.2 Applying Power to the Drive

The users please observe the following steps when applying power supply to the servo drive.

1. Please check and confirm the wiring connection between the drive and motor is correct.
 - 1) Terminal U, V, W and FG (frame ground) must connect to Red, White, Black and Green cables separately (U: Red, V: White, W: Black, FG: Green). If not connect to the specified cable and terminal, then the drive cannot control motor. The motor grounding lead, FG must connect to grounding terminal. For more information of cables, please refer to section 3.1.
 - 2) Ensure to connect encoder cable to CN2 connector correctly. If the users only desire to execute JOG operation, it is not necessary to make any connection to CN1 and CN3 connector. For more information of the connection of CN2 connector, please refer to Section 3.1 and 3.4.



➤ *Do not connect the AC input power (R, S, T) to the (U, V, W) output terminals. This will damage the AC servo drive.*

2. Main circuit wiring

Connect power to the AC servo. For three-phase input power connection and single-phase input power connection, please refer to Section 3.1.3.

3. Turn the Power On

The Power includes control circuit power (L1, L2) and main circuit power (R, S, T). When the power is on, the normal display should be shown as the following figure:

As the default settings of digital input signal, DI6, DI7 and DI8 are Reverse Inhibit Limit (CWL), Forward Inhibit Limit (CCWL) and Emergency Stop (EMGS) respectively, if the users do not want to use the default settings of DI6~DI8, the users can change their settings by using parameters P2-15 to P2-17 freely. When the setting value of parameters P2-15 to P2-17 is 0, it indicates the function of this DI signal is disabled. For more information of parameters P2-15 to P2-17, please refer to Chapter 7 "Parameters".

If the parameter P0-02 is set as motor speed (06), the normal display should be shown as the following figure:

If there is no text or character displayed on the LED display, please check if the voltage of the control circuit terminal (L1 and L2) is over low.

Chapter 5 Trial Run and Tuning Procedure | ASDA-A&A+ Series

1) When display shows:

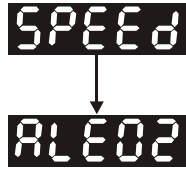

Over voltage:

The main circuit voltage has exceeded its maximum allowable value or input power is error (Incorrect power input).

Corrective Actions:

- Use voltmeter to check whether the input voltage falls within the rated input voltage.
- Use voltmeter to check whether the input voltage is within the specified limit.

2) When display shows:

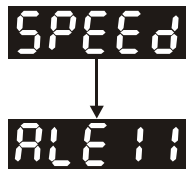

Encoder error:

Check if the wiring is correct. Check if the encoder wiring (CN2) of servo motor is loose or incorrect.

Corrective Actions:

- Check if the users perform wiring recommended in the user manual.
- Examine the encoder connector and cable.
- Inspect whether wire is loose or not.
- Check if the encoder is damaged.

3) When display shows:

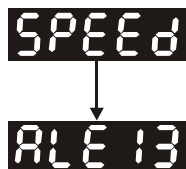

Emergency stop activated:

Please check if any of digital inputs DI1~DI8 signal is set to "Emergency Stop" (EMGS).

Corrective Actions:

- If it does not need to use "Emergency Stop (EMGS)" as input signal, the users only need to confirm that if all of the digital inputs DI1~DI8 are not set to "Emergency Stop (EMGS)". (The setting value of parameter P2-10 to P2-17 is not set to 21.)

Chapter 5 Trial Run and Tuning Procedure | ASDA-A&A+ Series

- If it is necessary to use “Emergency Stop (EMGS)” as input signal, the users only need to confirm that which of digital inputs DI1~DI8 is set to “Emergency Stop (EMGS)” and check if the digital input signal is ON (It should be activated).

4) When display shows:

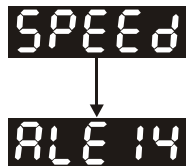

Reverse limit switch error:

Please check if any of digital inputs DI1~DI8 signal is set to “Reverse inhibit limit (CWL)” and check if the signal is ON or not.

Corrective Actions:

- If it does not need to use “Reverse inhibit limit (CWL)” as input signal, the users only need to confirm that if all of the digital inputs DI1~DI8 are not set to “Reverse inhibit limit (CWL)”. (The setting value of parameter P2-10 to P2-17 is not set to 22.)
- If it is necessary to use “Reverse inhibit limit (CWL)” as input signal, the users only need to confirm that which of digital inputs DI1~DI8 is set to “Reverse inhibit limit (CWL)” and check if the digital input signal is ON (It should be activated).

5) When display shows:

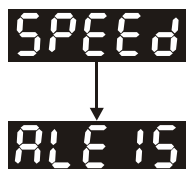

Forward limit switch error:

Please check if any of digital inputs DI1~DI8 signal is set to “Forward inhibit limit (CCWL)” and check if the signal is ON or not.

Corrective Actions:

- If it is no need to use “Forward inhibit limit (CCWL)” as input signal, the users only need to confirm that if all of the digital inputs DI1~DI8 are not set to “Forward inhibit limit (CCWL)”. (The setting value of parameter P2-10 to P2-17 is not set to 23.)
- If it is necessary to use “Forward inhibit limit (CCWL)” as input signal, the users only need to confirm that which of digital inputs DI1~DI8 is set to “Forward inhibit limit (CCWL)” and check if the digital input signal is ON (It should be activated).

Chapter 5 Trial Run and Tuning Procedure | ASDA-A&A+ Series

When “Digital Input 1 (DI1)” is set to Servo On (SON), if DI1 is set to ON (it indicates that Servo On (SON) function is enabled) and the following fault message shows on the display:

6) When display shows:

The image shows a digital LED display with the text "ALE01" in a white, segmented font on a black background.

Overcurrent:

Corrective Actions:

- Check the wiring connections between the servo drive and motor.
- Check if the circuit of the wiring is closed.
- Remove the short-circuited condition and avoid metal conductor being exposed.

7) When display shows:

The image shows a digital LED display with the text "ALE03" in a white, segmented font on a black background.

Undervoltage:

Corrective Actions:

- Check whether the wiring of main circuit input voltage is normal.
- Use voltmeter to check whether input voltage of main circuit is normal.
- Use voltmeter to check whether the input voltage is within the specified specification.

NOTE

-
- 1) If there are any unknown fault codes and abnormal display when applying power to the drive or servo on is activated (without giving any command), please inform the distributor or contact with Delta for assistance.

Chapter 5 Trial Run and Tuning Procedure | ASDA-A&A+ Series

5.3 JOG Trial Run without Load

It is very convenient to use JOG trial run without load to test the servo drive and motor as it can save the wiring. The external wiring is not necessary and the users only need to connect the digital keypad to the servo drive. For safety, it is recommended to set JOG speed at low speed. Please refer to the following steps to perform JOG trial run without load.

STEP 1: Turn the drive ON through software. Ensure that the setting value of parameter P2-30 should be set to 1 (Servo On).

STEP 2: Set parameter P4-05 as JOG speed (unit: r/min). After the desired JOG speed is set, and then press SET key, the drive will enter into JOG operation mode automatically

STEP 3: The users can press UP and DOWN key to change JOG speed and press SHIFT key to adjust the digit number of the displayed value.

STEP 4: Pressing SET key can determine the speed of JOG operation.

STEP 5: Pressing UP key and the servo motor will run in CCW direction. After releasing UP key, the motor will stop running.

STEP 6: Pressing DOWN key and the servo motor will run in CW direction. After releasing DOWN key, the motor will stop running.

CW and CCW Definition:

CCW (Counterclockwise): when facing the servo motor shaft, CCW is reverse running.

CW (Clockwise): when facing the servo motor shaft, CW is forward running.

STEP 7: When pressing MODE key, it can exit JOG operation mode.

In the example below, the JOG speed is adjusted from 20r/min (Default setting) to 100r/min.

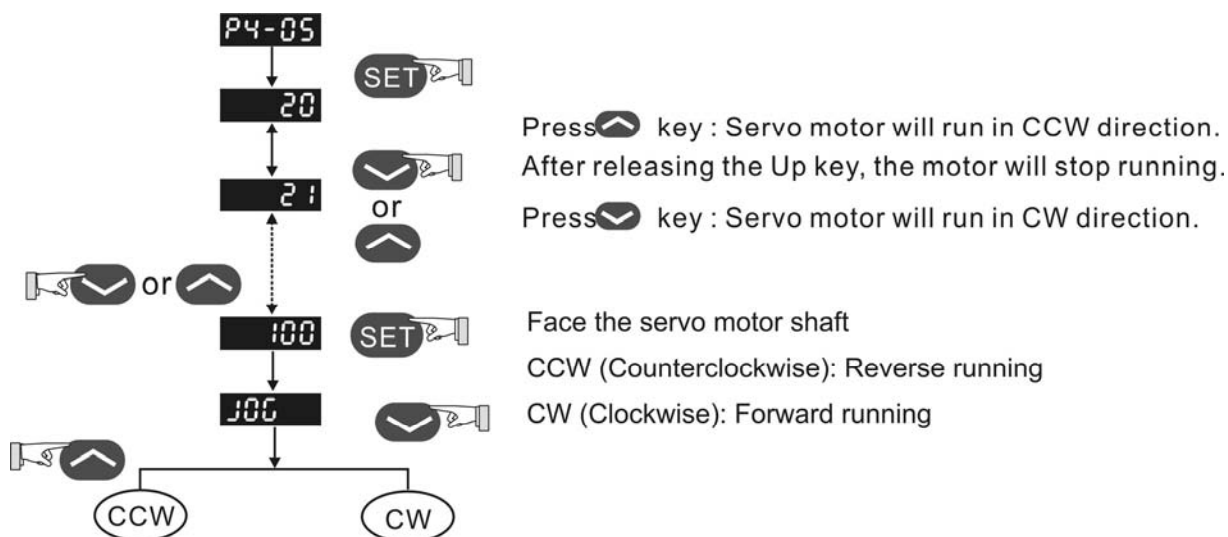

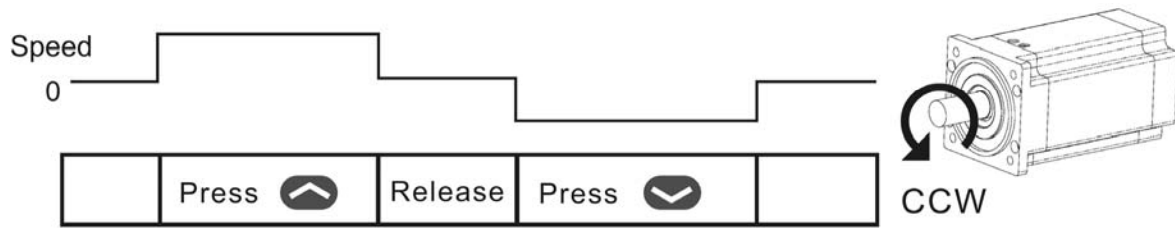
Chapter 5 Trial Run and Tuning Procedure | ASDA-A&A+ Series

If the servo motor does not rotate, please check if the wiring of U, V, W terminals and encoder is correct or not.

If the servo motor does not rotate properly, please check if the phase of U, V, W cables is connected correctly.

Chapter 5 Trial Run and Tuning Procedure | ASDA-A&A+ Series

5.4 Speed Trial Run without Load

Before speed trial run, fix and secure the motor as possible to avoid the danger from the reacting force when motor speed changes.

STEP 1:

Set the value of parameter P1-01 to 02 and it is speed (S) control mode. After selecting the operation mode as speed (S) control mode, please restart the drive as P1-01 is effective only after the servo drive is restarted (after switching power off and on).

STEP 2:

In speed control mode, the necessary Digital Inputs are listed as follows:

Digital Input	Parameter Setting Value	Sign	Function Description	CN1 PIN No.
DI1	P2-10=101	SON	Servo On	DI1-=9
DI2	P2-11=109	TRQLM	Torque limit enabled	DI2-=10
DI3	P2-12=114	SPD0	Speed command selection	DI3-=34
DI4	P2-13=115	SPD1	Speed command selection	DI4-=8
DI5	P2-14=102	ARST	Reset	DI5-=33
DI6	P2-15=0	Disabled	This DI function is disabled	-
DI7	P2-16=0	Disabled	This DI function is disabled	-
DI8	P2-17=0	Disabled	This DI function is disabled	-

By default, DI6 is the function of reverse inhibit limit, DI7 is the function of forward inhibit limit and DI8 is the function of emergency stop (DI8), if the users do not set the setting value of parameters P2-15 to P2-17 to 0 (Disabled), the faults (ALE13, 14 and 15) will occur (For the information of fault messages, please refer to Chapter 10). Therefore, if the users do not need to use these three digit inputs, please set the setting value of parameters P2-15 to P2-17 to 0 (Disabled) in advance.

All the digital inputs of Delta ASDA-A series are user-defined, and the users can set the DI signals freely. Ensure to refer to the definitions of DI signals before defining them (For the description of DI signals, please refer to Table 7.A in Chapter 7). If any alarm code displays after the setting is completed, the users can restart the drive or set DI5 to be activated to clear the fault. Please refer to section 5.2.

The speed command is selected by SPD0, SPD1. Please refer to the following table:

Speed Command No.	DI signal of CN1		Command Source	Content	Range
	SPD1	SPD0			
S1	0	0	External analog command	Voltage between V-REF and GND	+/- 10V
S2	0	1	Internal parameter	P1-09	+/- 5000r/min
S3	1	0		P1-10	+/- 5000r/min
S4	1	1		P1-11	+/- 5000r/min

0: indicates OFF (Normally Open); 1: indicates ON (Normally Closed)

Chapter 5 Trial Run and Tuning Procedure | ASDA-A&A+ Series

The settings of speed command:

P1-09 is set to 3000

P1-10 is set to 100

P1-11 is set to -3000

Input value command	Rotation direction
+	CCW
-	CW

STEP 3:

1. The users can use DI1 to enable the servo drive (Servo ON).
2. If DI3 (SPD0) and DI4 (SPD1) are OFF both, it indicates S1 command is selected. At this time, the motor is operating according to external analog command.
3. If only DI3 is ON (SPD0), it indicates S2 command (P1-09 is set to 3000) is selected, and the motor speed is 3000r/min at this time.
4. If only DI4 is ON (SPD1), it indicates S3 command (P1-10 is set to 100) is selected, and the motor speed is 100r/min at this time.
5. If DI3 (SPD0) and DI4 (SPD1) are ON both, it indicates S4 command (P1-11 is set to -3000) is selected, and the motor speed is -3000r/min at this time.
6. Repeat the action of (3), (4), (5) freely.
7. When the users want to stop the speed trial run, use DI1 to disable the servo drive (Servo OFF).

Chapter 5 Trial Run and Tuning Procedure | ASDA-A&A+ Series

5.5 Position Trial Run without Load

Before position trial run, fix and secure the motor as possible to avoid the danger from the reacting force when the motor speed changes.

STEP 1:

Set the value of parameter P1-01 to 01 and it is position (Pr) control mode. After selecting the operation mode as position (Pr) control mode, please restart the drive and the setting would be valid.

STEP 2:

In position control mode, the necessary DI setting is listed as follows:

Digital Input	Parameter Setting Value	Sign	Function Description	CN1 PIN No.
DI1	P2-10=101	SON	Servo On	DI1-=9
DI2	P2-11=108	CTRG	Command triggered	DI2-=10
DI3	P2-12=111	POS0	Position command selection	DI3-=34
DI4	P2-13=112	POS1	Position command selection	DI4-=8
DI5	P2-14=102	ARST	Reset	DI5-=33
DI6	P2-15=0	Disabled	This DI function is disabled	-
DI7	P2-16=0	Disabled	This DI function is disabled	-
DI8	P2-17=0	Disabled	This DI function is disabled	-

By default, DI6 is the function of reverse inhibit limit, DI7 is the function of forward inhibit limit and DI8 is the function of emergency stop (DI8), if the users do not set the setting value of parameters P2-15 to P2-17 to 0 (Disabled), the faults (ALE13, 14 and 15) will occur (For the information of fault messages, please refer to Chapter 10). Therefore, if the users do not need to use these three digit inputs, please set the setting value of parameters P2-15 to P2-17 to 0 (Disabled) in advance.

All the digital inputs of Delta ASDA-A series are user-defined, and the users can set the DI signals freely. Ensure to refer to the definitions of DI signals before defining them (For the description of DI signals, please refer to Table 7.A in Chapter 7). If any alarm code displays after the setting is completed, the users can restart the drive or set DI5 to be activated to clear the fault. Please refer to section 5.2.

For the information of wiring diagram, please refer to Section 3.6.2 (Wiring of position (Pr) control mode). Because POS2 is not the default DI, the users need to change the value of parameter P2-14 to 113.

Chapter 5 Trial Run and Tuning Procedure | ASDA-A&A+ Series

The position command is selected by POS0 ~ POS2. Please refer to the following table:

Position Command	POS2	POS1	POS0	CTRG	Parameters	Moving Speed Register	Description
Internal Position 1	0	0	0	↑	P1-15	P2-36 (V1)	Rotation No. (+/- 30000)
					P1-16		Pulse No. (+/- max cnt)
Internal Position 2	0	0	1	↑	P1-17	P2-37 (V2)	Rotation No. (+/- 30000)
					P1-18		Pulse No. (+/- max cnt)
Internal Position 3	0	1	0	↑	P1-19	P2-38 (V3)	Rotation No. (+/- 30000)
					P1-20		Pulse No. (+/- max cnt)
Internal Position 4	0	1	1	↑	P1-21	P2-39 (V4)	Rotation No. (+/- 30000)
					P1-22		Pulse No. (+/- max cnt)
Internal Position 5	1	0	0	↑	P1-23	P2-40 (V5)	Rotation No. (+/- 30000)
					P1-24		Pulse No. (+/- max cnt)
Internal Position 6	1	0	1	↑	P1-25	P2-41 (V6)	Rotation No. (+/- 30000)
					P1-26		Pulse No. (+/- max cnt)
Internal Position 7	1	1	0	↑	P1-27	P2-42 (V7)	Rotation No. (+/- 30000)
					P1-28		Pulse No. (+/- max cnt)
Internal Position 8	1	1	1	↑	P1-29	P2-43 (V8)	Rotation No. (+/- 30000)
					P1-30		Pulse No. (+/- max cnt)

0: indicates OFF (Normally Open); 1: indicates ON (Normally Closed)

The users can set the value of these 8 groups of commands (P1-15 ~ P1-30) freely. The command can be absolute position command (P1-33 = 0) or relative position command (P1-33 = 1).

For example:

Set P1-33 to 1 (Absolute position command)

(The new setting will be effective after the servo drive is restarted (after switching power off and on))

Set P1-15 to 1 (rotation number)

Set P1-16 to 0 (pulse number)

The command of internal position 1: P1-15 Rotation No. + P1-16 Pulse No.

Set P1-17 to 10 (rotation number)

Set P1-18 to 0 (pulse number)

The command of internal position 2: P1-17 Rotation No. + P1-18 Pulse No.

Set P1-19 to -10 (rotation number)

Set P1-20 to 0 (pulse number)

The command of internal position 3: P1-19 Rotation No. + P1-20 Pulse No.

Set P1-21 to 100 (rotation number)

Set P1-22 to 0 (pulse number)

The command of internal position 4: P1-21 Rotation No. + P1-22 Pulse No.

Set P1-23 to -1000 (rotation number)

Set P1-24 to 0 (pulse number)

The command of internal position 5: P1-23 Rotation No. + P1-24 Pulse No.

Chapter 5 Trial Run and Tuning Procedure | ASDA-A&A+ Series

Set P1-25 to 0 (rotation number)

Set P1-26 to 100 (pulse number)

The command of internal position 6: P1-25 Rotation No. + P1-26 Pulse No.

Set P1-27 to 0 (rotation number)

Set P1-28 to 1000 (pulse number)

The command of internal position 7: P1-27 Rotation No. + P1-28 Pulse No.

Set P1-29 to -10 (rotation number)

Set P1-30 to 2500 (pulse number)

The command of internal position 8: P1-29 Rotation No. + P1-30 Pulse No.

Input command	Rotation direction
+	CCW
-	CW

STEP 3 :

1. The users can use DI1 to enable the servo drive (Servo ON).
2. Set DI2 (CTRG) to be ON, it indicates the command of internal position 1 (P1-15 Rotation No. + P1-16 Pulse No.) 1 turn is selected, and the motor has rotated one turn at this time.
3. Set DI3 (POS0) to be ON first and then enable DI2 (CTRG) to be ON, it indicates the command of internal position 2 (P1-17 Rotation No. + P1-18 Pulse No.)10 turn is selected, and the motor has rotated ten turns.
4. Set DI3 (POS0), DI4 (POS1) and DI5 (POS2) to be ON first and then enable DI2 (CTRG) to be ON, it indicates the command of internal position 8 (P1-29 Rotation No. + P1-30 Pulse No.)10.25turn is selected, and the motor has rotated 10.25 turns.
5. Repeat the action of (3), (4), (5) freely.
6. When the users want to stop the speed trial run, use DI1 to disable the servo drive (Servo OFF).

Chapter 5 Trial Run and Tuning Procedure | ASDA-A&A+ Series

5.6 Tuning Procedure

Estimate the ratio of Load Inertia to Servo Motor Inertia (J_{load} / J_{motor}): JOG Mode

Tuning Procedure	Display
1. After wiring is completed, when power is connected to the AC servo drive, the right side display will show on the LCD display.	AL14
2. Press MODE key to enter into parameter mode.	P0-00
3. Press SHIFT key twice to select parameter group.	P2-00
4. Press UP key to view each parameter and select parameter P2-17.	P2-17
5. Press SET key to display the parameter value as shown on the right side.	21
6. Press SHIFT key twice, and press UP key. Then, press SET key to display the parameter value as shown on the right side.	121
7. Press UP key to view each parameter and select parameter P2-30.	P2-30
8. Press SET key to display the parameter value as shown on the right side.	0
9. Select parameter value 1. Use UP key to cycle through the available settings.	1
10. Press SET key to write parameter value to the drive, and the right side display will show on the LCD display.	AD-EE
11. At this time, the servo drive is ON and the right side display will appear next.	0
12. Press DOWN key three times to select the ratio of Load Inertia to Servo Motor Inertia (J_{load} / J_{motor}).	JL
13. Display the current ratio of Load Inertia to Servo Motor Inertia (J_{load} / J_{motor}). (5.0 is default setting.)	5.0
14. Press MODE key to select parameter mode.	P2-30
15. Press SHIFT key twice to select parameter group.	P4-00
16. Press UP key to select user parameter P4-05.	P4-05
17. Press SET key and JOG speed 20r/min will be displayed. Press UP and DOWN key to increase and decrease JOG speed. To press SHIFT key one time can add one digit number.	20 ↓ 200
18. Select desired JOG speed, press SET key and it will show the right side display.	JOG
19. Pressing UP key is forward rotation and pressing DOWN key is reverse rotation.	
20. Execute JOG operation in low speed first. After the machine is running smoothly, then execute JOG operation in high speed.	
21. The ratio of Load Inertia to Servo Motor Inertia (J_{load} / J_{motor}) cannot be shown in the display of JOG parameter P4-05 operation. Please press MODE key twice continuously and the users can see the ratio of Load Inertia to Servo Motor Inertia (J_{load} / J_{motor}). Then, execute JOG operation again, press MODE key once and press SET key twice to view the display on the keypad. Check if the value of J_{load} / J_{motor} is adjusted to a fixed value and displayed on the keypad after acceleration and deceleration repeatedly.	

Chapter 5 Trial Run and Tuning Procedure | ASDA-A&A+ Series

5.6.1 Tuning Flowchart

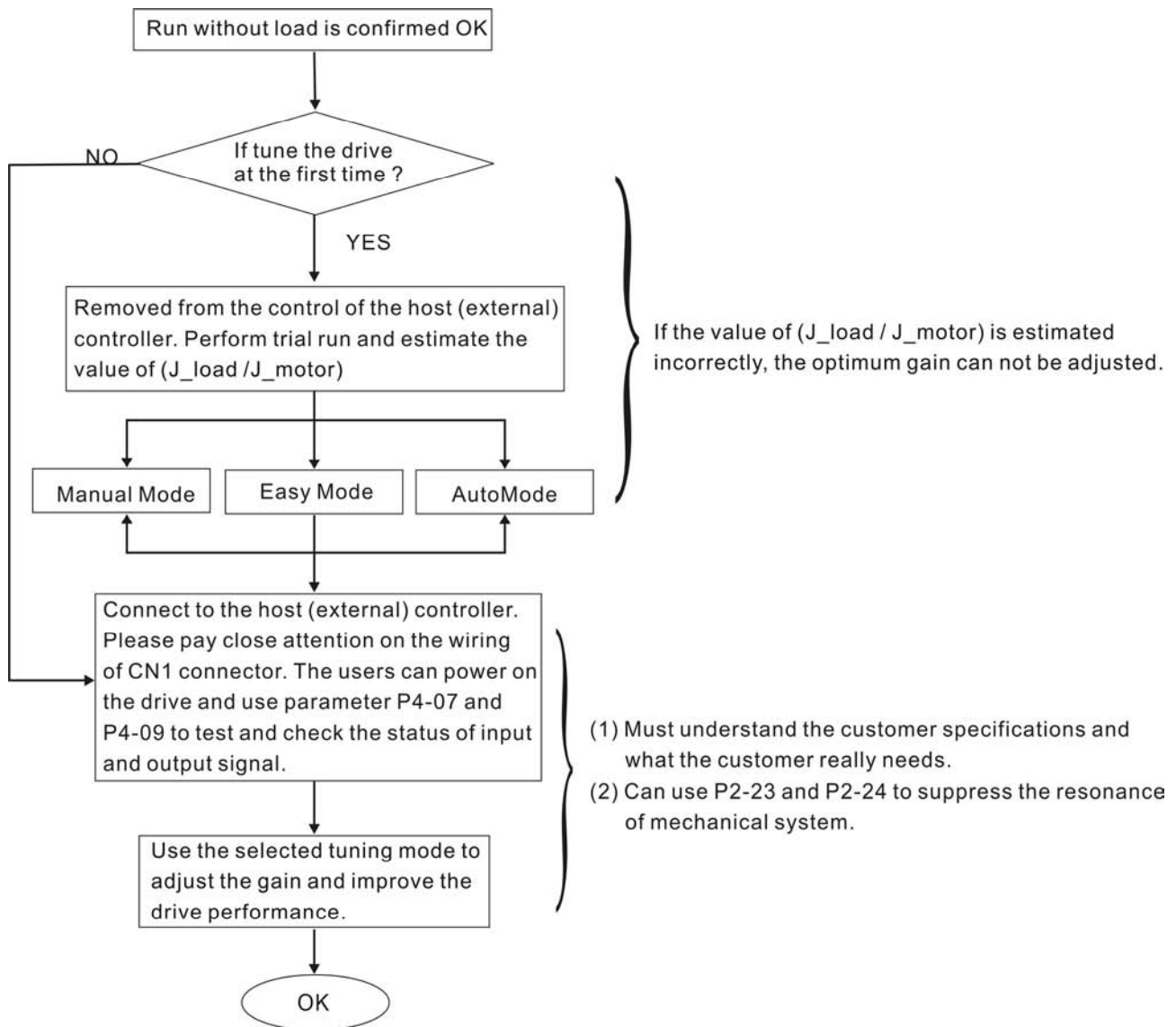

Chapter 5 Trial Run and Tuning Procedure | ASDA-A&A+ Series

5.6.2 Load Inertia Estimation Flowchart

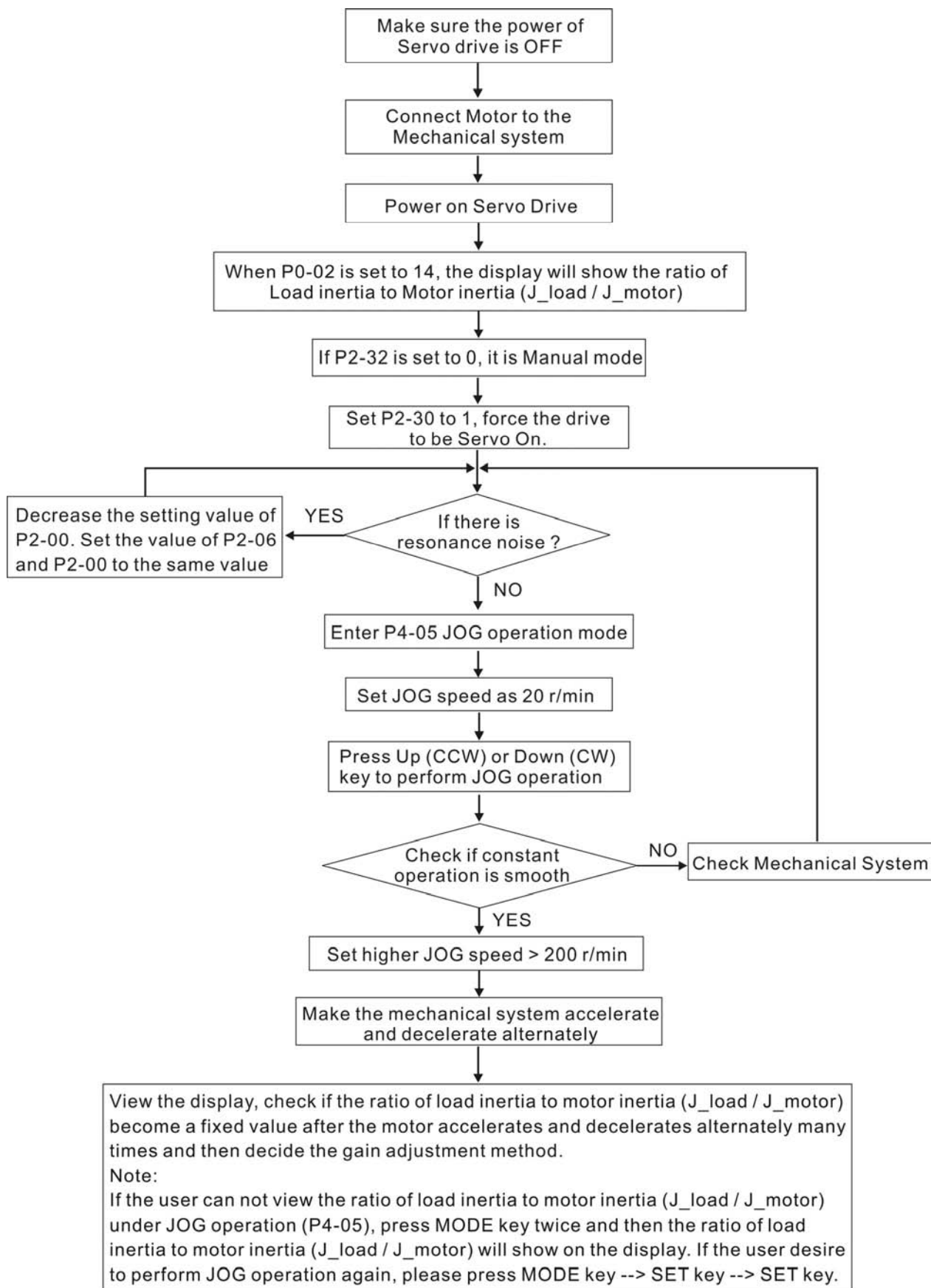

Chapter 5 Trial Run and Tuning Procedure | ASDA-A&A+ Series

5.6.3 Easy Mode Tuning Flowchart

Set P2-31 to 1 (Easy Mode, for ASDA-A series only, ASDA-A+ series does not support this mode)

P2-31 Auto and Easy Mode Selection (Default setting is 4)

Settings:

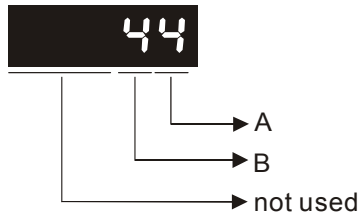

ASDA-A series:

This parameter allows the users to set the stiffness setting of easy mode and the responsiveness level of auto-tuning mode. Users can control the stiffness and responsiveness according to application condition. When the setting value is higher, the stiffness and the responsiveness is higher.

A: Stiffness setting of easy mode

B: Responsiveness level of auto-tuning mode

ASDA-A+ series:

This parameter allows the users to set the responsiveness level setting of auto-tuning mode. Users can control the responsiveness according to application condition. When the setting value is higher, the responsiveness is higher.

A: No function

B: Responsiveness level of auto-tuning mode

In Easy Mode, the value "A" indicates the stiffness setting. When the setting value is higher, the control stiffness is also higher

Adjust P2-31: Increase the setting value of P2-31. Increase the value "A" to add the control stiffness or reduce the noise.

Adjust P2-25: According to the setting value of P2-31 add and adjust the control stiffness.

Continuously adjust until the satisfactory performance is achieved, and then the tuning is completed.

Chapter 5 Trial Run and Tuning Procedure | ASDA-A&A+ Series

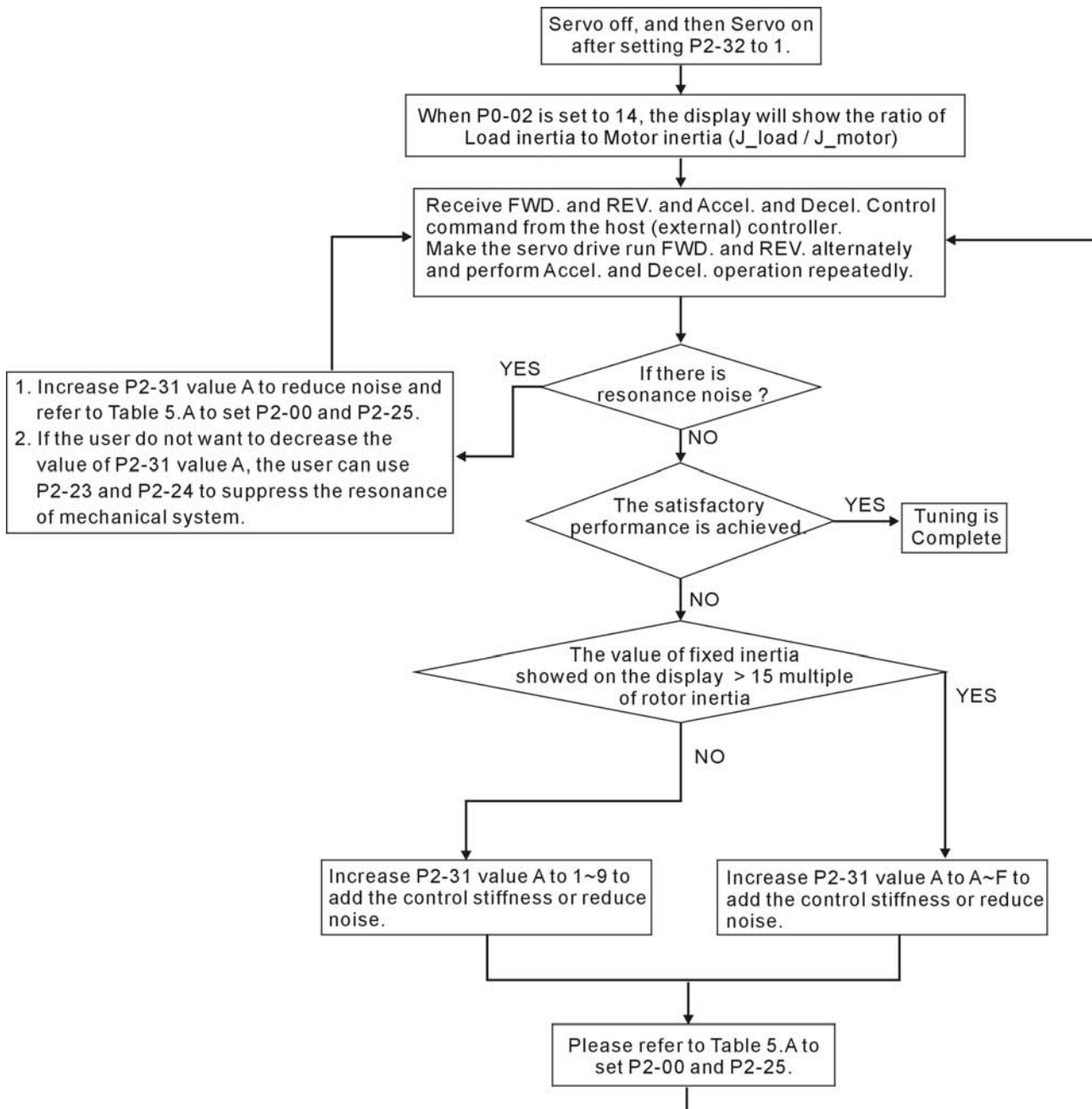

Chapter 5 Trial Run and Tuning Procedure | ASDA-A&A+ Series

Table 5.A Stiffness Setting in Easy Mode (P2-31 value "A") and the setting of P2-00, P2-25

Level (P2-31)	Load Range (J_load /J_motor)	Max. Load Corresponding Responsiveness	KPP (P2-00)	NLP (P2-25)	Remark
Low Responsiveness Level	1	50~100	5Hz	5	The setting of P2-00 and P2-25 must be inputted manually
	2	30~50	8Hz	8	
	3	20~30	11Hz	11	
	4	16~20	15Hz	15	
Medium Responsiveness Level	5	12~16	20Hz	20	The setting of P2-00 and P2-25 must be inputted manually
	6	8~12	27Hz	27	
	7	5~8	40Hz	40	
	8	2~5	60Hz	60	
	9	0~2	115Hz	115	
High Responsiveness Level	A	0~2	127Hz	127	The setting of P2-00 and P2-25 must be inputted manually
	B	2~8	103Hz	103	
	C	8~15	76Hz	76	
	D	15~25	62Hz	62	
	E	25~50	45Hz	45	
	F	50~100	36Hz	36	

Chapter 5 Trial Run and Tuning Procedure | ASDA-A&A+ Series

5.6.4 AutoMode (PI) Tuning Flowchart

Set P2-31 to 2 (AutoMode (PI) [Continuous adjustment])

P2-31 Auto and Easy Mode Selection (Default setting is 4)

Settings:

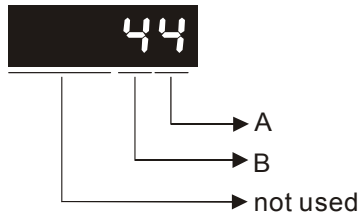

ASDA-A series:

This parameter allows the users to set the stiffness setting of easy mode and the responsiveness level of auto-tuning mode. Users can control the stiffness and responsiveness according to application condition. When the setting value is higher, the stiffness and the responsiveness is higher.

A: Stiffness setting of easy mode

B: Responsiveness level of auto-tuning mode

ASDA-A+ series:

This parameter allows the users to set the responsiveness level setting of auto-tuning mode. Users can control the responsiveness according to application condition. When the setting value is higher, the responsiveness is higher.

A: No function

B: Responsiveness level of auto-tuning mode

In AutoMode (PI), the value “B” indicates the responsiveness setting. When the setting value is higher, the responsiveness is faster.

Adjust P2-31: Increase the setting value of P2-31. Increase the value “B” to speed the responsiveness or reduce the noise.

Adjust P2-25: According to the setting value of P2-31 speed and adjust the responsiveness.

Continuously adjust until the satisfactory performance is achieved, and then the tuning is completed.

Chapter 5 Trial Run and Tuning Procedure | ASDA-A&A+ Series

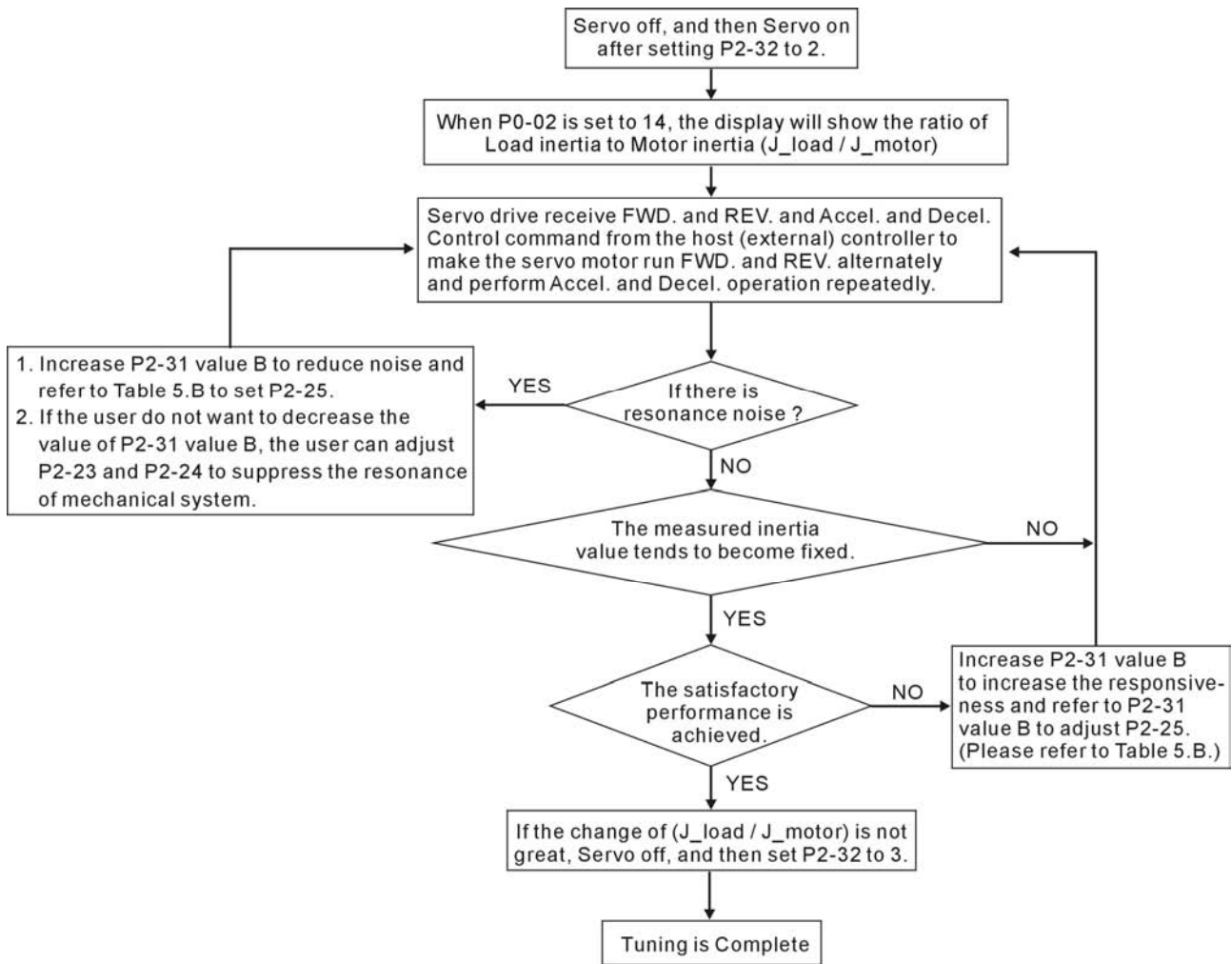

Table 5.B P2-31 Value “B” Setting in AutoMode (PI) and the setting of P2-00, P2-25

P2-31 value “B”	Speed Loop Responsive	Recommended Setting Value of P2-25
0	20Hz	13
1	30Hz	9
2	40Hz	6
3	60Hz	4
4	85Hz	3
5	120Hz	3
6	160Hz	2
7	200Hz	1
8	250Hz	1
9 and above	300Hz	0

Chapter 5 Trial Run and Tuning Procedure | ASDA-A&A+ Series

5.6.5 AutoMode (PDFF) Tuning Flowchart

Set P2-31 to 4 (AutoMode (PDFF) [Continuous adjustment])

P2-31 Auto and Easy Mode Selection (Default setting is 4)

Settings:

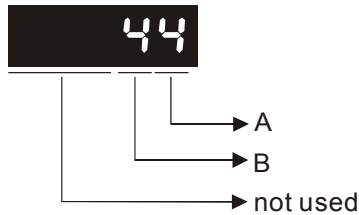

ASDA-A series:

This parameter allows the users to set the stiffness setting of easy mode and the responsiveness level of auto-tuning mode. Users can control the stiffness and responsiveness according to application condition. When the setting value is higher, the stiffness and the responsiveness is higher.

A: Stiffness setting of easy mode

B: Responsiveness level of auto-tuning mode

ASDA-A+ series:

This parameter allows the users to set the responsiveness level setting of auto-tuning mode. Users can control the responsiveness according to application condition. When the setting value is higher, the responsiveness is higher.

A: No function

B: Responsiveness level of auto-tuning mode

In AutoMode (PDFF), the value “B” indicates the responsiveness setting. When the setting value is higher, the responsiveness is faster.

Adjust P2-31: Increase the setting value of P2-31. Increase the value “B” to speed the responsiveness or reduce the noise.

Continuously adjust until the satisfactory performance is achieved, and then the tuning is completed.

Chapter 5 Trial Run and Tuning Procedure | ASDA-A&A+ Series

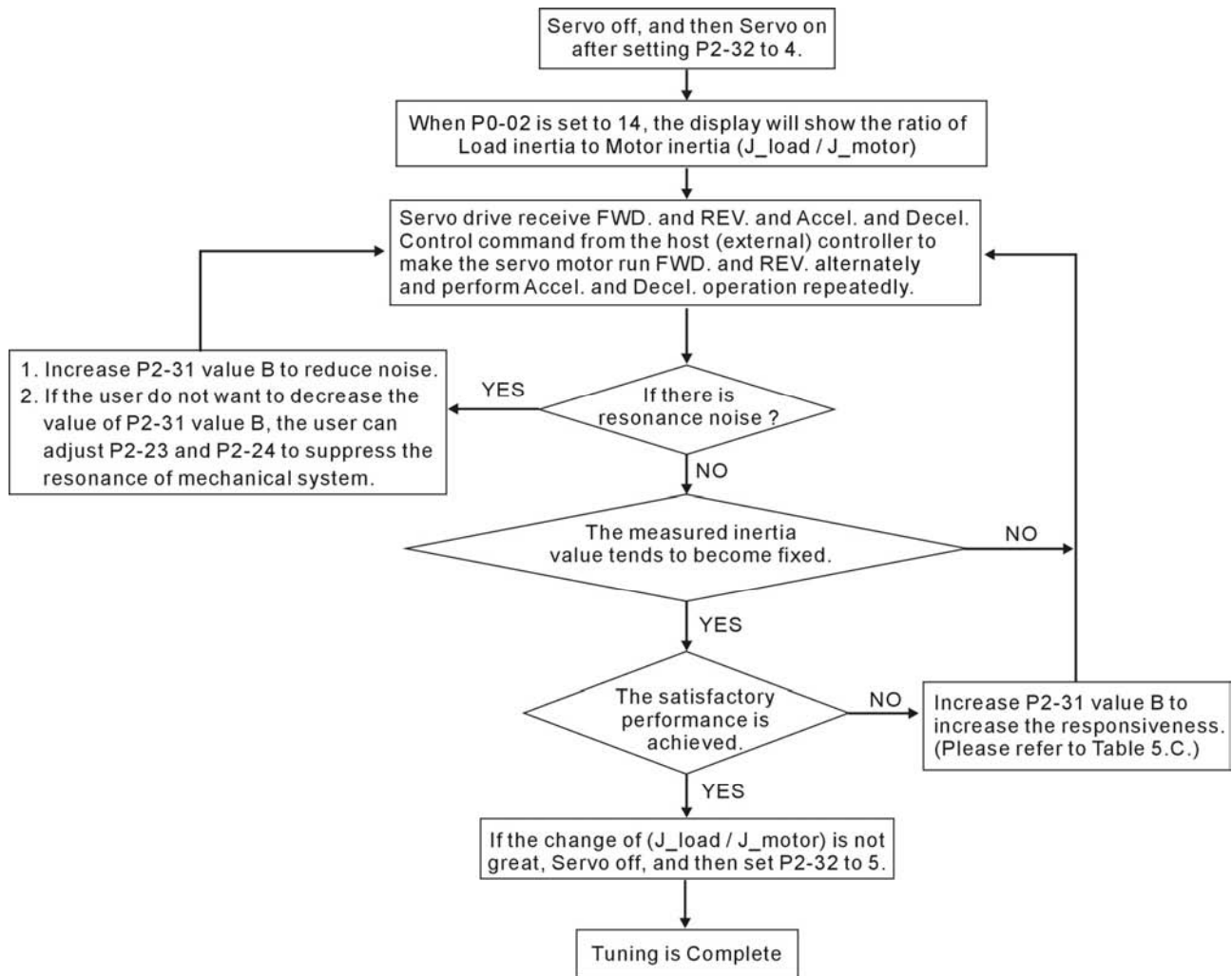

Table 5.C P2-31 Value “B” Setting in AutoMode (PDF) and the Speed Loop Responsiveness.

P2-31 value “B”	Speed Loop Responsiveness	P2-31 value “B”	Speed Loop Responsiveness
0	20HZ	8	120Hz
1	30 HZ	9	140HZ
2	40 HZ	A	160HZ
3	50 HZ	B	180HZ
4	60 HZ	C	200Hz
5	70 Hz	D	220Hz
6	80Hz	E	260Hz
7	100Hz	F	300HZ

Chapter 5 Trial Run and Tuning Procedure | ASDA-A&A+ Series

5.6.6 Limit of Load Inertia Estimation

The accel. / decel. time for reaching 2000r/min must be below 1 second. The rotation speed must be above 200r/min. The load inertia must be 100 multiple or less of motor inertia. The change of external force and the inertia ratio can not be too much. In AutoMode (P2-32 is set to 3 or 5), it will stop estimating the load inertia. The measured load inertia value will not be saved when the power is cut off. When re-apply the power to the drive every time, the setting value of P1-37 is equal to the initial value of load inertia value. But, the measured inertia value will be memorized in P1-37 automatically when:

- (1) Switching AutoMode #2 to AutoMode #3
- (2) Switching AutoMode #4 to AutoMode #5

5.6.7 Relationship between Tuning Modes and Parameters

Tuning Mode	P2-32	AutoSet Parameter	User-defined Parameter	Gain Value
Manual Mode	0 (Default setting)	None	P2-00 (Proportional Position Loop Gain) P2-04 (Proportional Speed Loop Gain) P2-06 (Speed Integral Compensation) P2-25 (Low-pass Filter Time Constant of Resonance Suppression)	Fixed
Easy Mode	1	P2-04 P2-06 P2-26	P2-31 Value A (Level of Stiffness) P2-00 (Proportional Position Loop Gain) P2-25 (Low-pass Filter Time Constant of Resonance Suppression)	Fixed
AutoMode (PI) [Continuous]	2	P2-00 P2-04 P2-06	P2-31 Value B (Level of Responsiveness) P2-25 (Low-pass Filter Time Constant of Resonance Suppression)	Continuous Adjusting
AutoMode (PI) [Fixed Inertia] (The inertia ratio is determined by P1-37)	3	P2-00 P2-04 P2-06	P1-37 (Ratio of Load Inertia to Servo Motor Inertia [J_load / J_motor]) P2-31 Value B (Level of Responsiveness) P2-25 (Low-pass Filter Time Constant of Resonance Suppression)	Fixed
AutoMode (PDFF) [Continuous]	4	P2-00 P2-04 P2-06 P2-25 P2-26	P2-31 Value B (Level of Responsiveness)	Continuous Adjusting
AutoMode (PDFF) [Fixed Inertia] (The inertia ratio is determined by P1-37)	5	P2-00 P2-04 P2-06 P2-25 P2-26	P1-37 (Ratio of Load Inertia to Servo Motor Inertia [J_load / J_motor]) P2-31 Value B (Level of Responsiveness)	Fixed

When switching mode #3 to #0, the setting value of P2-00, P2-04 and P2-06 will change to the value that measured in #3 auto-tuning mode.

Chapter 5 Trial Run and Tuning Procedure | ASDA-A&A+ Series

When switching mode #5 to #0, the setting value of P2-00, P2-04, P2-06, P2-25 and P2-26 will change to the value that measured in #5 auto-tuning mode.

NOTE

- 1) ASDA-A+ series does not support Easy mode.

5.6.8 Gain Adjustment in Manual Mode

The position and speed responsiveness selection is depending on and determined by the the control stiffness of machinery and conditions of applications. Generally, high reponsiveness is essential for the high frequency positioning control of mechanical facilities and the applications of high precision process system. However, the higher responsiveness may easily result in the resonance of machinery system. Therefore, for the applications of high responsiveness, the machinery system with control stiffness is needed to avoid the resonance. Especially when adjusting the responsiveness of unfamiliar machinery system, the users can gradually increase the gain setting value to improve responsiveness untill the resonance occurs, and then decrease the gain setting value. The relevant parameters and gain adjusting methods are described as follows:

- KPP, Parameter P2-00 Proportional Position Loop Gain

This parameter is used to determine the responsiveness of position loop (position loop gain). It could be used to increase stiffness, expedite position loop response and reduce position error. When the setting value of KPP is higher, the response to the position command is quicker, the position error is less and the settling time is also shorter. However, if the setting value is over high, the machinery system may generate vibration or noise, or even overshoot during positioning. The position loop responsiveness is calculated as follows:

$$\text{Position Loop Responsiveness (Hz)} = \frac{KPP}{2\pi}$$

- KVP, Parameter P2-04 Proportional Speed Loop Gain

This parameter is used to determine the responsiveness of speed loop (speed loop gain). It could be used to expedite speed loop response. When the setting value of KVP is higher, the response to the speed command is quicker. However, if the setting value is over high, it may result in the resonance of machinery system. The responsiveness of speed loop must be higher than the 4~6 times of the responsiveness of position loop. If responsiveness of position loop is higher than the responsiveness of speed loop, the machinery system may generate vibration or noise, or even overshoot during positioning. The speed loop responsiveness is calculated as follows:

ASDA-A Series:

$$\text{Speed Loop Responsiveness } f_v = \left(\frac{KVP}{2\pi}\right) \times \frac{1}{(1+JL/JM)} \text{ Hz}$$

Chapter 5 Trial Run and Tuning Procedure | ASDA-A&A+ Series

ASDA-A+ Series:

$$\text{Speed Loop Responsiveness } f_v = \left(\frac{KVP}{2\pi} \right) \times \left[\frac{(1+P1-37/10)}{(1+JL/JM)} \right] \text{Hz}$$

JM: Motor Inertia

JL: Load Inertia

P1-37: 0.1 times

When the value of P1-37 (no matter it is the measured load inertia value or the set load inertia value) is equal to the actual load inertia value, the actual speed loop responsiveness will be:

$$f_v = \frac{KVP}{2\pi} \text{ Hz}$$

■ KVI, Parameter P2-06 Speed Integral Compensation

If the setting value of KVI is higher, the capability of decreasing the speed control deviation is better. However, if the setting value is over high, it may easily result in the vibration of machinery system. The recommended setting value is as follows:

$$\text{KVI (Parameter P2-06)} \leq 1.5 \times \text{Speed Loop Responsiveness}$$

■ NLP, Parameter P2-25 Low-pass Filter Time Constant of Resonance Suppression

When the value of (J_load / J_motor) is high, the responsiveness of speed loop may decrease. At this time, the users can increase the setting value of KVP (P2-04) to keep the responsiveness of speed loop. However, when increasing the setting value of KVP (P2-04), it may easily result in the vibration of machinery system. Please use this parameter to suppress or eliminate the noise of resonance. If the setting value of NLP is higher, the capability of improving the noise of resonance is better. However, if the setting value is over high, it may easily lead to the instability of speed loop and overshoot of machinery system.

The recommended setting value is as follows:

$$\text{NLP (Parameter P2-25)} \leq \frac{1000}{4 \times \text{Speed Loop Responsiveness (Hz)}}$$

■ DST, Parameter P2-26 External Anti-Interference Gain

This parameter is used to enhance the anti-interference capability and reduce the occurrence of overshoot. The default setting is 0 (Disabled). It is not recommended to use it in manual mode only when performing a few tuning on the value gotten through P2-32 AutoMode (PDFF) (setting value is 5, mode 5) automatically (The setting value of P2-26 will change to the value that measured in mode 5 (AutoMode (PDFF)) when switching mode 5 ((AutoMode (PDFF)) to mode 0 (Manual mode)).

■ PFG, Parameter P2-02 Position Feed Forward Gain

This parameter is used to reduce position error and shorten the positioning settling time. However, if the setting value is over high, it may easily lead to the overshoot of machinery system. If the value of electronic gear ratio (1-44 /1-45) is over than 10, the machinery system may also easily generate vibration or noise.

Chapter 6 Control Modes of Operation

6.1 Control Modes of Operation

The Delta ASDA-A and ASDA-A+ series can be programmed to provide six single and five dual modes of operation. Their operation and description is listed in the following table.

Mode		Code	Description
Single Mode	External Position Control	Pt	Position control for the servo motor is achieved via an external pulse command.
	Internal Position Control	Pr	Position control for the servo motor is achieved via by 8 commands stored within the servo controller. Execution of the 8 positions is via Digital Input (DI) signals.
	Speed Control	S	Speed control for the servo motor can be achieved via parameters set within the controller or from an external analog -10 ~ +10 Vdc command. Control of the internal speed parameters is via the Digital Inputs (DI). (A maximum of three speeds can be stored internally).
	Internal Speed Control	Sz	Speed control for the servo motor is only achieved via parameters set within the controller. Control of the internal speed parameters is via the Digital Inputs (DI). (A maximum of three speeds can be stored internally).
	Torque Control	T	Torque control for the servo motor can be achieved via parameters set within the controller or from an external analog -10 ~ +10 Vdc command. Control of the internal torque parameters is via the Digital Inputs (DI). (A maximum of three torque levels can be stored internally).
	Internal Torque Control	Tz	Torque control for the servo motor is only achieved via parameters set within the controller. Control of the internal torque parameters is via the Digital Inputs (DI). (A maximum of three torque levels can be stored internally).
Dual Mode		Pt-S	Either Pt or S control mode can be selected via the Digital Inputs (DI)
		Pt-T	Either Pt or T control mode can be selected via the Digital Inputs (DI)
		Pr-S	Either Pr or S control mode can be selected via the Digital Inputs (DI)
		Pr-T	Either Pr or T control mode can be selected via the Digital Inputs (DI)
		S-T	Either S or T control mode can be selected via the Digital Inputs (DI)

The steps of changing mode:

- (1) Switching the servo drive to Servo Off status. Turning SON signal of digit input to be off can complete this action.
- (2) Using parameter P1-01. (Refer to chapter 7).
- (3) After the setting is completed, cut the power off and restart the drive again.

Chapter 6 Control Modes of Operation | ASDA-A&A+ Series

The following sections describe the operation of each control mode, including control structure, command source and loop gain adjustment, etc.

6.2 Position Control Mode

The position control mode (Pt or Pr mode) is usually used for the applications requiring precision positioning, such as industry positioning machine, indexing table etc. Delta ASDA-A and ASDA-A+ series servo drives support two kinds of command sources in position control mode. One is an external pulse train (Pt: Position Terminals, External Position Control) and the other is internal parameter (Pr: Position Register, i.e. internal parameters P1-15 to P1-30, Internal Position Control). The external pulse train with direction which can control the rotation angle of servo motor. The max. input frequency for the external pulse command is 500Kpps and it is equal to rotation speed of 3000r/min.

In order to provide a convenient position control function, Delta servo drive provides eight internal preset parameters for position control. There are two setting methods of internal parameters, one is to set different position command into these eight internal parameters before operation and then use POS0~POS2 of DI signals of CN1 to perform positioning control. The other setting method is to use serial communication to change the setting value of these eight internal parameters.

To make the servo motor and load operate more smoothly, Delta servo drive also provide complete Position Spine Line (P-curve) profile for position control mode. For the closed-loop positioning, speed control loop is the principal part and the auxiliary parameters are position loop gain and feed forward compensation. The users can also select three kinds of tuning mode (Manual/Auto/Easy modes) to perform gain adjustment. This Section 6.2 mainly describes the applicability of loop gain adjustment and feed forward compensation of Delta servo system.

6.2.1 Command Source of Position (Pt) Control Mode

The command source of P mode is external pulse train input form terminals. There are three types of pulse input and each pulse type is with logic type (positive (+), negative (-)). They all can be set in parameter P1-00. Please refer to the following relevant parameters:

P1 - 00▲	PTT	External Pulse Input Type	Communication Addr.: 0100H
	Default: 2		Related Section:
	Applicable Control Mode: Pt		Section 6.2.1
	Unit: N/A		
	Range: 00 ~ 132 (ASDA-A series)		
	00 ~ 1132 (ASDA-A+ series)		

Chapter 6 Control Modes of Operation | ASDA-A&A+ Series

Settings:

ASDA-A series:

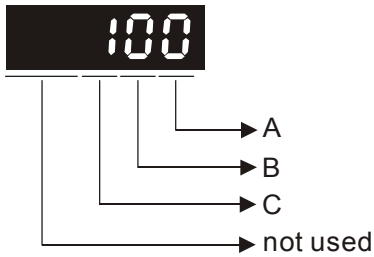

ASDA-A+ series:

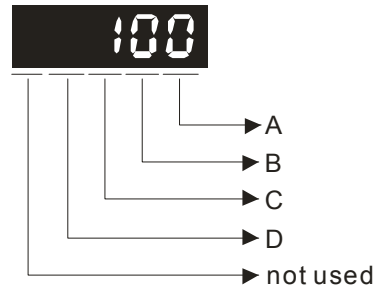

- A: Pulse type
A=0: AB phase pulse (4x)
A=1: CW + CCW pulse
A=2: Pulse + Direction
Other setting: Reversed
- B: Input pulse filter
B=0: 500Kpps
B=1: 200Kpps
B=2: 150Kpps
B=3: 80Kpps

This setting is used to suppress or reduce the chatter caused by the noise, etc. However, if the instant input pulse filter frequency is over high, the frequency that exceeds the setting value will be regarded as noise and filtered.

- C: Logic type

Pulse Type	0=Positive Logic		1=Negative Logic	
	Forward	Reverse	Forward	Reverse
AB phase pulse				
CW + CCW pulse				
Pulse + Direction				

Input pulse interface	Max. input pulse frequency
Line driver	500Kpps
Open collector	200Kpps

Chapter 6 Control Modes of Operation | ASDA-A&A+ Series

- D: Source of pulse command

Setting value	Input pulse interface	Max. input pulse frequency	Remark
0	Line driver	500Kpps	CN1 Terminal Identification: PULSE, /PULSE, SIGN, /SIGN
	Open collector	200Kpps	
1	Line driver for high-speed pulse	4Mpps	CN1 Terminal Identification: HPULSE, /HPULSE, HSIGN, /HSIGN



- 1) High-speed pulse function (max. input pulse frequency 4Mpps) is for ASDA-A+ only.

Position pulse can be input from these terminals, PULSE (41), /PULSE (43) and SIGN (37), /SIGN (36). It can be an open-collector circuit or line driver circuit. For the detail wiring, please refer to 3.6.1.

6.2.2 Command Source of Position (Pr) Control Mode

The command sources of Pr mode are P1-15, P1-16 to P1-29, P1-30 these eight built-in parameters. According to parameter P1-33, the users can select: a) Absolute or b) Incremental position control. Using with external I/O signals (CN1, POS 0 to POS 2 and CTRG) can select one of the eight built-in parameters to be position command. Please refer to the table below:

Position Command	POS2	POS1	POS0	CTRG	Parameters	Description	Moving Speed Register
P1	0	0	0	↑	P1-15	Rotation number (+/- 30000)	P2-36 (V1)
					P1-16	Pulses (+/- max cnt)	
P2	0	0	1	↑	P1-17	Rotation number (+/- 30000)	P2-37 (V2)
					P1-18	Pulses (+/- max cnt)	
P3	0	1	0	↑	P1-19	Rotation number (+/- 30000)	P2-38 (V3)
					P1-20	Pulses (+/- max cnt)	
P4	0	1	1	↑	P1-21	Rotation number (+/- 30000)	P2-39 (V4)
					P1-22	Pulses (+/- max cnt)	
P5	1	0	0	↑	P1-23	Rotation number (+/- 30000)	P2-40 (V5)
					P1-24	Pulses (+/- max cnt)	
P6	1	0	1	↑	P1-25	Rotation number (+/- 30000)	P2-41 (V6)
					P1-26	Pulses (+/- max cnt)	
P7	1	1	0	↑	P1-27	Rotation number (+/- 30000)	P2-42 (V7)
					P1-28	Pulses (+/- max cnt)	
P8	1	1	1	↑	P1-29	Rotation number (+/- 30000)	P2-43 (V8)
					P1-30	Pulses (+/- max cnt)	

State of POS0~2: 0 indicates the contact is OFF (Normally Open)

1 indicates the contact is ON (Normally Closed)

Chapter 6 Control Modes of Operation | ASDA-A&A+ Series

CTRGT↑: the instant time when the contact changes from 0 (open) to 1 (closed).

The application of absolute and incremental position control is various and multiple. This kind of position control is equal to a simple sequence control. Users can easily complete the cycle running by using the above table. For example, the position command, P1 is 10 turns and P2 is 20 turns. Give the position command P1 first and then give the position command P2. The difference between absolute and incremental position control is shown as the figure below:

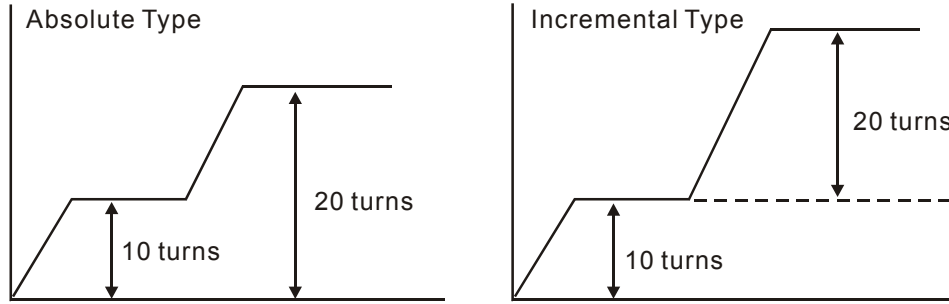

6.2.3 Structure of Position Control Mode

Basic Structure:

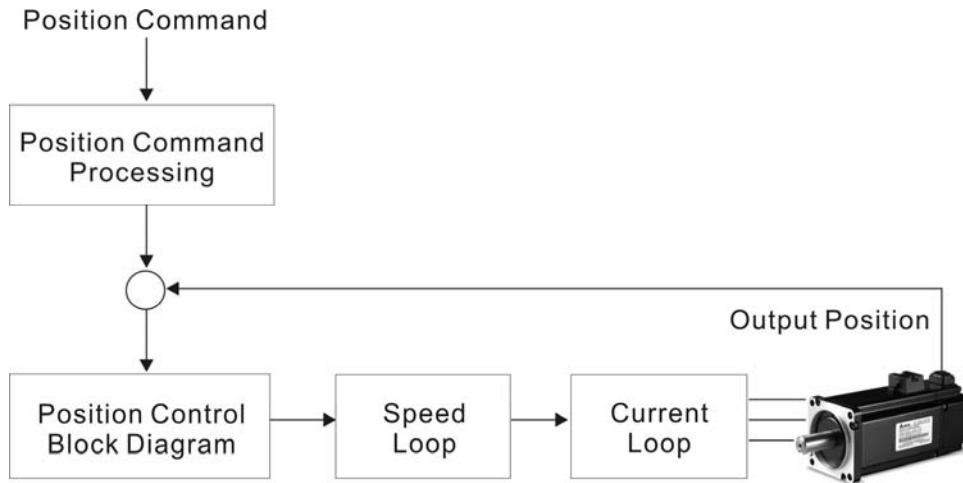

In order to pursue the goal of perfection in position control, the pulse signal should be modified through position command processing and the structure is shown as the figure below:

ASDA-A Series:

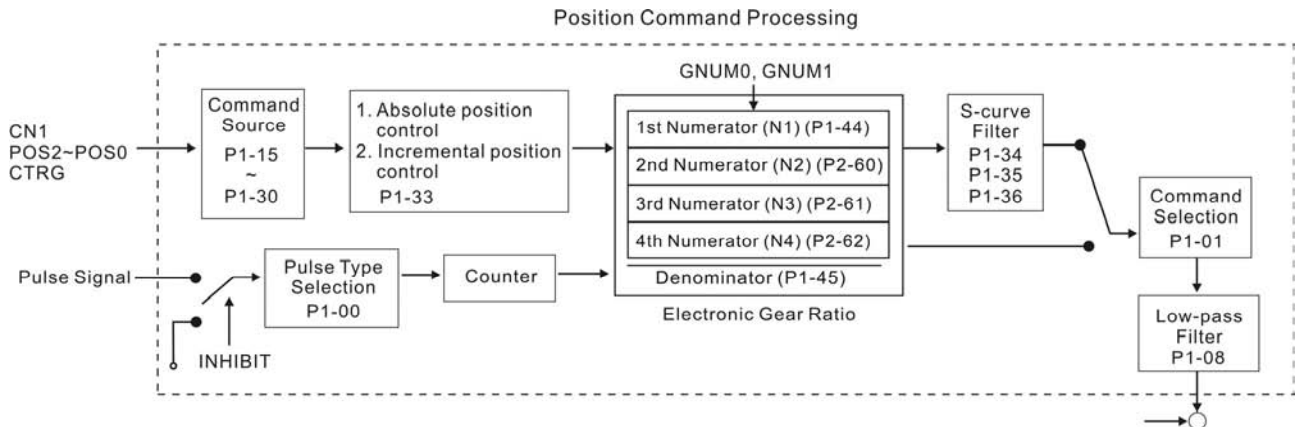

Chapter 6 Control Modes of Operation | ASDA-A&A+ Series

ASDA-A+ Series:

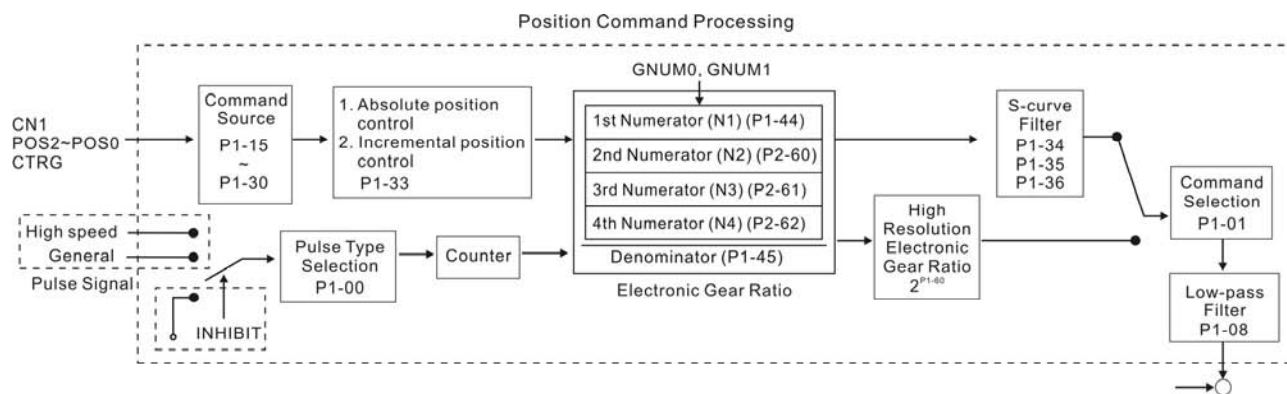

Using parameter can select Pr mode and Pt mode. Electronic gear ratio can be set in both two modes to set proper position revolution. ASDA-A and ASDA-A+ series servo drives also provide S-curve and low-pass filter, which are used whenever the motor and load need to be operated more smoothly. As for the information of electronic gear ratio, S-curve and low-pass filter, please refer to the following sections 6.2.4, 6.2.5 and 6.2.6.

Pulse Inhibit Input Function (INHIBIT)

This function is activated via digital inputs (Please refer to parameter P2-10 ~ P2-17 and DI INHP in Table 7.A). When the drive is in position mode, if INHP is activated, the external pulse input command is not valid and the motor will stop.

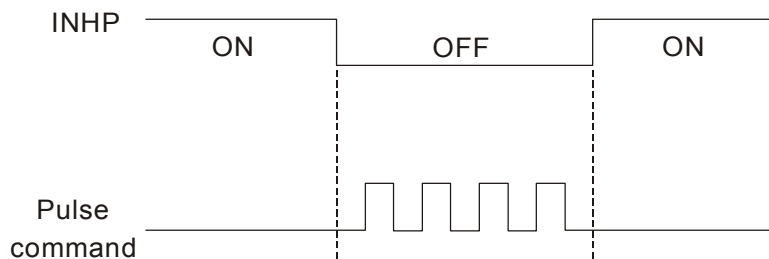

6.2.4 S-curve Filter for Position Control

The S-curve filter is for the position smoothing of motion command. Using S-curve filter can run the servo motor more smoothly in response to a sudden position command. Since the speed and acceleration curve are both continuous and the time for the servo motor to accelerate is short, using S-curve filter not only can improve the performance when servo motor accelerate or decelerate but also can make motor to operate more smoothly (from mechanical view). When the load is change, the motor usually run not smoothly when starts to run and stop due to the friction and inertia change. At this moment, users can increase Accel/Decel S-curve constant (TSL), Accel time constant (TACC) and Decel time constant (TDEC) to improve the performance. Because the speed and angle acceleration are continuous when position command is changed to pulse signal input, so it is not needed to use S-curve filter.

Chapter 6 Control Modes of Operation | ASDA-A&A+ Series

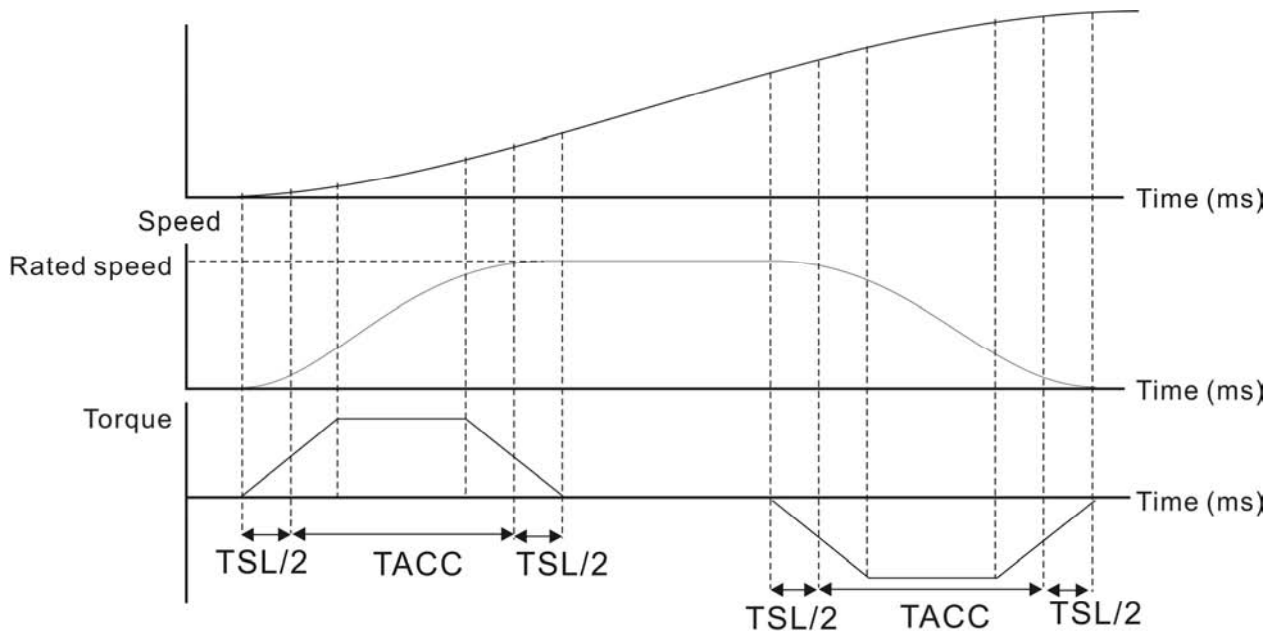

S-curve characteristics and Time relationship (Acceleration)

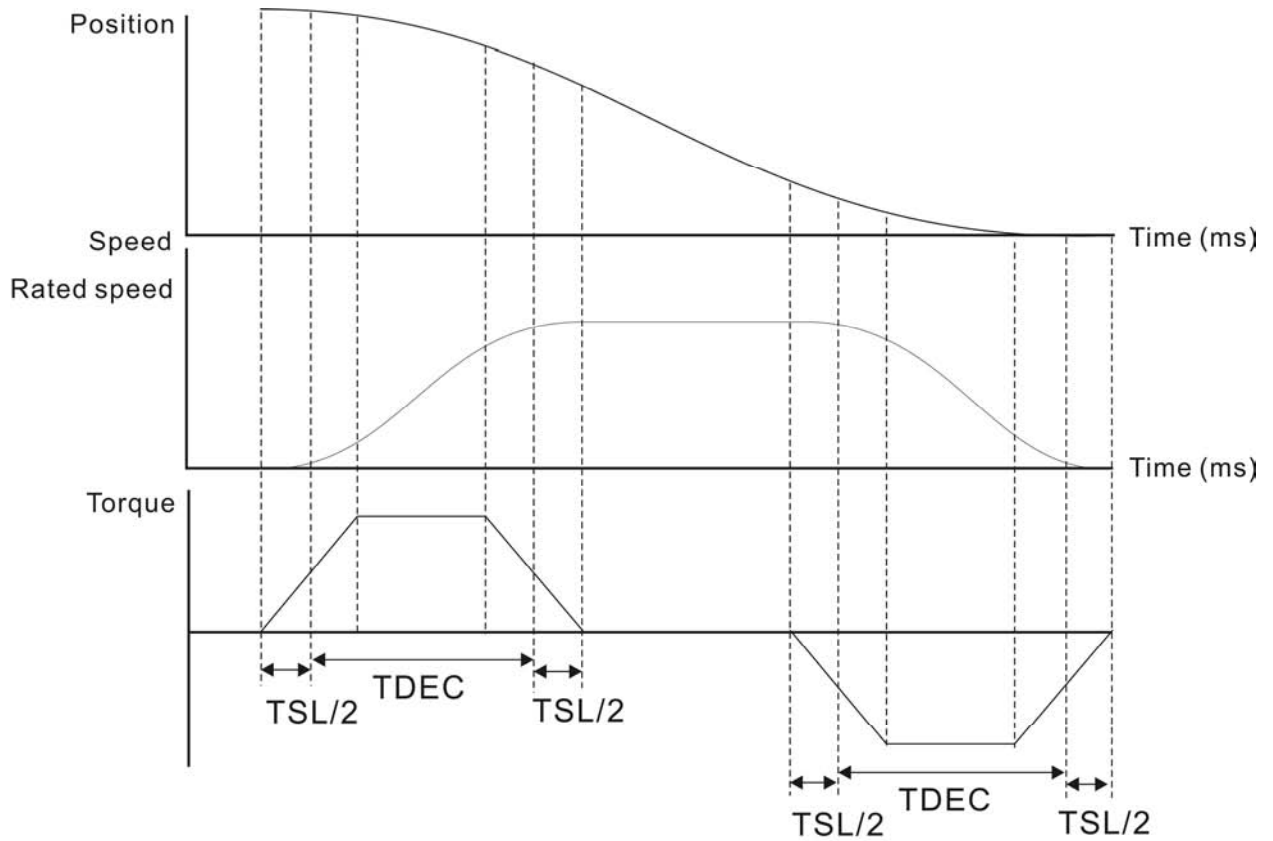

S-curve characteristics and Time relationship (Deceleration)

Chapter 6 Control Modes of Operation | ASDA-A&A+ Series

Relevant parameters:

P1 - 34	TACC	Acceleration Time	Communication Addr.: 0122H
----------------	-------------	--------------------------	-----------------------------------

Default: 200

Related Section:

Applicable Control Mode: Pr, S

P1-35, P1-36, Section 6.3.3

Unit: ms

Range: 1 ~ 20000

Settings:

1st to 3rd step acceleration time.

It is used to determine the acceleration time to accelerate from 0 to its rated motor speed. (When P1-36 is set to 0: Accel/Decel function is disabled, i.e. P1-34, P1-35 is disabled.)

P1 - 35	TDEC	Deceleration Time	Communication Addr.: 0123H
----------------	-------------	--------------------------	-----------------------------------

Default: 200

Related Section:

Applicable Control Mode: Pr, S

P1-34, P1-36, Section 6.3.3

Unit: ms

Range: 1 ~ 20000

Settings:

1st to 3rd step deceleration time.

It is used to determine the deceleration time to decelerate from its rated motor speed to 0. (When P1-36 is set to 0: Accel/Decel function is disabled, i.e. P1-34, P1-35 is disabled.)

P1 - 36	TSL	Accel /Decel S-curve	Communication Addr.: 0124H
----------------	------------	-----------------------------	-----------------------------------

Pr mode Default: 20 (See Note 2)

Related Section:

Other mode Default: 0

P1-34, P1-35,

Unit: ms

Section 6.2.4 (Pr mode),

Range: 0 ~ 10000 (0: Disabled)

Section 6.3.3 (S mode)

Settings:

This parameter is used to make the motor run more smoothly when startup and windup.

Using this parameter can improve the motor running stability.

Speed

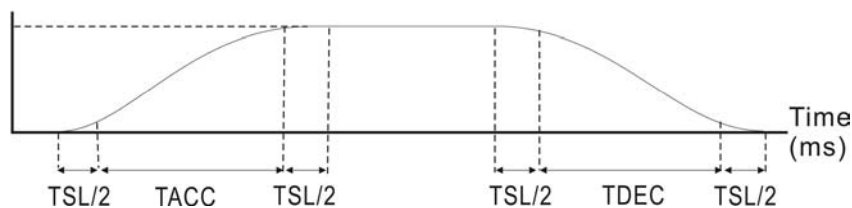

TSL: P1-36, Accel /Decel S-curve

TACC: P1-34, Acceleration time

TDEC: P1-35, Deceleration time

Chapter 6 Control Modes of Operation | ASDA-A&A+ Series

Total acceleration time = TACC + TSL

Total deceleration time = TDEC + TSL



- 1) If the control of the servo motor is achieved via internal parameters, the command curve should be defined by the users. Therefore, when the command source is internal parameter, ensure that the setting value of P1-36 is not set to 0 or the servo motor will not accelerate or decelerate during operation.
- 2) So if users change the control mode to Pr mode and switching power off and on, the servo drive of parameter P1-36 will auto set the value to 20.

6.2.5 Electronic Gear Ratio

Relevant parameters:

P1 - 44▲	GR1	Electronic Gear Ratio (1st Numerator) (N1)	Communication Addr.: 012CH
-----------------	------------	---	-----------------------------------

Default: 1

Related Section:

Applicable Control Mode: Pt, Pr

Section 6.2.5

Unit: pulse

Range: 1 ~ 32767

Settings:

Multiple-step electronic gear numerator setting. Please refer to P2-60~P2-62.

P1 - 45▲	GR2	Electronic Gear Ratio (Denominator)	Communication Addr.: 012DH
-----------------	------------	--	-----------------------------------

Default: 1

Related Section:

Applicable Control Mode: Pt, Pr

Section 6.2.5

Unit: pulse

Range: 1 ~ 32767

Settings:

Electronic gear denominator setting.

Please set electronic gear ratio when the servo drive is Off. As the wrong setting may cause motor to run chaotically (out of control) and it may lead to personnel injury, therefore, ensure to observe the following rule when setting P1-44, P1-45.

The electronic gear ratio setting (Please also see P1-44, P2-60 ~ P2-62):

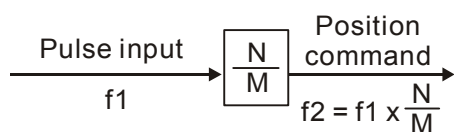

f1: Pulse input

f2: Position command

N: Numerator 1, 2, 3, 4, the setting value of P1-44 or P2-60 ~ P2-63

M: Denominator, the setting value of P1-45

The electronic gear ratio setting range must be within: $1/50 < N/M < 200$.

Chapter 6 Control Modes of Operation | ASDA-A&A+ Series

The electronic gear function provides easy travel distance ratio change. However, the over high electronic gear ratio will command the motor to move not smoothly. At this time, the users can use low-pass filter parameter to improve this kind of situation. For example, assume that the electronic gear ratio is equal to 1 and the encoder pulse per revolution is 10000ppr, if the electronic gear ratio is changed to 0.5, then the motor will rotate one pulse when the command from external controller is two pulses.

For example, after the proper electronic gear ratio is set, the reference travel distance is 1 $\mu\text{m}/\text{pulse}$, the machinery will become easier to be used.

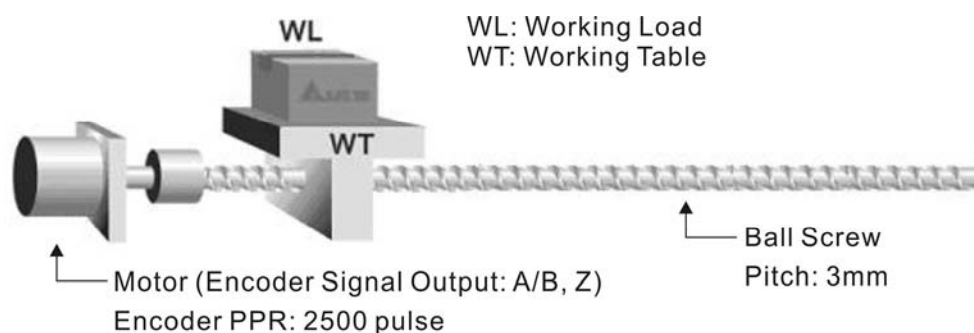

	Electronic Gear Ratio	Corresponding travel distance per pulse
When the electronic gear ratio is not used	$= \frac{1}{1}$	$= \frac{3 \times 1000}{4 \times 2500} = \frac{3000}{10000} \mu\text{m}$
When the electronic gear ratio is not used	$= \frac{10000}{3000}$	$= 1 \mu\text{m}$

6.2.6 Low-pass Filter

Relevant parameters:

P1 - 08	PFLT	Smooth Constant of Position Command (Low-pass Filter)	Communication Addr.: 0108H
----------------	-------------	--	-----------------------------------

Default: 0

Related Section:

Applicable Control Mode: Pt

Section 6.2.6

Unit: 10ms

Range: 0 ~ 1000 (0: Disabled)

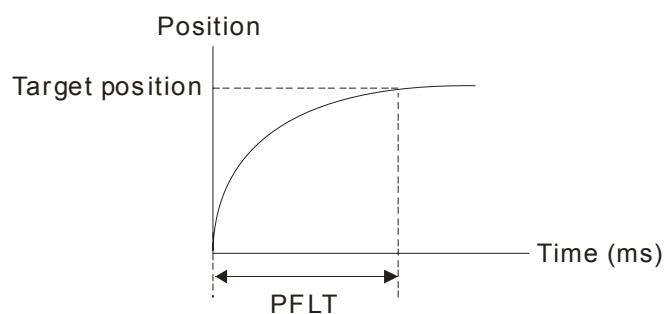

Chapter 6 Control Modes of Operation | ASDA-A&A+ Series

6.2.7 Timing Chart of Position (Pr) Control Mode

In Pr mode, position command source is DI signal from CN1, i.e. selected by POS0~POS2 and CTRG. Please refer to 6-2-2 to see the relationship between DI signals and parameters. The following figure is shown the timing chart of Pr mode:

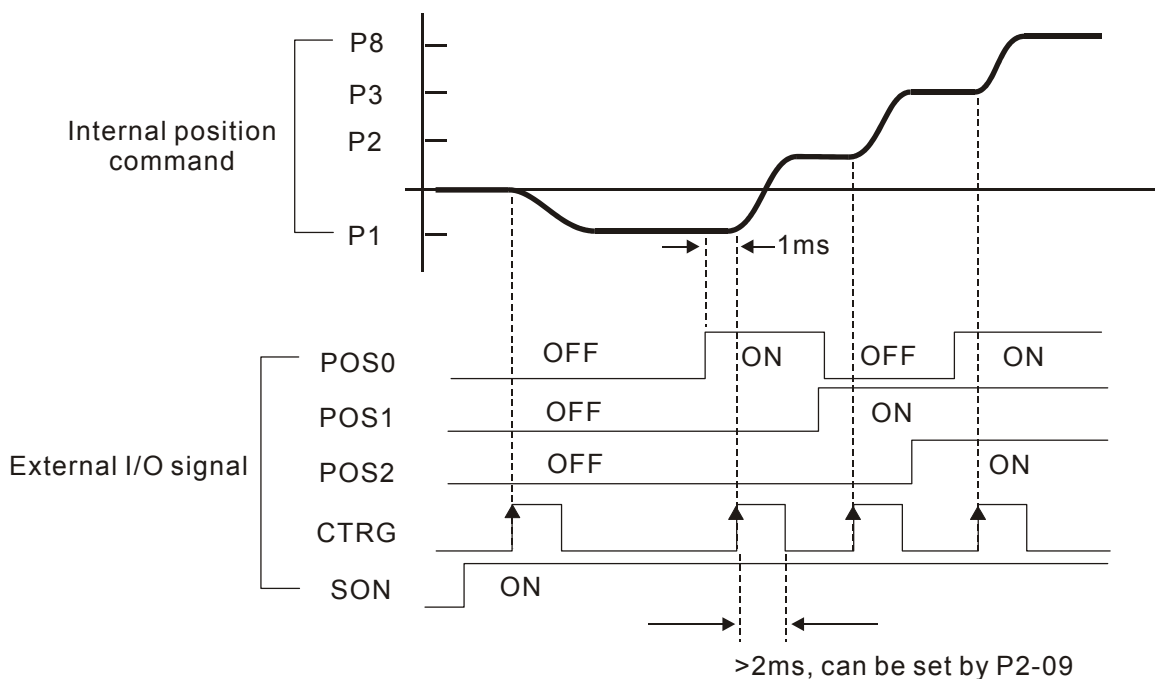

6.2.8 Position Loop Gain Adjustment

Before performing position control (setting position control block diagram), the users should complete the speed control setting by using Manual mode (parameter P-32) since the position loop contains speed loop. Then, adjust the Proportional Position Loop Gain, KPP (parameter P2-00) and Position Feed Forward Gain, PFG (parameter P2-02). Or use Auto mode to adjust the gain of speed and position control block diagram automatically.

- 1) Proportional Position Loop Gain: To increase this gain can enhance the position loop responsiveness.
- 2) Position Feed Forward Gain: To increase this gain can reduce the position track error during operation.

The position loop responsiveness cannot exceed the speed loop responsiveness, and it is recommended that the speed loop responsiveness should be at least four times faster than the position loop responsiveness. This also means that the setting value of Proportional Speed Loop Gain, KVP should be at least four times faster than Proportional Position Loop Gain, KPP.

The equation is shown as follows:

$$f_p \leq \frac{f_v}{4}, \quad f_v : \text{Speed Loop Responsiveness (Hz)}, \quad f_p : \text{Position Loop Responsiveness (Hz)}$$

$$KPP = 2 \times \pi \times f_p.$$

Chapter 6 Control Modes of Operation | ASDA-A&A+ Series

For example, the desired position loop responsiveness is equal to 20 Hz.

Then, $KPP = 2 \times \pi \times 20 = 125 \text{ rad/s}$.

Relevant parameters:

P2 - 00	KPP	Proportional Position Loop Gain	Communication Addr.: 0200H
----------------	------------	--	-----------------------------------

Default: 35

Related Section:

Applicable Control Mode: Pt, Pr

Section 6.2.8

Unit: rad/s

Range: 0 ~ 1023

Settings:

This parameter is used to set the position loop gain. It can increase stiffness, expedite position loop response and reduce position error. However, if the setting value is over high, it may generate vibration or noise.

P2 - 02	PFG	Position Feed Forward Gain	Communication Addr.: 0202H
----------------	------------	-----------------------------------	-----------------------------------

Default: 5000

Related Section:

Applicable Control Mode: Pt, Pr

Section 6.2.8

Unit: 0.0001

Range: 10 ~ 20000

Settings:

This parameter is used to set the feed forward gain when executing position control command. When using position smooth command, increase gain can improve position track deviation. When not using position smooth command, decrease gain can improve the resonance condition of mechanical system. However, if the setting value is over high, it may generate vibration or noise.

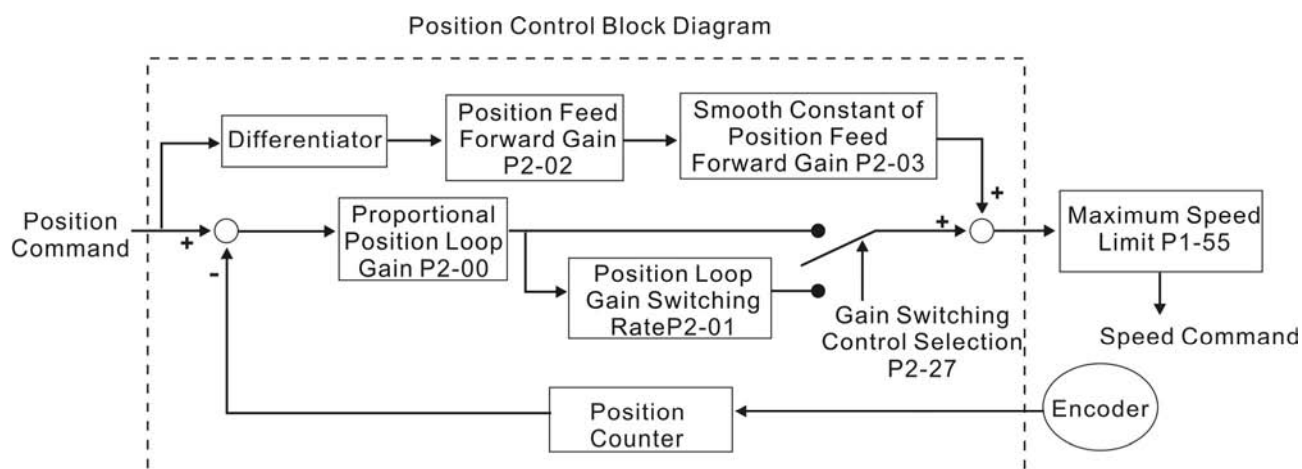

Chapter 6 Control Modes of Operation | ASDA-A&A+ Series

When the value of Proportional Position Loop Gain, KPP is too great, the position loop responsiveness will be increased and it will result in small phase margin. If this happens, the rotor of motor will oscillate. At this time, the users have to decrease the value of KPP until the rotor of motor stop oscillating. When there is an external torque command interrupted, over low KPP value will let the motor cannot overcome the external strength and fail to meet the requirement of reasonable position track error demand. Adjust feed forward gain, PFG (P2-02) to efficiently reduce the dynamic position track error.

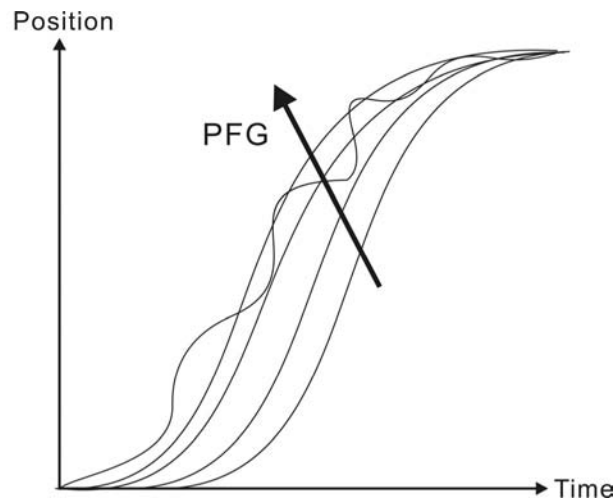
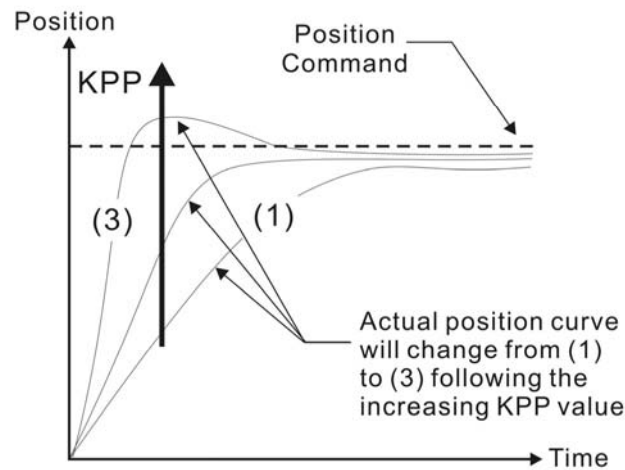

Chapter 6 Control Modes of Operation | ASDA-A&A+ Series

6.3 Speed Control Mode

The speed control mode (S or Sz) is usually used on the applications of precision speed control, such as CNC machine, etc. ASDA-A and ASDA-A+ series servo drives support two kinds of command sources in speed control mode. One is external analog signal and the other is internal parameter. The external analog signal is from external voltage input and it can control the speed of servo motor. There are two usage of internal parameter, one is set different speed command in three speed control parameters before operation and then using SPD0 and SPD1 of CN1 DI signal perform switching. The other usage is using serial communication to change the setting value of parameter.

Beside, in order to make the speed command switch more smoothly, ASDA-A and ASDA-A+ series servo drives also provide complete S-curve profile for speed control mode. For the closed-loop speed control, ASDA-A and ASDA-A+ series servo drives provide gain adjustment function and an integrated PI or PDFF controller. Besides, three modes of tuning technology (Manual/Auto/Easy) are also provided for the users to select (parameter P2-32).

There are three turning modes for gain adjustment: Manual, Auto and Easy modes.

- **Manual Mode:** User-defined loop gain adjustment. When using this mode, all auto and auxiliary function will be disabled.
- **Auto Mode:** Continuous adjustment of loop gains according to measured inertia, with ten levels of system bandwidth. The parameter set by user is default value.
- **Easy Mode:** Robust for wide range of external load inertia change, with ten levels of system stiffness. Using easy mode can immediately suppress the interference of external load and mechanical resonance and also stand for the load inertia change.

6.3.1 Command Source of Speed Control Mode

Speed command Sources:

- 1) External analog signal: External analog voltage input, -10V to +10V
- 2) Internal parameter: P1-09 to P1-11

Speed Command	CN1 DI signal		Command Source		Content	Range
	SPD1	SPD0				
S1	0	0	Mode	S	Voltage between V-REF-GND	+/- 10 V
				Sz	N/A	Speed command is 0
S2	0	1	Internal parameter		P1-09	+/- 5000r/min
S3	1	0			P1-10	+/- 5000r/min
S4	1	1			P1-11	+/- 5000r/min

- State of SPD0~1: 0: indicates OFF (Normally Open); 1: indicates ON (Normally Closed)
- When SPD0 and SPD1 are both = 0 (OFF), if the control mode of operation is Sz, then the speed command is 0. Therefore, if the users do not use analog voltage as speed command, the

Chapter 6 Control Modes of Operation | ASDA-A&A+ Series

users can choose Sz mode and avoid the zero point drift problem of analog voltage signal. If the speed control mode is S mode, then the command is the analog voltage between V-REF and GND. The setting range of the input voltage is from -10V to +10V and the corresponding motor speed is adjustable (Please see parameter P1-40).

- When at least one of SPD0 and SPD1 is not 0 (OFF), the speed command is internal parameter (P1-09 to P1-11). The command is valid (enabled) after either SPD0 or SPD1 is changed.

The speed command that is described in this section not only can be taken as speed command in speed control mode (S or Sz mode) but also can be the speed limit input command in torque control mode (T or Tz mode).

6.3.2 Structure of Speed Control Mode

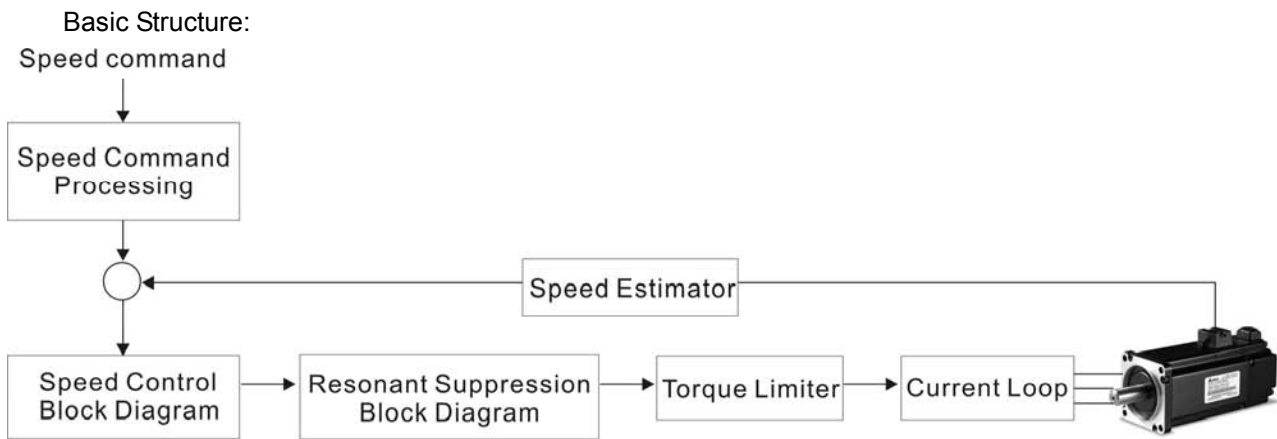

In the figure above, the speed command processing is used to select the command source of speed control according to chapter 6.3.1, including proportional gain (P1-40) and S-curve filter smoothing strategy of speed control. The speed control block diagram is used to manage the gain parameters of the servo drive and calculate the current input provided to motor instantaneously. The resonance suppression block diagram is used to suppress the resonance of mechanical system.

The function and structure of speed command processing is shown as the figure below:

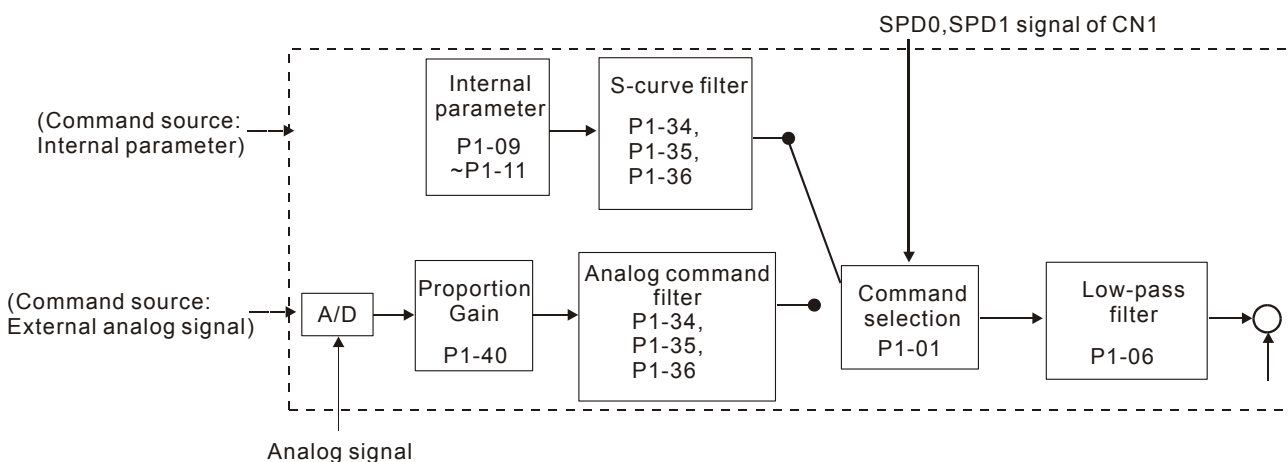

The command source is selected according to the state of SPD0, SPD1 and parameter P1-01 (S or Sz). Whenever the command signal needs to be more smoothly, we recommend the users to use S-curve and low-pass filter.

Chapter 6 Control Modes of Operation | ASDA-A&A+ Series

6.3.3 Smoothing Strategy of Speed Control Mode

S-curve Filter

The S-curve filter is a speed smoothing command which provides 3 steps accel / decel S-curve to smooth the speed command change of the motor during acceleration and deceleration. Using S-curve filter can let the servo motor run more smoothly in response to a sudden speed command change. Since the speed and acceleration curve are both continuous, in order to avoid the mechanical resonance and noise may occur due to a sudden speed command (differentiation of acceleration), using S-curve filter not only can improve the performance when servo motor accelerate or decelerate but also can make the motor run more smoothly. S-curve filter parameters include P1-34 Acceleration Time (TACC), P1-35 Deceleration Time (TDEC) and Accel /Decel S-curve (TSL), and the users can use these three parameters to improve the motor performance during acceleration, deceleration and operation. ASDA-A and ASDA-A+ series servo drives also support the time calculation of completing speed command. T (ms) is the operation (running) time. S (r/min) is absolute speed command, i.e. the absolute value (the result) after starting speed subtracts the final speed.

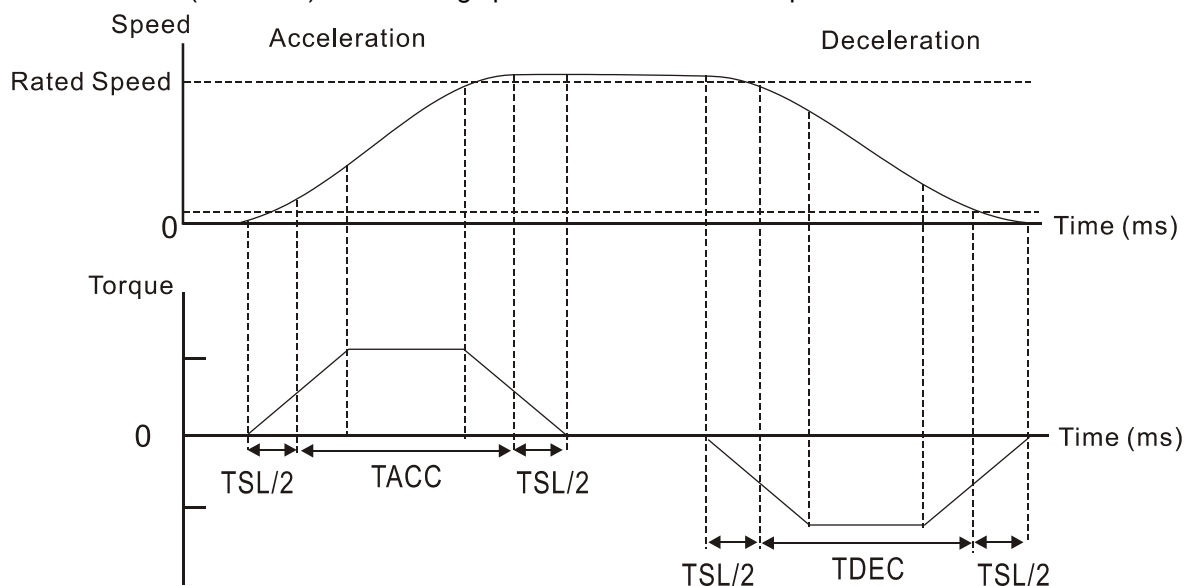

S-curve characteristics and Time relationship

Relevant parameters:

P1 - 34	TACC	Acceleration Time	Communication Addr.: 0122H
----------------	-------------	--------------------------	-----------------------------------

Default: 200

Applicable Control Mode: Pr, S

Unit: ms

Range: 1 ~ 20000

Settings:

1st to 3rd step acceleration time.

It is used to determine the acceleration time to accelerate from 0 to its rated motor speed. (When P1-36 is set to 0: Accel/Decel function is disabled, i.e. P1-34, P1-35 is disabled.)

Related Section:

P1-35, P1-36, Section 6.3.3

Chapter 6 Control Modes of Operation | ASDA-A&A+ Series

P1 - 35**TDEC****Deceleration Time****Communication Addr.: 0123H**

Default: 200

Applicable Control Mode: Pr, S

Unit: ms

Range: 1 ~ 20000

Settings:

1st to 3rd step deceleration time.

It is used to determine the deceleration time to decelerate from its rated motor speed to 0.

(When P1-36 is set to 0: Accel/Decel function is disabled, i.e. P1-34, P1-35 is disabled.)

Related Section:

P1-34, P1-36, Section 6.3.3

P1 - 36**TSL****Accel /Decel S-curve****Communication Addr.: 0124H**

Pr mode Default: 20 (See Note 2)

Other mode Default: 0

Unit: ms

Range: 0 ~ 10000 (0: Disabled)

Settings:

This parameter is used to make the motor run more smoothly when startup and windup.

Using this parameter can improve the motor running stability.

Speed

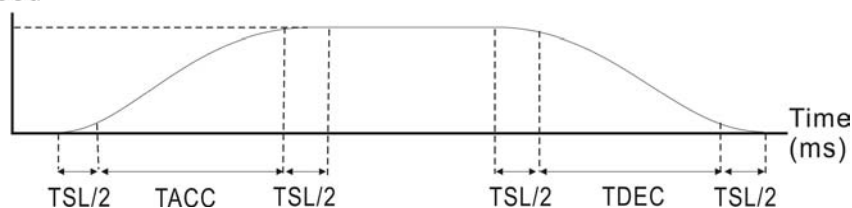

TSL: P1-36, Accel /Decel S-curve

TACC: P1-34, Acceleration time

TDEC: P1-35, Deceleration time

Total acceleration time = TACC + TSL

Total deceleration time = TDEC + TSL



- 1) If the control of the servo motor is achieved via internal parameters, the command curve should be defined by the users. Therefore, when the command source is internal parameter, ensure that the setting value of P1-36 is not set to 0 or the servo motor will not accelerate or decelerate during operation.
- 2) So if users change the control mode to Pr mode and switching power off and on, the servo drive of parameter P1-36 will auto set the value to 20.

Chapter 6 Control Modes of Operation | ASDA-A&A+ Series

Analog Speed Command S-curve Filter

ASDA-A and ASDA-A+ series servo drives also provide Analog Speed Command S-curve Filter for the smoothing in response to a sudden analog input signal.

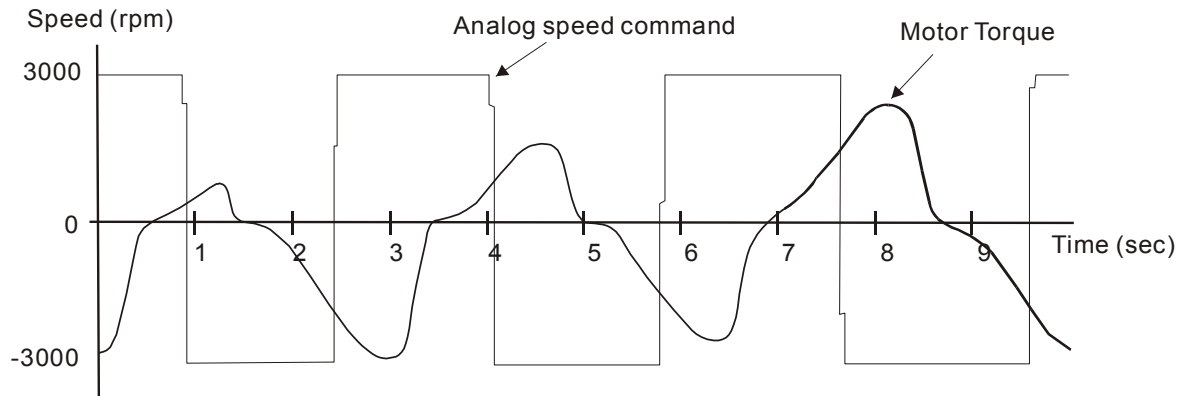

The analog speed command S-curve filter is for the smoothing of analog input signal and its function is the same as the S-curve filter. The speed and acceleration curve of analog speed command S-curve filter are both continuous. The above figure shows the curve of analog speed command S-curve filter and the users can see the ramp of speed command is different during acceleration and deceleration. Also, the users can see the difference of input command tracking and can adjust time setting by using parameter P1-34, P1-35, P1-36 to improve the actual motor performance according to actual condition.

Analog Speed Command Low-pass Filter

Analog Speed Command Low-pass Filter is used to eliminate high frequency response and electrical interference from an analog speed command and it is also with smoothing function.

Relevant parameters:

P1 - 06

SFLT

Accel / Decel Smooth Constant of Analog Speed Command (Low-pass Filter)

Communication Addr.: 0106H

Default: 0

Related Section:

Applicable Control Mode: S

Section 6.3.3

Unit: ms

Range: 0 ~ 1000 (0: Disabled)



- 1) If the setting value of parameter P1-06 is set to 0, it indicates the function of this parameter is disabled and the command is just By-Pass.

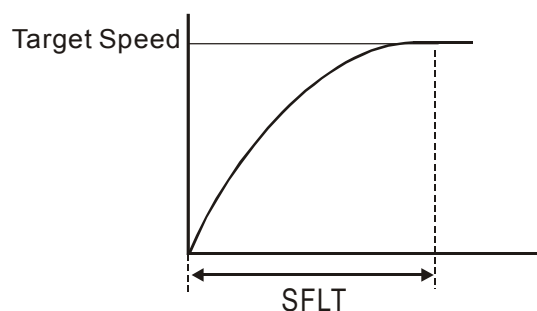

Chapter 6 Control Modes of Operation | ASDA-A&A+ Series

6.3.4 Analog Speed Input Scaling

The analog voltage between **V_REF** and **GND** determines the motor speed command. Using with parameter P1-40 (Max. Analog Speed Command) can adjust the speed control ramp and its range.

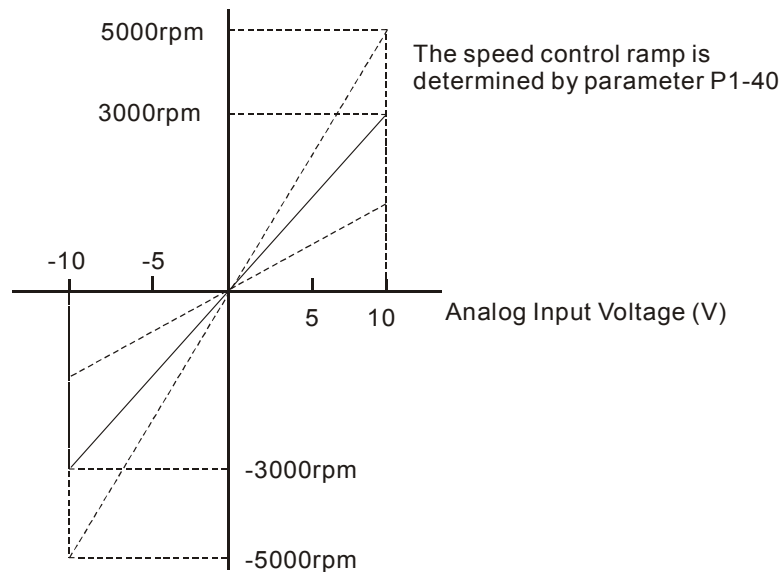

Relevant parameters:

P1 - 40▲	VCM	Max. Analog Speed Command or Limit	Communication Addr.: 0128H
-----------------	------------	---	-----------------------------------

Default: rated speed

Applicable Control Mode: S/T

Unit: r/min

Range: 0 ~ 10000

Settings:

In **Speed mode**, this parameter is used to set the speed at the maximum input voltage (10V) of the analog speed command.

In **Torque mode**, this parameter is used to set the speed at the maximum input voltage (10V) of the analog speed limit.

For example, in speed mode, if P1-40 is set to 3000 and the input voltage is 10V, it indicates that the speed command is 3000 r/min. If P1-40 is set to 3000, but the input voltage is changed to 5V, then the speed command is changed to 1500 r/min.

Speed command / limit = Input voltage x setting/10

Chapter 6 Control Modes of Operation | ASDA-A&A+ Series

ASDA-A+ Series:

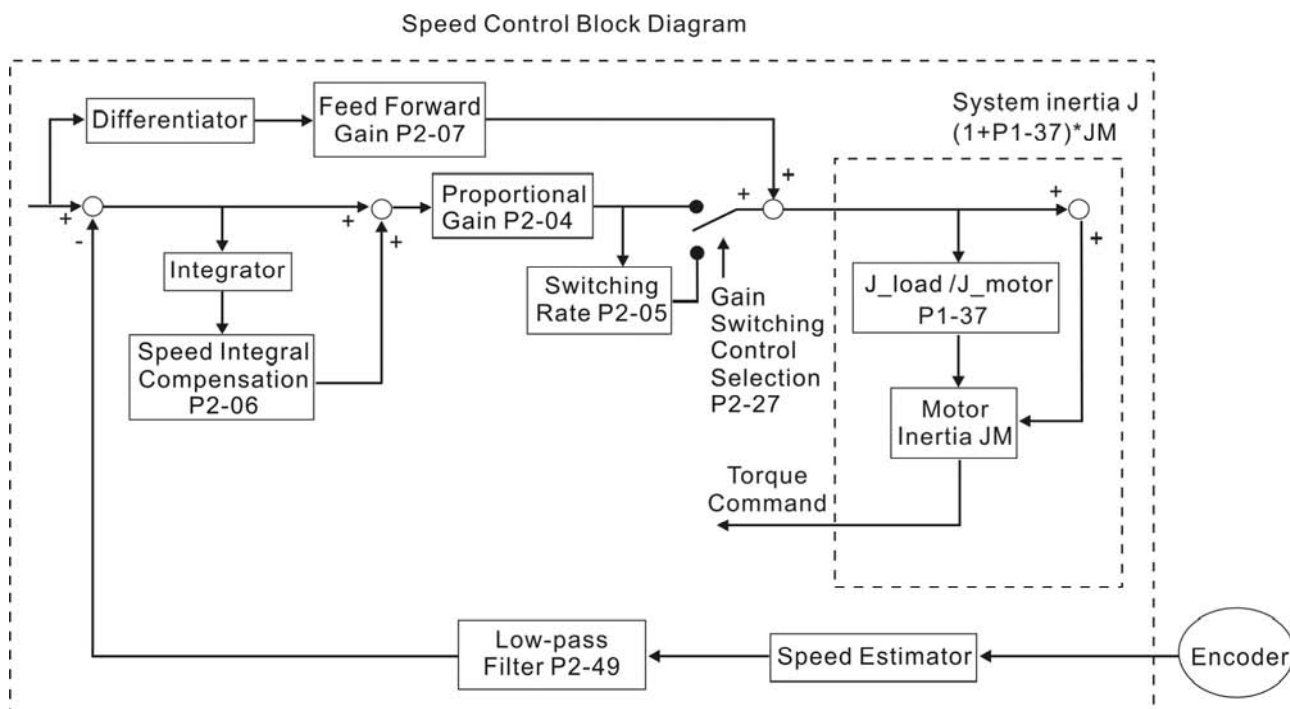

There are two turning modes of gain adjustment: Manual and Auto modes. The gain of ASDA-A and ASDA-A+ series servo drives can be adjusted by using any one of three tuning modes.

- **Manual Mode:** User-defined loop gain adjustment. When using this mode, all auto and auxiliary function will be disabled.
- **Auto Mode:** Continuous adjustment of loop gains according to measured inertia, with ten levels of system bandwidth. The parameter set by user is default value.
- **Easy Mode:** Robust for wide range of external load inertia change, with ten levels of system stiffness. Using easy mode can immediately suppress the interference of external load and mechanical resonance and also stand for the load inertia change.

The mode of gain adjustment can be selected by parameter P2-32:

P2 - 32▲	AUT2	Tuning Mode Selection	Communication Addr.: 0220H
----------	------	-----------------------	----------------------------

Default: 0

Applicable Control Mode: ALL

Unit: N/A

Range: 0 ~ 5

Settings:

0: Manual mode

1: Easy mode (for ASDA-A series only, ASDA-A+ series does not support this mode)

2: AutoMode (PI) [Continuous adjustment]

3: AutoMode (PI) [Fix the ratio of Load Inertia to servo motor inertia and response level can be adjusted]

4: AutoMode (PDFF) [Continuous adjustment]

Related Section:

Section 5.6, Section 6.3.6

Chapter 6 Control Modes of Operation | ASDA-A&A+ Series

5: AutoMode (PDFF) [Fix the ratio of Load Inertia to servo motor inertia and response level can be adjusted]

PI : Proportional - Integral control

PDFF : Pseudo-Derivative Feedback and Feedforward

Explanation of Auto-tuning:

1. When switching mode #2 or #4 to #3 or #5, the system will save the measured load inertia value automatically and memorized in P1-37. Then, set the corresponding parameters according to this measured load inertia value.
2. When switching mode #2 or #4 to #0, it indicates all automatically measured load inertia value will be aborted, and all setting of parameters will be returned to original setting value in #0 manual mode.
3. When switching mode #0 to #3 or #5, enter the appropriate load inertia value in P1-37.
4. When switching mode #3 to #0, the setting value of P2-00, P2-04 and P2-06 will change to the value that measured in #3 auto-tuning mode.
5. When switching mode #5 to #0, the setting value of P2-00, P2-04, P2-06, P2-25 and P2-26 will change to the value that measured in #5 auto-tuning mode

Manual Mode

When Tuning Mode Settings of P2-32 is set to 0, the users can define the proportional speed loop gain (P2-04), speed integral gain (P2-06) feed forward gain (P2-07) and ratio of load inertia to servo motor Inertia (1-37). Please refer to the following description:

- Proportional gain: Adjust this gain can increase the position loop responsiveness.
- Integral gain: Adjust this gain can enhance the low-frequency stiffness of speed loop and eliminate the steady error. Also, reduce the value of phase margin. Over high integral gain will result in the unstable servo system.
- Feed forward gain: Adjust this gain can decrease the phase delay error

Relevant parameters:

P2 - 04	KVP	Proportional Speed Loop Gain	Communication Addr.: 0204H
----------------	------------	-------------------------------------	-----------------------------------

Default: 500

Related Section:

Applicable Control Mode: ALL

Section 6.3.6

Unit: rad/s

Range: 0 ~ 20000 (ASDA-A series)

0 ~ 4095 (ASDA-A+ series)

Settings:

This parameter is used to set the speed loop gain. When the value of proportional speed loop gain is increased, it can expedite speed loop response. However, if the setting value is over high, it may generate vibration or noise.

Chapter 6 Control Modes of Operation | ASDA-A&A+ Series

P2 - 06	KVI	Speed Integral Compensation	Communication Addr.: 0206H
----------------	------------	------------------------------------	-----------------------------------

Default: 100

Applicable Control Mode: ALL

Unit: N/A

Range: 0 ~ 4095 (ASDA-A series)
0 ~ 1023 (ASDA-A+ series)

Settings:

This parameter is used to set the integral time of speed loop. When the value of speed integral compensation is increased, it can improve the speed response ability and decrease the speed control deviation. However, if the setting value is over high, it may generate vibration or noise.

Related Section:

Section 6.3.6

P2 - 07	SFG	Speed Feed Forward Gain	Communication Addr.: 0207H
----------------	------------	--------------------------------	-----------------------------------

Default: 0

Applicable Control Mode: ALL

Unit: 0.0001

Range: 0 ~ 20000

Settings:

This parameter is used to set the feed forward gain when executing speed control command.

When using speed smooth command, increase gain can improve speed track deviation.

When not using speed smooth command, decrease gain can improve the resonance condition of mechanical system.

Related Section:

Section 6.3.6

In theory, stepping response can be used to explain proportional gain (KVP), integral gain (KVI) and feed forward gain (KVF). Now we use frequency area and time area respectively to explain the logic.

Frequency Domain

STEP 1: Set the value of KVI=0, the value of KVF=0 and adjust the value of KVP.

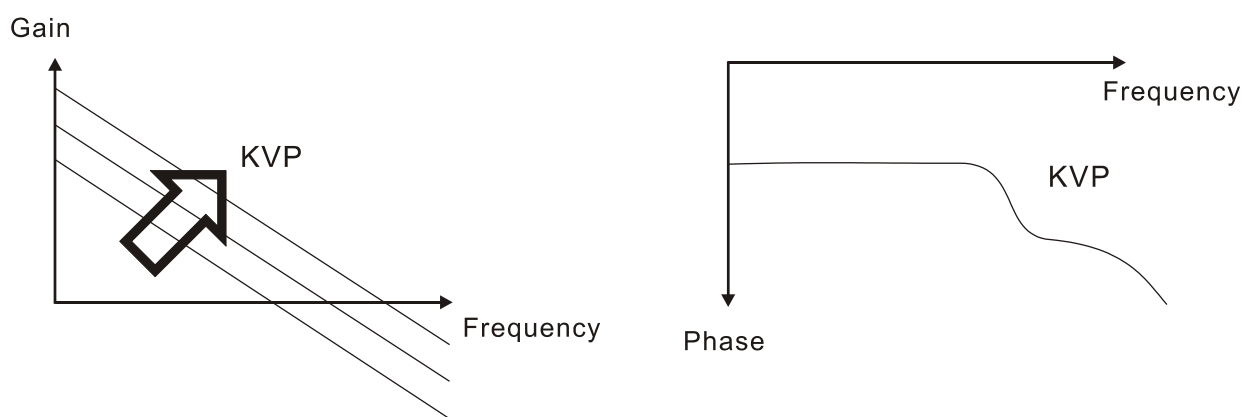

Chapter 6 Control Modes of Operation | ASDA-A&A+ Series

STEP 2 : Fix the value of KVP and adjust the value of KVI.

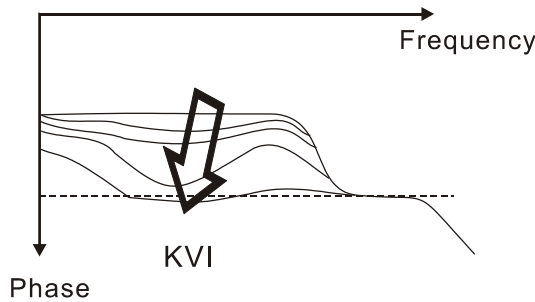
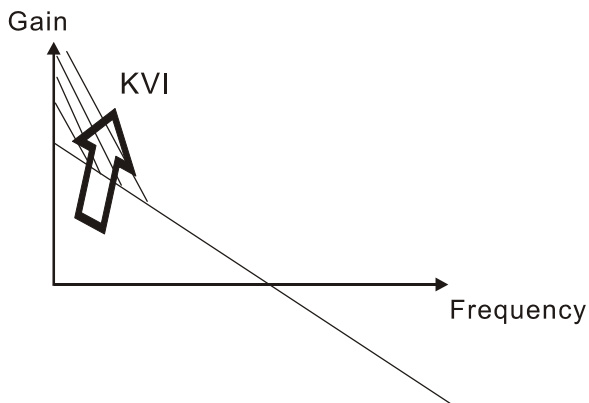

STEP 3 : Select the value of KVI, if the value of phase margin is too small, re-adjust the value of KVP again to obtain the value, 45deg of phase margin.

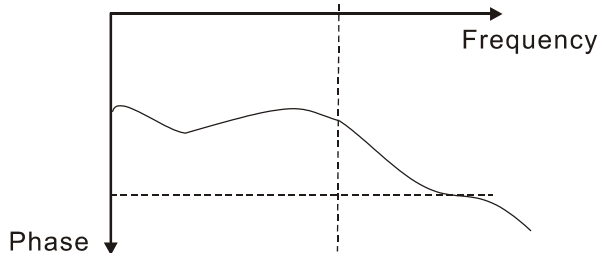
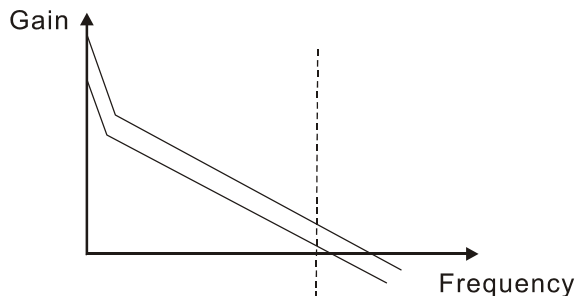

Time Domain

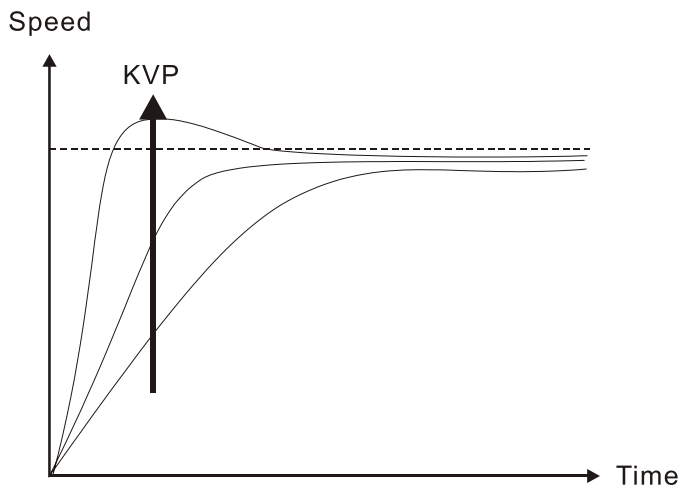

When the value of KVP is greater, the value of the responsiveness is also greater and the raising time is shorter. However, when the value of phase margin is over low, it is not helpful to steady error. But it is helpful to dynamic tracking error.

Chapter 6 Control Modes of Operation | ASDA-A&A+ Series

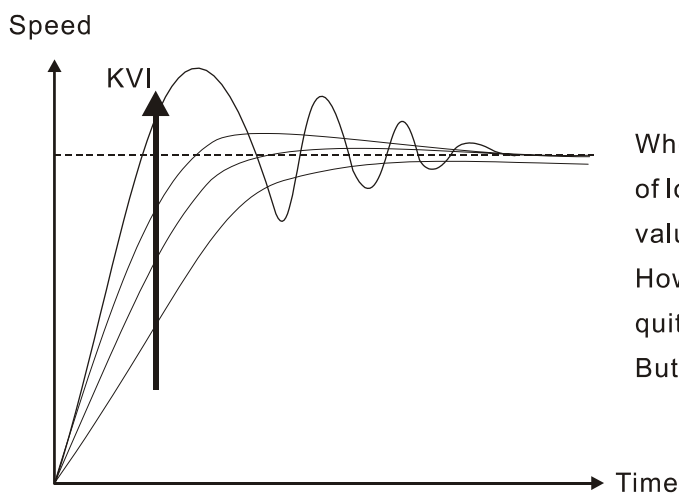

When the value of KVI is greater, the value of low-frequency gain is also greater and the value of steady error is nearly zero (0). However, the value of phase margin will reduce quite substantially. It is helpful to steady error. But it is not helpful to dynamic tracking error.

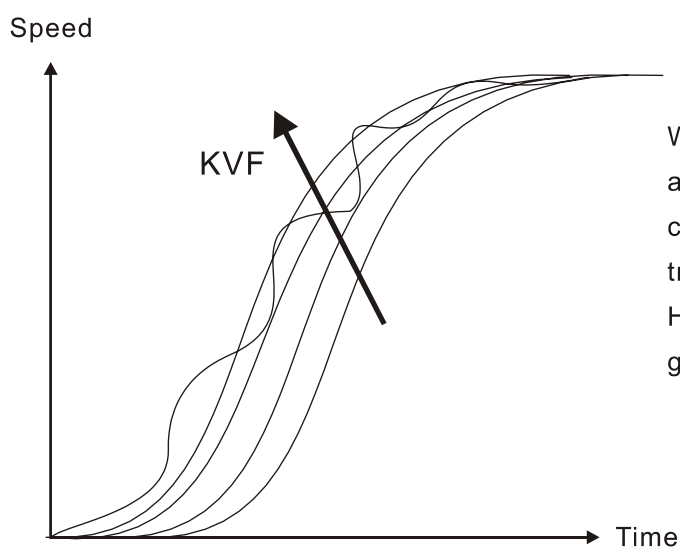

When the value of KVF is nearly to 1 and the forward compensation is more complete, then the value of dynamic tracking error will become very small. However, when the value of KVF is too great, it may cause vibration.

In general, the equipment, such as spectrum analyzer is needed and used to analyze when using frequency domain method and the users also should have this kind of analysis technology. However, when using time domain method, the users only need to prepare an oscilloscope. Therefore, the general users usually use time domain method with the analog DI/DO terminal provided by the servo drive to adjust what is called as PI (Proportional and Integral) type controller. As for the performance of torque shaft load, input command tracking and torque shaft load have the same responsiveness when using frequency domain method and time domain method. The users can reduce the responsiveness of input command tracking by using input command low-pass filter.

Easy Mode (for ASDA-A series only, ASDA-A+ series does not support this mode)

When P2-32 is set to 1, the easy mode function is activated. In order to enhance the performance of servo system, ASDA-A series servo drive provide "Robust Control Technology" when the users select the easy mode of tuning technology. The following introduces the basic structure.

The servo motor with inertia change will operate and be close to ideal reference mode due to the feedback inside of current loop and the torque load will give the compensation immediately inside of the

Chapter 6 Control Modes of Operation | ASDA-A&A+ Series

current loop. When the permissible inertia change is greater, it will be much easier to influence the performance of servo system. For the strong functionality and robust control of Delta servo system, the easy mode provides servo system can be robust for the wide range of external load inertia change, with 16 levels of system stiffness and responsiveness.

Users only need to set parameter P2-31 to select 16 levels of system stiffness and responsiveness. The value is higher, the stiffness is more increased and the responsiveness is higher.

Relevant parameters:

P2 - 31	AUT1	Auto Mode Responsiveness Level	Communication Addr.: 021FH
----------------	-------------	---------------------------------------	-----------------------------------

Default: 44

Related Section:

Applicable Control Mode: ALL

Section 5.6, Section 6.3.6

Unit: N/A

Range: 0 ~ FF (0 ~ FF: 0 indicates the lowest setting and F indicates the highest setting (total 16 settings available))

Settings:

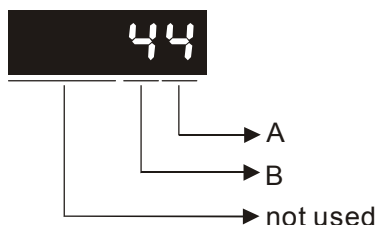

ASDA-A series:

This parameter allows the users to set the stiffness setting of easy mode and the responsiveness level of auto-tuning mode. Users can control the stiffness and responsiveness according to application condition. When the setting value is higher, the stiffness and the responsiveness is higher.

A: Stiffness setting of easy mode

B: Responsiveness level of auto-tuning mode

ASDA-A+ series:

This parameter allows the users to set the responsiveness level setting of auto-tuning mode. Users can control the responsiveness according to application condition. When the setting value is higher, the responsiveness is higher.

A: No function

B: Responsiveness level of auto-tuning mode



- 1) This parameter is activated by P2-32.
- 2) Please refer to Section 5.6 for the tuning procedure and the related settings.

Chapter 6 Control Modes of Operation | ASDA-A&A+ Series

Stiffness Setting in Easy Mode (P2-31 value "A") and the setting of P2-00, P2-25

Level (P2-31 Value A)	Load Range (J_load / J_motor)	Max. Load Corresponding Responsiveness	KPP (P2-00)	NLP (P2-25)	Remark
Low Responsive- ness Level	1	50~100	5Hz	5	The setting value of P2-00 and P2-25 must be inputted manually
	2	30~50	8Hz	8	
	3	20~30	11Hz	11	
	4	16~20	15Hz	15	
Medium Responsiveness Level	5	12~16	20Hz	20	The setting value of P2-00 and P2-25 must be inputted manually
	6	8~12	27Hz	27	
	7	5~8	40Hz	40	
	8	2~5	60Hz	60	
	9	0~2	115Hz	115	
High Responsiveness Level	A	0~2	127Hz	127	The setting value of P2-00 and P2-25 must be inputted manually
	B	2~8	103Hz	103	
	C	8~15	76Hz	76	
	D	15~25	62Hz	62	
	E	25~50	45Hz	45	
	F	50~100	36Hz	36	

Auto Mode (Continuous adjustment)

This Auto Mode provides continuous adjustment of loop gains according to measured inertia automatically. It is suitable when the load inertia is fixed or the load inertia change is small and is not suitable for wide range of load inertia change. The period of adjustment time is different depending on the acceleration and deceleration of servo motor. To change the stiffness and responsiveness, please use parameter P2-31.

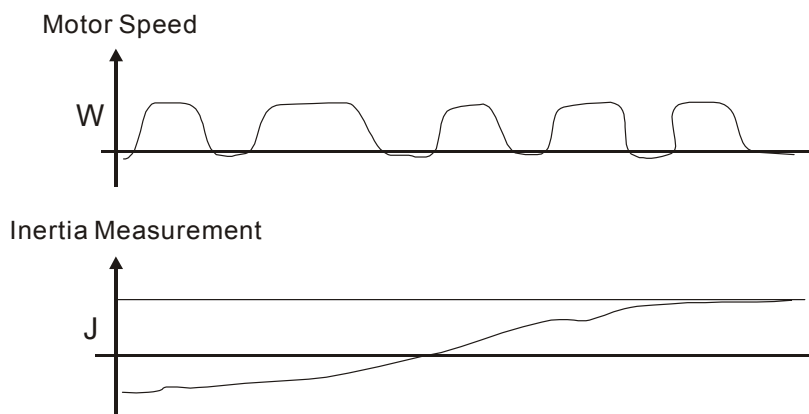

Chapter 6 Control Modes of Operation | ASDA-A&A+ Series

6.3.7 Resonance Suppression

The resonance of mechanical system may occur due to excessive system stiffness or frequency response. However, this kind of resonance condition can be improved, suppressed, even can be eliminated by using low-pass filter (parameter P2-25) and notch filter (parameter P2-23, P2-24) without changing control parameter.

Relevant parameters:

P2 - 23	NCF	Notch Filter (Resonance Suppression)	Communication Addr.: 0217H
----------------	------------	---	-----------------------------------

Default: 1000

Related Section:

Applicable Control Mode: ALL

Section 6.3.7

Unit: Hz

Range: 50 ~ 1000

Settings:

This parameter is used to set resonance frequency of mechanical system. It can be used to suppress the resonance of mechanical system. If P2-24 is set to 0, this parameter is disabled.

P2 - 24	DPH	Notch Filter Attenuation Rate (Resonance Suppression)	Communication Addr.: 0218H
----------------	------------	--	-----------------------------------

Default: 0

Related Section:

Applicable Control Mode: ALL

Section 6.3.7

Unit: dB

Range: 0 ~ 32

Settings: 0: Disabled

P2 - 25	NLP	Low-pass Filter Time Constant (Resonance Suppression)	Communication Addr.: 0219H
----------------	------------	--	-----------------------------------

Default: 2 (1kW and below models) or

Related Section:

5 (above 1kW models)

Section 6.3.7

Applicable Control Mode: ALL

Unit: ms

Range: 0 ~ 1000

Settings: 0: Disabled

This parameter is used to set low-pass filter time constant of resonance suppression.

Chapter 6 Control Modes of Operation | ASDA-A&A+ Series

Speed Control Block Diagram

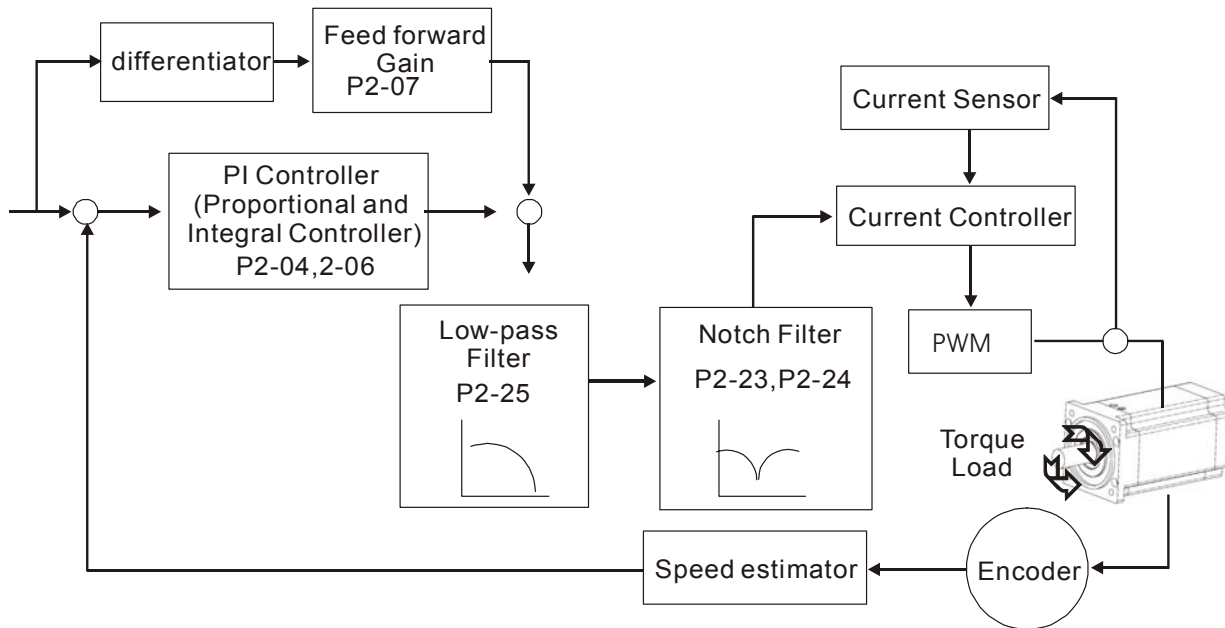

Low-pass filter

Please use parameter P2-25. The figure below shows the resonant open-loop gain.

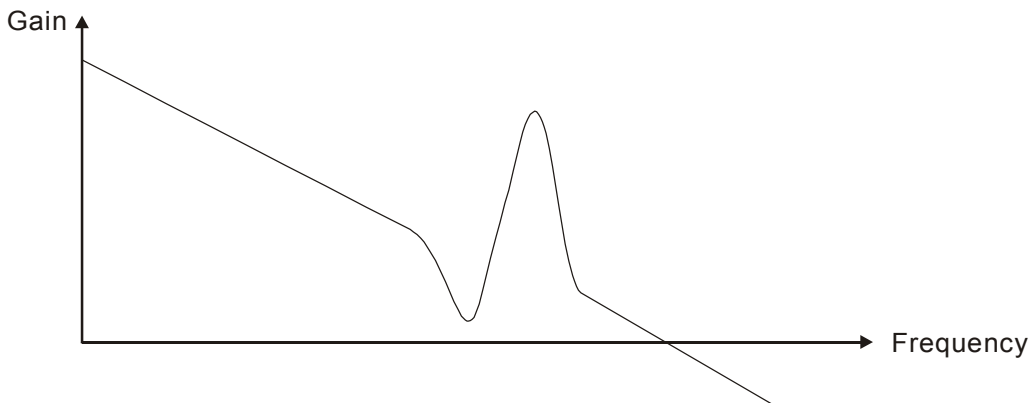

When the low-pass filter (parameter P2-25) is adjusted from 0 to high value, the value of Low-pass frequency (BW) will become smaller (see the figure below). The resonant condition is improved and the frequency response and phase margin will also decrease.

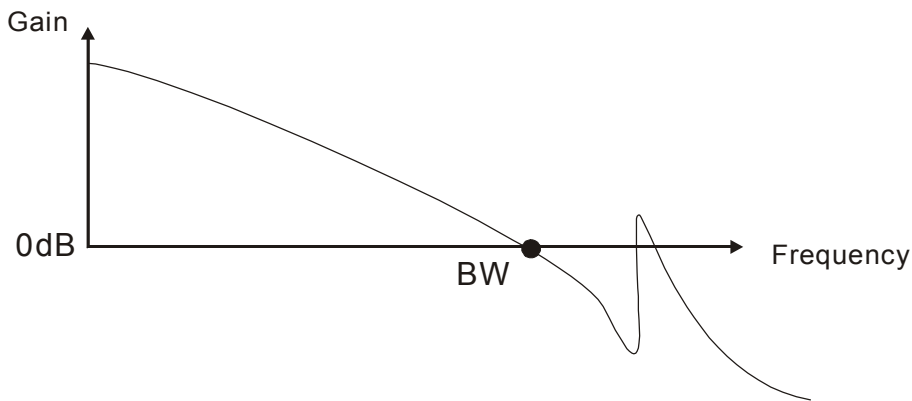

Chapter 6 Control Modes of Operation | ASDA-A&A+ Series

Notch Filter

Usually, if the users know the resonance frequency, we recommend the users can eliminate the resonance conditions directly by using notch filter (parameter P2-23, P2-24). However, the range of frequency setting is from 50 to 1000Hz only and the range of resonant attenuation is 0~32 dB only. Therefore, if the resonant frequency is out of this range, we recommend the users to use low-pass filter (parameter P2-25) to improve resonant condition.

Please refer to the following figures and explanation to know how to use notch filter and low-pass filter to improve resonant condition.

Use Notch Filter to suppress resonance

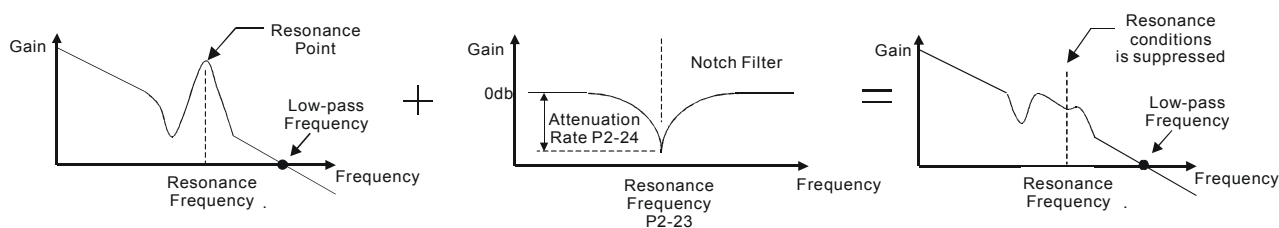

Use Low-pass Filter to suppress resonance

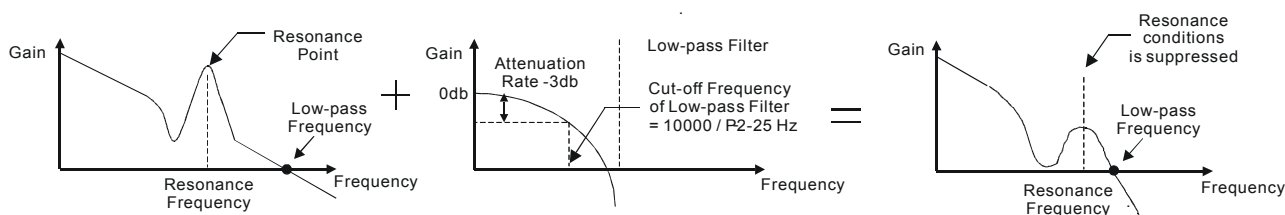

When the low-pass filter (parameter P2-25) is adjusted from 0 to high value, the value of Low-pass frequency will become smaller (see the figure on page 6-26). The resonant condition is improved but the frequency response and phase margin will also decrease and the system may become unstable. Therefore, if the users know the resonance frequency, the users can eliminate the resonance conditions directly by using notch filter (parameter P2-23, P2-24). Usually, if the resonant frequency can be recognized, we recommend the users can directly use notch filter (parameter P2-23, P2-24) to eliminate the resonance. However, if the resonant frequency will drift or drift out of the notch filter range, we recommend the users not to use notch filter and use low-pass filter to improve resonant conditions.

Chapter 6 Control Modes of Operation | ASDA-A&A+ Series

6.4 Torque Control Mode

The torque control mode (T or Tz) is usually used on the applications of torque control, such as printing machine, spinning machine, twister, etc. Delta ASDA-A and ASDA-A+ series servo drives support two kinds of command sources in torque control mode. One is external analog signal and the other is internal parameter. The external analog signal is from external voltage input and it can control the torque of servo motor. The internal parameters are from P1-12 to P1-14 which are used to be the torque command in torque control mode.

6.4.1 Command Source of Torque Control Mode

Torque command Sources:

- 1) External analog signal: External analog voltage input, -10V to +10V
- 2) Internal parameter: P1-12 to P1-14

The command source selection is determined by the DI signal of CN1 connector.

Torque Command	DI signal of CN1		Command Source			Content	Range
	TCM1	TCM0	Mode	T	Tz		
T1	0	0	Mode	T	External analog signal	Voltage between T-REF-GND	+/- 10 V
				Tz	None	Torque command is 0	0
T2	0	1	Internal parameter			P1-12	+/- 300 %
T3	1	0				P1-13	+/- 300 %
T4	1	1				P1-14	+/- 300 %

- State of TCM0~1: 0: indicates OFF (Normally Open); 1: indicates ON (Normally Closed)
- When TCM0 and TCM1 are both 0 (OFF), if the control mode of operation is Tz, then the command is 0. Therefore, if the users do not use analog voltage as torque command, the users can choose Tz mode to operation torque control to avoid the zero point drift problem of analog voltage. If the control mode of operation is T, then the command is the analog voltage between T-REF and GND. The setting range of the input voltage is from -10V to +10V and the corresponding torque is adjustable (see parameter P1-41).
- When at least one of TCM0 and TCM1 is not 0 (OFF), the torque command is internal parameter. The command is valid (enabled) after either TCM0 or TCM1 is changed.

The torque command that is described in this section not only can be taken as torque command in torque control mode (T or Tz mode) but also can be the torque limit input command in position mode (P mode) and speed control mode (S or Sz mode).

Chapter 6 Control Modes of Operation | ASDA-A&A+ Series

6.4.2 Structure of Torque Control Mode

Basic Structure:

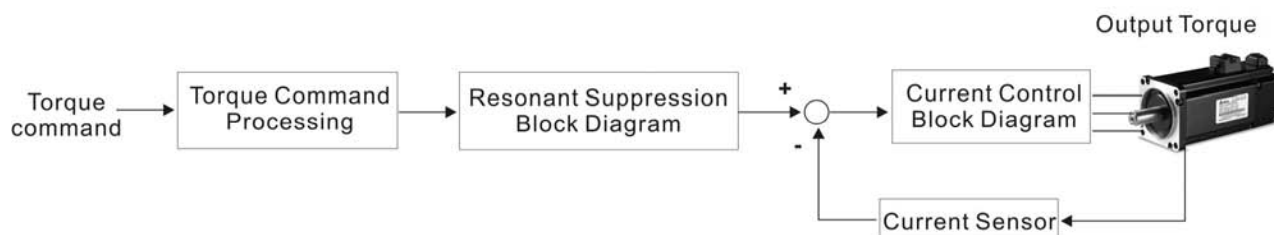

The torque command processing is used to select the command source of torque control according to chapter 6.4.1, including max. analog torque command (parameter P1-41) and smoothing strategy of torque control mode. The current control block diagram is used to manage the gain parameters of the servo drive and calculate the current input provided to motor instantaneously. As the current control block diagram is too complicated, setting the parameters of current control block diagram is not allowed. The function and structure of torque command processing is shown as the figure below:

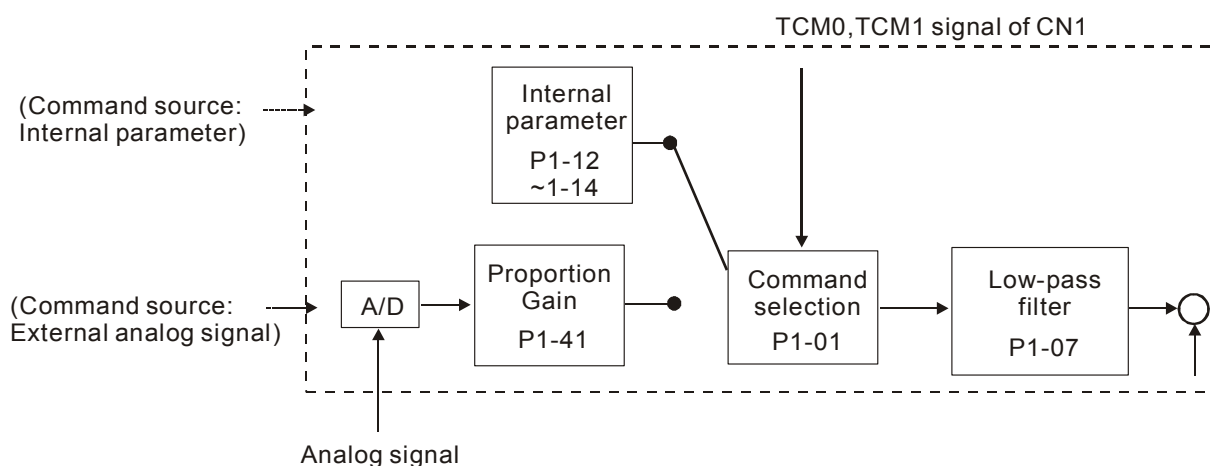

The command source is selected according to the state of TCM0, TCM1 and parameter P1-01 (T or Tz). Whenever the command signal needs to be more smoothly, we recommend the users to use proportional gain (scalar) and low-pass filter to adjust torque.

6.4.3 Smoothing Strategy of Torque Control Mode

Relevant parameters:

P1 - 07	TFLT	Smooth Constant of Analog Torque Command (Low-pass Filter)	Communication Addr.: 0107H
----------------	-------------	---	-----------------------------------

Default: 0

Applicable Control Mode: T

Unit: ms

Range: 0 ~ 1000 (0: Disabled)

Related Section:

Section 6.4.3

Chapter 6 Control Modes of Operation | ASDA-A&A+ Series

NOTE

- 1) If the setting value of parameter P1-07 is set to 0, it indicates the function of this parameter is disabled and the command is just By-Pass.

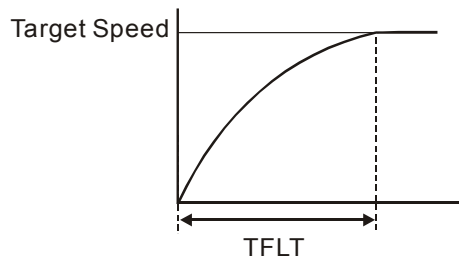

6.4.4 Analog Torque Input Scaling

The analog voltage between T_REF and GND controls the motor torque command. Using with parameter P1-41 can adjust the torque control ramp and its range.

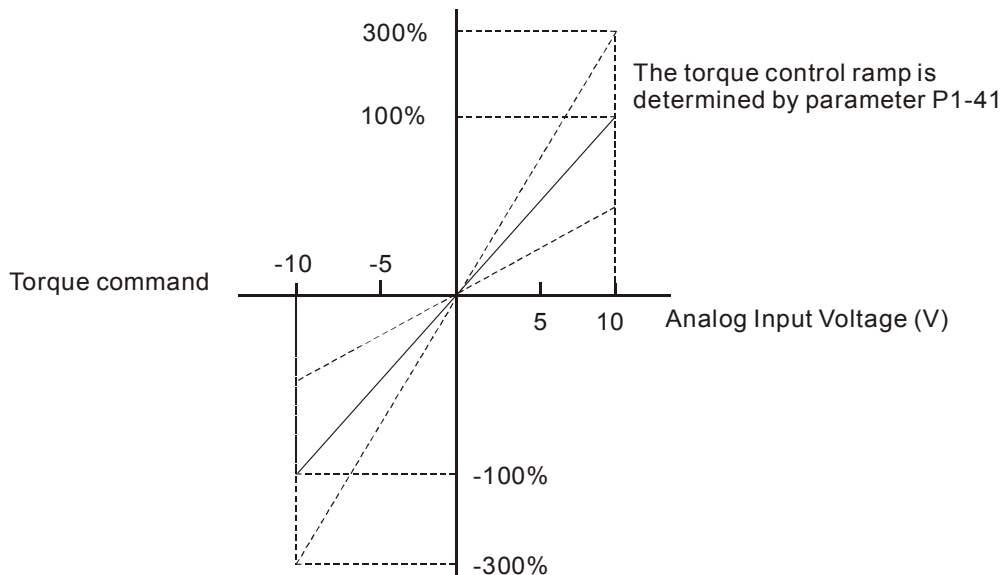

Relevant parameters:

P1 - 41 ▲	TCM	Max. Analog Torque Command or Limit	Communication Addr.: 0129H
-----------	-----	-------------------------------------	----------------------------

Default: 100

Applicable Control Mode: ALL

Unit: %

Range: 0 ~ 1000

Settings:

In **Torque mode**, this parameter is used to set the output torque at maximum input voltage (10V) of analog torque command.

In **Position** and **Speed mode**, this parameter is used to set output torque at maximum input voltage (10V) of analog torque limit

Chapter 6 Control Modes of Operation | ASDA-A&A+ Series

For example, in torque mode, if P1-41 is set to 100 and the input voltage is 10V, it indicates that the torque command is 100% rated torque. If P1-41 is set to 100, but the input voltage is changed to 5V, then the torque command is changed to 50% rated torque.

$$\text{Torque command / limit} = \text{Input voltage} \times \text{setting} / 10 (\%)$$

6.4.5 Timing Chart of Torque Control Mode

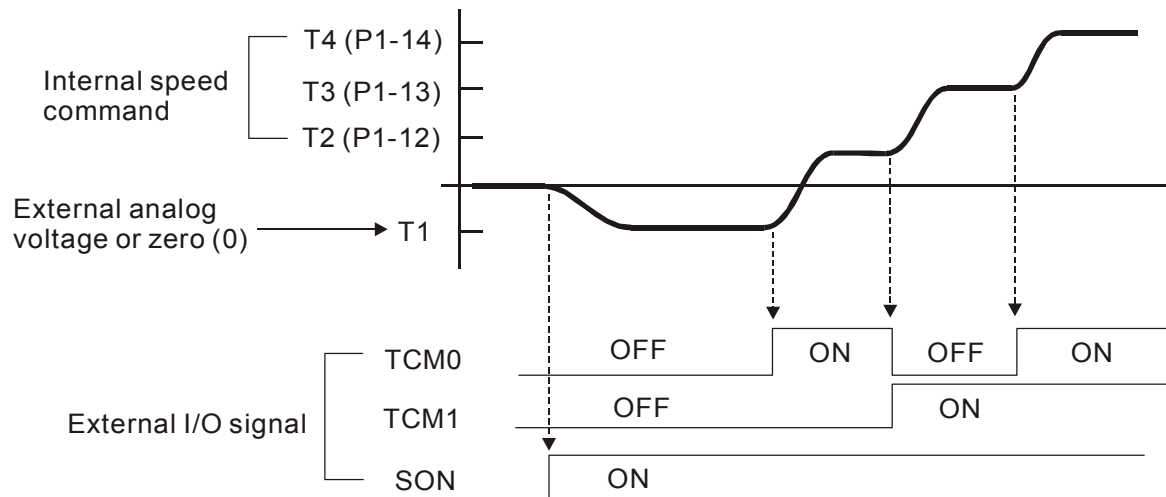

NOTE

- 1) OFF indicates normally open and ON indicates normally closed.
- 2) When torque control mode is Tz, the torque command T1=0; when torque control mode is T, the speed command T1 is external analog voltage input (Please refer to P1-01).
- 3) After Servo ON, the users can select command according to the state of TCM0~1.

Chapter 6 Control Modes of Operation | ASDA-A&A+ Series

6.5 Control Modes Selection

Except signal control mode operation, ASDA-A and ASDA-A+ series servo drives also provide Pt-S, Pr-S, S-T, Pt-T, Pr-T these five multiple modes for the users to select.

- 1) Speed / Position mode selection: Pt-S, Pr-S
- 2) Speed / Torque mode selection: S-T
- 3) Torque / Position mode selection: Pt-T, Pr-T

Mode	Name	Code	Description
Dual Mode	Pt-S	06	Either Pt or S control mode can be selected via the Digital Inputs (DI)
	Pt-T	07	Either Pt or T control mode can be selected via the Digital Inputs (DI)
	Pr-S	08	Either Pr or S control mode can be selected via the Digital Inputs (DI)
	Pr-T	09	Either Pr or T control mode can be selected via the Digital Inputs (DI)
	S-T	10	Either S or T control mode can be selected via the Digital Inputs (DI)

Sz and Tz mode selection is not provided. In order to avoid using too much DI inputs, we recommend that the users can use external analog signal as input command in speed and torque mode to reduce the use of DI inputs (SPD0~1 or TCM0~1). In position mode, we recommend that the users can use Pt mode to input pulse to reduce the use of DI inputs (POS0~2).

Please refer to table 3.B and table 3.C in section 3.3.2 to see the default pin number of DI/DO signal.

6.5.1 Speed / Position Control Mode Selection

Pt-S Mode / Pr-S Mode:

The command source of Pt-S mode is from external input pulse. The command source of Pr-S mode is from internal parameters (P1-15 to P1-30). The speed command can be the external analog voltage or internal parameters (P1-09 to P1-11). The speed and position mode switching is controlled by the S-P signal. The selection will be more complicated when the position of Pr-S mode and speed command are both selected through DI signal.

The timing chart of speed / position control mode selection is shown as the figure below:

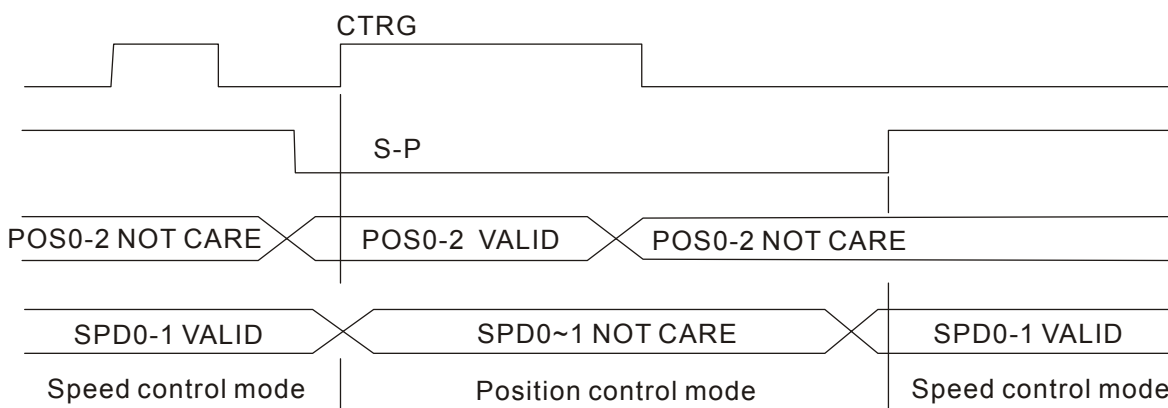

Figure 1. : Speed / Position Control Mode Selection

Chapter 6 Control Modes of Operation | ASDA-A&A+ Series

In speed mode (when S-P is ON), speed command is selected by SPD0~1 and CTRG is disabled at this time. When switching to the position mode (when S-P is OFF), the position command is not determined (it needs to wait that CTRG is on the rising edge), so the motor stop running. Once CTRG is on the rising edge, position command will be selected according to POS0~2 and the motor will immediately move to the determined position. After S-P is ON, it will immediately return to speed mode.

For the relationship between DI signal and selected command in each mode, please refer to the introduction of single mode.

6.5.2 Speed / Torque Control Mode Selection

S-T Mode:

The speed command can be the external analog voltage or internal parameters (P1-09 to P1-11) and SPD0~1 is used to select speed command. The same as speed command, the torque command can be the external analog voltage or internal parameters (P1-12 to P1-14) and TCM0~1 is used to select torque command. The speed and torque mode switching is controlled by the S-T signal.

The timing chart of speed / torque control mode selection is shown as the figure below:

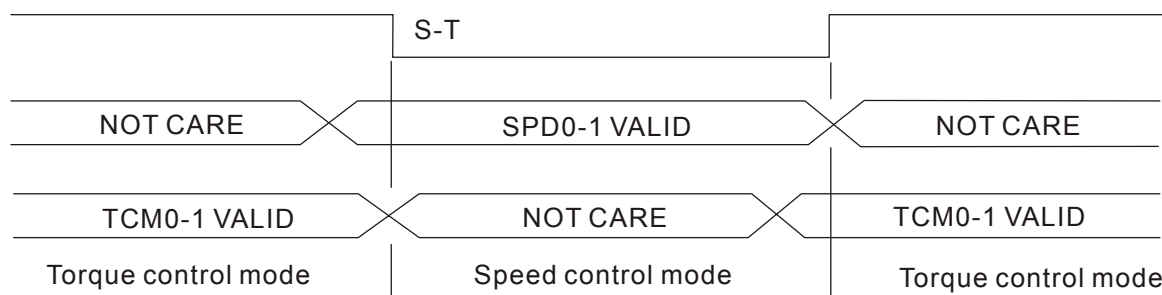

Figure 2. : Speed / Torque Control Mode Selection

In torque mode (when S-T is ON), torque command is selected by TCM0~1. When switching to the speed mode (when S-T is OFF), the speed command is selected by SPD0~1, and then the motor will immediately rotate following the command. After S-T is ON again, it will immediately return to torque mode.

6.5.3 Torque / Position Control Mode Selection

Pt-T Mode / Pr-T Mode:

The command source of Pt-T mode is from external input pulse. The command source of Pr-T mode is from internal parameters (P1-15 to P1-30). The torque command can be the external input pulse or internal parameters (P1-12 to P1-14). The torque and position mode switching is controlled by T-P signal. The selection will be more complicated when the position of Pr-T mode and torque command are both selected through DI signal.

Chapter 6 Control Modes of Operation | ASDA-A&A+ Series

The timing chart of speed / position control mode selection is shown as the figure below:

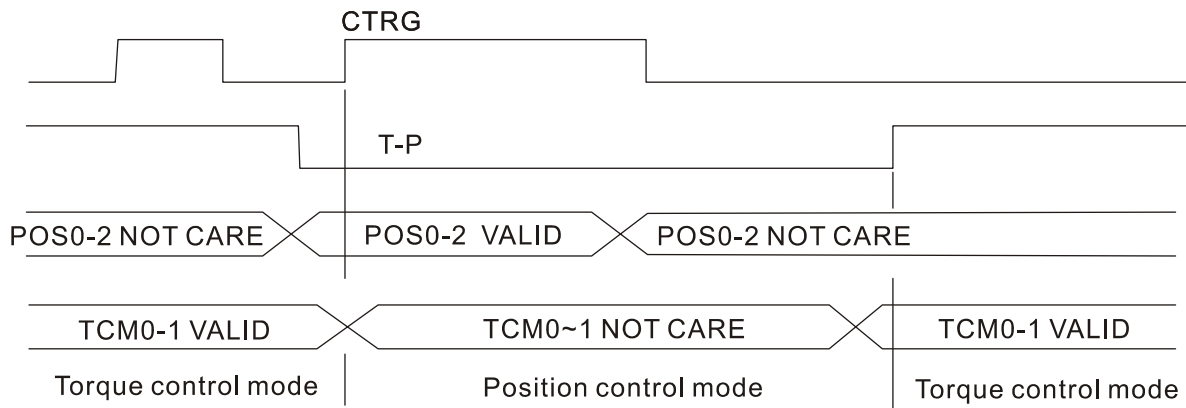

Figure 3. : Torque / Position Control Mode Selection

In position mode (when T-P is ON), the motor will start to count pulse and operate following the external pulse command. When switching to the torque mode (when T-P is OFF), it will stop counting pulse even if the pulse command is continuously sent out. The torque command is determined by TCM0~1 and the motor will rotate following the command. After T-P is ON again, it will immediately return to position mode.

For the relationship between DI signal and selected command in each mode, please refer to the introduction of single mode.

Chapter 6 Control Modes of Operation | ASDA-A&A+ Series

6.6 Others

6.6.1 Speed Limit

The max. servo motor speed can be limited by using parameter P1-55 no matter in position, speed or torque control mode.

The command source of speed limit command is the same as speed command. It can be the external analog voltage but also can be internal parameters (P1-09 to P1-11). For more information of speed command source, please refer to chapter 6.3.1.

The speed limit only can be used in torque mode (T mode) to limit the servo motor speed. When the torque command is the external analog voltage, there should be surplus DI signal that can be treated as SPD0~1 and be used to select speed limit command (internal parameter). If there is not enough DI signal, the external voltage input can be used as speed limit command. When the Disable / Enable Speed Limit Function Settings in parameter P1-02 is set to 1, the speed limit function is activated.

The timing chart of speed limit is shown as the figure below:

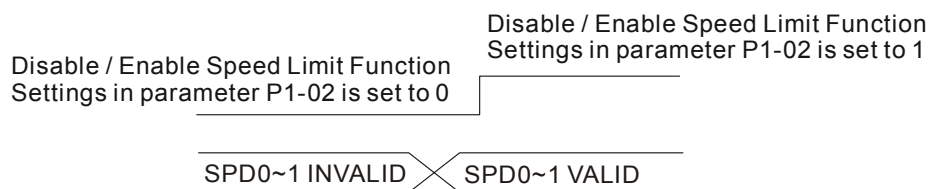

Command Source Selection of Speed Limit

6.6.2 Torque Limit

The command source of torque limit command is the same as torque command. It can be the external analog voltage but also can be internal parameters (P1-12 to P1-14). For more information of torque command source, please refer to chapter 6.4.1.

The torque limit only can be used in position mode (Pt and Pr mode) and speed mode (S mode) to limit the output torque of servo motor. When the position command is the external pulse and speed command is the external analog voltage, there should be surplus DI signal that can be treated as TCM0~1 used to select torque limit command (internal parameter). If there is not enough DI signal, the external voltage input can be used as torque limit command. When the Disable / Enable Torque Limit Function Settings in parameter P1-02 is set to 1, the torque limit function is activated.

The timing chart of torque limit is shown as the figure below:

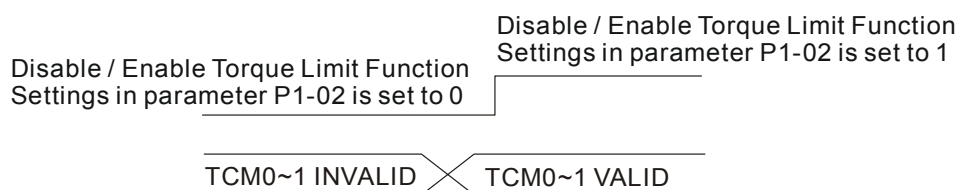

Command Source Selection of Torque Limit

Chapter 6 Control Modes of Operation | ASDA-A&A+ Series

6.6.3 Regenerative Resistor

■ Built-in Regenerative Resistor

When the output torque of servo motor in reverse direction of motor rotation speed, it indicates that there is a regenerative power returned from the load to the servo drive. This power will be transmitted into the capacitance of DC Bus and result in rising voltage. When the voltage has risen to some high voltage, the servo system need to dissipate the extra energy by using a regenerative resistor. ASDA-A and ASDA-A+ series servo drives provide a built-in regenerative resistor and the users also can connect to external regenerative resistor if more regenerative capacity is needed.

The following table shows the specifications of the servo drive's built-in regenerative resistor and the amount of regenerative power (average value) that it can process.

Built-in Regenerative Resistor Specifications				
Servo Drive (kW)	Resistance (Ohm) (parameter P1-52)	Capacity (Watt) (parameter P1-53)	Regenerative Power processed by built-in regenerative resistor (Watt) *1	Min. Allowable Resistance (Ohm)
0.1	40	60	30	40
0.2	40	60	30	40
0.4	40	60	30	20
0.75	40	60	30	20
1.0	40	60	30	20
1.5	40	60	30	20
2.0	20	120	60	10
3.0	20	120	60	10
4.5	20	100	60	10

When the regenerative power exceeds the processing capacity of the servo drive, install an external regenerative resistor. Please pay close attention on the following notes when using a regenerative resistor.

1. Make sure that the settings of resistance (parameter P1-52) and capacity (parameter P1-53) is set correctly.
2. When the users want to install an external regenerative resistor, ensure that its resistance value is the same as the resistance of built-in regenerative resistor. If combining multiple small-capacity regenerative resistors in parallel to increase the regenerative resistor capacity, make sure that the resistance value of the regenerative resistor should comply with the specifications listed in the above table.
3. In general, when the amount of regenerative power (average value) that can be processed is used at or below the rated load ratio, the resistance temperature will increase to 120°C or higher (on condition that when the regeneration continuously occurred). For safety reasons, forced air cooling is good way that can be used to reduce the temperature of the regenerative resistors. We also recommend the users to use the regenerative resistors with thermal switches. As for the load characteristics of the regenerative resistors, please check with the manufacturer.

Chapter 6 Control Modes of Operation | ASDA-A&A+ Series

■ External Regenerative Resistor

When using external regenerative resistor, connect it to P and C, and make sure the circuit between P and D is open. We recommend the users should use the external regenerative resistor that the resistance value following the above table (Built-in Regenerative Resistor Specifications). We ignore the dissipative power of IGBT (Insulated Gate Bipolar Transistor) in order to let the users easily calculate the capacity of regenerative resistor. In the following sections, we will describe Regenerative Power Calculation Method and Simple Calculation Method for calculating the regenerative power capacity of external regenerative resistors.

■ Regenerative Power Calculation Method

(1) Without Load

When there is no external load torque, if the servo motor repeats operation, the returned regenerative power generated when braking will be transmitted into the capacitance of DC bus. After the capacitance voltage exceeds some high value, regenerative resistor can dissipate the remained regenerative power. Use the table and procedure described below to calculate the regenerative power.

ASDA-A Series

Servo Drive (kW)	Rotor Inertia J (kg. m ²)	Regenerative power from empty load 3000r/min to stop Eo (joule)	Max. regenerative power of capacitance Ec (joule)	
Low Inertia	0.1	0.03E-4	0.15	3
	0.2	0.18E-4	0.89	4
	0.4	0.34E-4	1.68	8
	0.75	1.08E-4	5.34	14
	1.0	2.60E-4	12.86	18
	1.5	3.60E-4	17.80	18
	2.0	4.70E-4	23.24	21
Medium Inertia	3.0	11.6E-4	57.36	28
	1.0	5.98E-4	29.57	18
	1.5	8.79E-4	43.47	18
	2.0	15.8E-4	78.13	21
	3.0	43.3E-4	214.1	28

ASDA-A+ Series

Servo Drive (kW)	Rotor Inertia J (kg. m ²)	Regenerative power from empty load 3000r/min to stop Eo (joule)	Max. regenerative power of capacitance Ec (joule)	
4.5	3	54.95	271.73	25
	3.5	54.80	270.98	25
	4.5	77.75	384.47	25

$$E_o = J \times \omega^2 / 182 \text{ (joule)} \quad , \quad \omega : \text{r/min}$$

Chapter 6 Control Modes of Operation | ASDA-A&A+ Series

If the load inertia is $N \times$ motor inertia, the regenerative power will be $(N+1) \times E_0$ when servo motor brakes from 3000r/min to 0. Then, the regenerative resistor can dissipate: $(N+1) \times E_0 - E_c$ (joule). If the time of repeat operation cycle is T sec, then the regenerative power = $2 \times ((N+1) \times E_0 - E_c) / T$. The calculating procedure is as follows:

Step	Procedure	Equation and Setting Method
1	Set the capacity of regenerative resistor to the maximum	Change the value of P1-53 to maximum
2	Set the operation cycle T	Input by the users
3	Set motor speed w_r	Input by the users or read via P0-02 Drive State Display
4	Set load/motor inertia ratio N	Input by the users or read via P0-02 Drive State Display
5	Calculate the max. regenerative power E_0	$E_0 = J \times w_r^2 / 182$
6	Set the regenerative power E_c that can be absorbed	Refer to the table above
7	Calculate the required regenerative power capacity	$2 \times (N+1) \times E_0 - E_c / T$

For example:

If we use 400W servo drive, the time of repeat operation cycle is $T = 0.4$ sec, max. motor speed is 3000r/min, the load inertia = $7 \times$ motor inertia, then the necessary the power of regenerative resistor = $2 \times ((7+1) \times 1.68 - 8) / 0.4 = 27.2W$. If the calculation result is smaller than regenerative power, we recommend the users to use the built-in 60W regenerative resistor. Usually the built-in regenerative resistor provided by ASDA-A and ASDA-A+ series servo drives can meet the requirement of general application when the external load inertia is not excessive.

The users can see when the capacity of regenerative resistor is too small, the accumulated power will be larger and the temperature will also increase. The fault, ALE05 may occur if the temperature is over high. The following figure shows the actual operation of regenerative resistor.

(2) With Load

When there is an external load torque, servo motor is in reverse rotation when external load greater than motor torque. Servo motor is usually in forward rotation and the motor torque output direction is the same as the rotation direction. However, there is still some special condition. If the motor output torque is in the reverse direction of rotation, the servo motor is also in the reverse direction of rotation. The external power is input into the servo drive through servo motor. The Figure 6.21 below is an example. The users can see the motor is in forward rotation at constant speed when a sudden external load torque change and great power is transmitted to regenerative resistor rapidly.

Chapter 6 Control Modes of Operation | ASDA-A&A+ Series

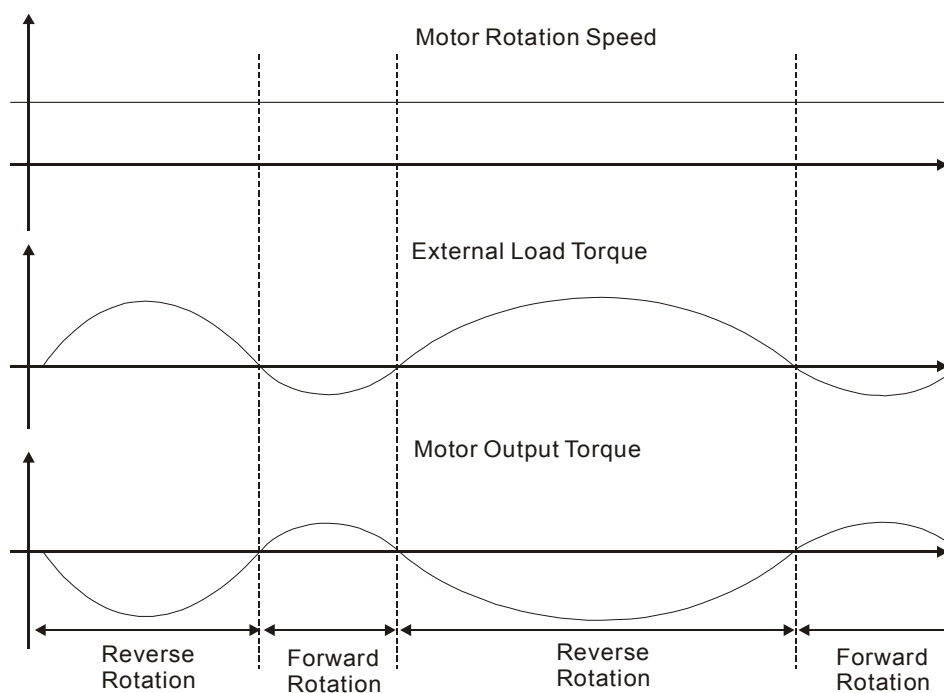

External load torque in reverse direction: $T_L \times W_r$ T_L : External load torque

For the safety, we strongly recommend the users should select the proper resistance value according to the load.

For example:

When external load torque is a +70% rated torque and rotation speed reaches 3000r/min, if using 400W servo drive (rated torque: 1.27Nt-m), then the users need to connect a external regenerative resistor which power is $2 \times (0.7 \times 1.27) \times (3000 \times 2 \times \pi / 60) = 560W$, 40Ω.

■ Simple Calculation Method

The users can select the adequate regenerative resistors according to the allowable frequency required by actual operation and the allowable frequency when the servo motor runs without load. The allowable frequency when the servo motor run without load is the maximum frequency that can be operated during continuous operation when servo motor accelerate from 0r/min to rated speed and decelerate from rated speed down to 0r/min. The allowable frequencies when the servo motor run without load are summarized in the following table.

ASDA-A Series

Allowable frequency when the servo motor runs without load (times/min) and uses built-in regenerative resistor								
Motor Capacity	100W	200W	400W	750W	1.0kW	1.5kW	2.0kW	3.0kW
Servo Motor	01	02	04	07	10	15	20	30
ASMT□□L	12133	2022	1071	337	140	100	155	63
ASMT□□M	-	-	-	-	136	93	104	38

Chapter 6 Control Modes of Operation | ASDA-A&A+ Series

ASDA-A+ Series

Allowable frequency when the servo motor run without load (times/min) and uses built-in regenerative resistor			
Motor Capacity	3.0kW	3.5KW	4.5kW
Servo Motor	30	35	45
ECMA Series	11	11	8

When the servo motor runs with load, the allowable frequency will change according to the changes of the load inertia and rotation speed. Use the following equation to calculate the allowable frequency.

$$\text{Allowable frequency} = \frac{\text{Allowable frequency when servo motor run without load}}{m + 1} \times \left(\frac{\text{Rated speed}}{\text{Operating speed}} \right)^2 \frac{\text{times}}{\text{min.}}$$

m = load/motor inertia ratio

The users can select the adequate external regenerative resistors according to the allowable frequency by referring to the table below:

ASDA-A Series

Allowable frequency when the servo motor run without load (times/min) and uses external regenerative resistor								
Motor Capacity	ASMT□□L							
	100W	200W	400W	750W	1.0kW	1.5kW	2.0kW	3.0kW
Recommended Regenerative Resistor Specifications	01	02	04	07	10	15	20	30
400W 40Ω	-	-	7137	2247	933	674	-	-
1kW 20Ω	-	-	-	-	2333	1685	1291	523

Allowable frequency when the servo motor run without load (times/min) and uses external regenerative resistor				
Motor Capacity	ASMT□□M			
	1.0kW	1.5kW	2.0kW	3.0kW
Recommended Regenerative Resistor Specifications	10	15	20	30
400W 40Ω	913	621	-	-
1kW 20Ω	2282	1552	863	315

ASDA-A+ Series

Allowable frequency when the servo motor run without load (times/min) and uses external regenerative resistor			
Motor Capacity	ECMA Series		
	3.0kW	3.5KW	4.5kW
Recommended Regenerative Resistor Specifications	30	35	45
3kW 10Ω	331	331	234

Chapter 6 Control Modes of Operation | ASDA-A&A+ Series

When the regenerative resistor capacity is not enough, the users can connect to multiple the same capacity regenerative resistors in parallel to increase it.



- 1) Regarding the selection of regenerative resistor, please refer to the table of regenerative resistor specifications described in Appendix A.

6.6.4 Analog Monitor

Users can use analog monitor to observe the required analog voltage signals. ASDA-A and ASDA-A+ series servo drives provide two analog channels, they are PIN No. 15 and 16 of CN1 connector. The parameters relative to analog monitor are shown below.

Relevant parameters:

P0 - 03	MON	Analog Monitor Output	Communication Addr.: 0003H
----------------	------------	------------------------------	-----------------------------------

Default: 01

Related Section:

Applicable Control Mode: ALL

Section 4.3.5

Unit: N/A

Range: 00 ~ 55

Settings:

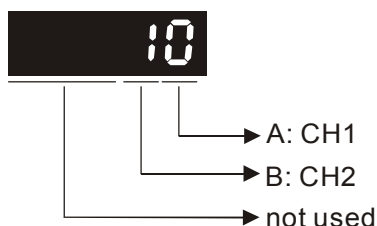

AB: (A: CH1; B: CH2)

0: Motor speed (+/-8V / maximum motor speed)

1: Motor torque (+/-8V / maximum torque)

2: Pulse command frequency (+8Volts / 650Kpps) (ASDA-A series)

Pulse command frequency (+8Volts / 4.5Mpps) (ASDA-A+ series)

3: Speed command (+/-8Volts / maximum speed command)

4: Torque command (+/-8Volts / maximum torque command)

5: V_BUS voltage (+/-8Volts / 450V)

Note: For the setting of analog output voltage proportion, refer to the P1-04 and P1-05.

Example:

P0-03 = 01(CH1 is speed analog output)

Motor speed = (Max. motor speed × V1/8) × P1-04/100, when the output voltage value of CH1 is V1.

Chapter 6 Control Modes of Operation | ASDA-A&A+ Series

P1 - 03	AOUT	Pulse Output Polarity Setting	Communication Addr.: 0103H
----------------	-------------	--------------------------------------	-----------------------------------

Default: 0

Related Section:

Applicable Control Mode: ALL

Section 3.3.3

Unit: N/A

Range: 0 ~ 1

Settings:

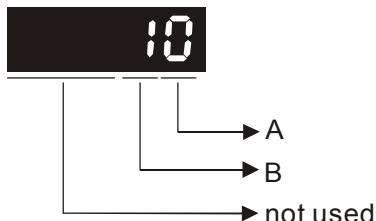

A: Monitor analog output polarity

B: Position pulse output polarity

A=0: MON1(+), MON2(+)

B=0: Forward output

A=1: MON1(+), MON2(-)

B=1: Reverse output

A=2: MON1(-), MON2(+)

A=3: MON1(-), MON2(-)

P1 - 04	MON1	Analog Monitor Output Proportion 1 (CH1)	Communication Addr.: 0104H
----------------	-------------	---	-----------------------------------

Default: 100

Related Section:

Applicable Control Mode: ALL

Section 6.4.4

Unit: % (full scale)

Range: 0 ~ 100

P1 - 05	MON2	Analog Monitor Output Proportion 2 (CH2)	Communication Addr.: 0105H
----------------	-------------	---	-----------------------------------

Default: 100

Related Section:

Applicable Control Mode: ALL

Section 6.4.4

Unit: % (full scale)

Range: 0 ~ 100

P4 - 20	DOF1	Analog Monitor Output Drift Adjustment (CH1)	Communication Addr.: 0414H
----------------	-------------	---	-----------------------------------

Default: Factory setting

Related Section:

Applicable Control Mode: ALL

Section 6.4.4

Unit: mV

Range: -800~800

Settings:

When P2-08 is set to 10, users cannot reset this parameter.

Chapter 6 Control Modes of Operation | ASDA-A&A+ Series**P4 - 21****DOF2****Analog Monitor Output Drift Adjustment (CH2)****Communication Addr.: 0415H**

Default: Factory setting

Related Section: N/A

Applicable Control Mode: ALL

Section 6.4.4

Unit: mV

Range: -800~800

Settings:

When P2-08 is set to 10, users cannot reset this parameter.

For example, when the users want to observe the analog voltage signal of channel 1, if the monitor output setting range is 8V per 325Kpps, then it is needed to change the setting value of parameter P1-04 (Analog Monitor Output Proportion 1) to 50 (=325Kpps/Max. input frequency). Other related parameters setting include parameter P0-03 (A=3) and P1-03 (A=0~3, output polarity setting). In general, when output voltage value of Ch1 is V1, the pulse command frequency is equal to $(\text{Max. input frequency} \times V1/8) \times P1-04/100$.

Because there is an offset value of analog monitor output voltage, the zero voltage level of analog monitor output does not match to the zero point of setting value. We recommend the users can use Analog Monitor Output Drift Adjustment, DOF1 (parameter P4-20) and DOF2 (parameter P4-21) to improve this condition. The maximum output voltage range of analog monitor output is $\pm 8V$. If the output voltage exceed its limit, it is still limited within the range of $\pm 8V$. The resolution provided by ASDA-A and ASDA-A+ series servo drives is 10bit, approximated to 13mv/LSB.

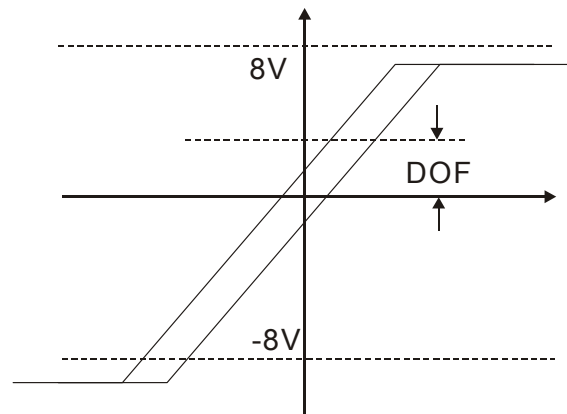

Chapter 6 Control Modes of Operation | ASDA-A&A+ Series

6.6.5 Electromagnetic Brake

When the servo drive is operating, if the digital output BRKR is set to Off, it indicates the electromagnetic brake is disabled and motor is stop running and locked. If the digital output BRKR is set to ON, it indicates electromagnetic brake is enabled and motor can run freely.

There are two parameters that affect the electromagnetic brake. One is parameter P1-42 (MBT1) and the other is parameter P1-43 (MBT2). The users can use these two parameters to set the On and Off delay time of electromagnetic brake. The electromagnetic brake is usually used in perpendicular axis (Z-axis) direction to reduce the large energy generated from servo motor. Using electromagnetic brake can avoid the load may slip since there is no motor holding torque when power is off. Without using electromagnetic brake may reduce the life of servo motor. To avoid malfunction, the electromagnetic brake should be activated after servo system is off (Servo Off).

If the users desire to control electromagnetic brake via external controller, not by the servo drive, the users must execute the function of electromagnetic brake during the period of time when servo motor is braking. The braking strength of motor and electromagnetic brake must be in the same direction when servo motor is braking. Then, the servo drive will operate normally. However, the servo drive may generate larger current during acceleration or at constant speed and it may be the cause of overload (servo fault).

Timing chart for using servo motor with electromagnetic brake:

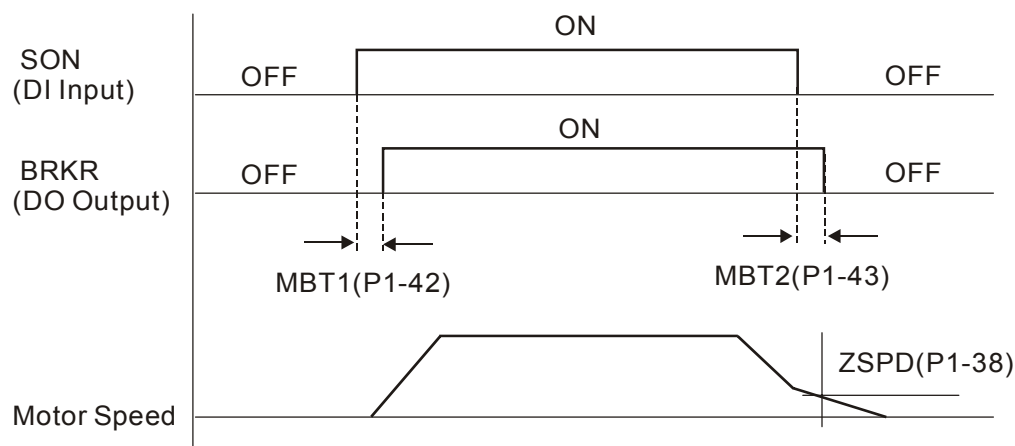

BRKR output timing explanation:

1. When SERVO OFF (when DI SON is not activated), the BRKR output goes Off (electromagnetic brake is locked) after the delay time set by P1-43 is reached and the motor speed is still higher than the setting value of P1-38.
2. When SERVO OFF (when DI SON is not activated), the BRKR output goes Off (electromagnetic brake is locked) if the delay time set by P1-43 is not reached and the motor speed is still lower than the setting value of P1-38.

Chapter 6 Control Modes of Operation | ASDA-A&A+ Series

Electromagnetic Brake Wiring Diagram

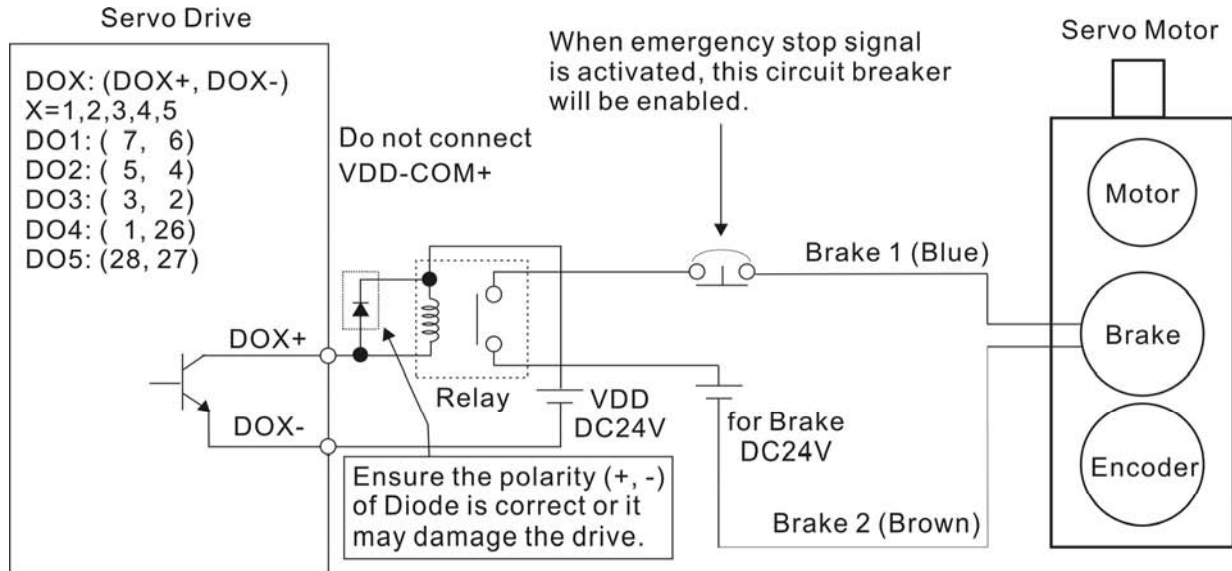

NOTE

- 1) Please refer to Chapter 3 Connections and Wiring for more wiring information.
- 2) The BRKR signal is used to control the brake operation. The VDD DC24V power supply of the servo drive can be used to power the relay coil (Relay). When BRKR signal is ON, the motor brake will be activated.
- 3) Please note that the coil of brake has no polarity.
- 4) The power supply for brake is DC24V. Never use it for VDD, the +24V source voltage.

Chapter 6 Control Modes of Operation | ASDA-A&A+ Series

The timing charts of control circuit power and main circuit power:

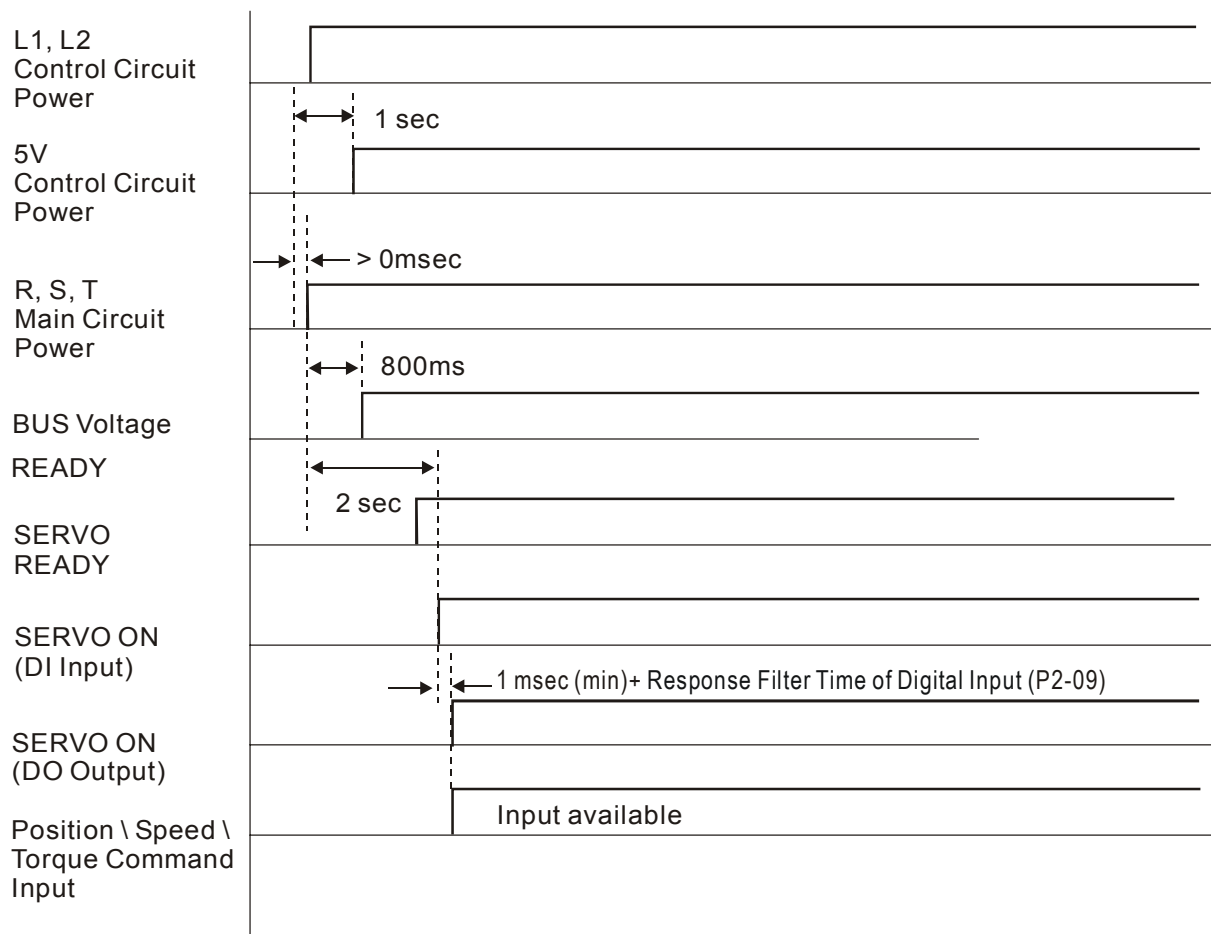

Chapter 6 Control Modes of Operation | ASDA-A&A+ Series

This page intentionally left blank.

Chapter 7 Servo Parameters

7.1 Definition

There are following five groups for drive parameters:

Group 0: Monitor parameter	(example: P0-xx)
Group 1: Basic parameter	(example: P1-xx)
Group 2: Extension parameter	(example: P2-xx)
Group 3: Communication parameter	(example: P3-xx)
Group 4: Diagnosis parameter	(example: P4-xx)

Abbreviation of control modes:

Pt	:	Position control mode (command from external signal)
Pr	:	Position control mode (command from internal signal)
S	:	Speed control mode
T	:	Torque control mode

Explanation of symbols (marked after parameter)

- (★) Read-only register, such as P0-00, P0-01, P4-00.
- (▲) Parameter cannot be set when Servo On (when the servo drive is enabled), such as P1-00, P2-32.
- (●) Parameter is effective only after the servo drive is restarted (after switching power off and on), such as P1-01, P1-33.
- (■) Parameter setting values are not retained when power is off, such as P3-06.

Chapter 7 Servo Parameters | ASDA-A&A+ Series

7.2 Parameters Summary

7.2.1 Parameters List by Group

Group 0: P0-xx

Monitor Parameters								
Parameter	Name	Function	Default	Unit	Control Mode			
					Pt	Pr	S	T
P0-00★	VER	Firmware Version	Factory setting	N/A	○	○	○	○
P0-01★	ALE	Drive Fault Code	N/A	N/A	○	○	○	○
P0-02	STS	Drive Status	00	N/A	○	○	○	○
P0-03	MON	Analog Monitor Output	01	N/A	○	○	○	○
P0-04	CM1	Status Monitor 1	0	N/A	○	○	○	○
P0-05	CM2	Status Monitor 2	0	N/A	○	○	○	○
P0-06	CM3	Status Monitor 3	0	N/A	○	○	○	○
P0-07	CM4	Status Monitor 4	0	N/A	○	○	○	○
P0-08	CM5	Status Monitor 5	0	N/A	○	○	○	○
P0-09	MAP0	Block Data Read / Write Register 0	407H	N/A	○	○	○	○
P0-10	MAP1	Block Data Read / Write Register 1	10FH	N/A	○	○	○	○
P0-11	MAP2	Block Data Read / Write Register 2	110H	N/A	○	○	○	○
P0-12	MAP3	Block Data Read / Write Register 3	224H	N/A	○	○	○	○
P0-13	MAP4	Block Data Read / Write Register 4	111H	N/A	○	○	○	○
P0-14	MAP5	Block Data Read / Write Register 5	112H	N/A	○	○	○	○
P0-15	MAP6	Block Data Read / Write Register 6	225H	N/A	○	○	○	○
P0-16	MAP7	Block Data Read / Write Register 7	109H	N/A	○	○	○	○
P0-17	SVSTS	Servo Output Status Display	N/A	N/A	○	○	○	○

Explanation of symbols (marked after parameter)

- (★) Read-only register.
- (▲) Parameter cannot be set when Servo On (when the servo drive is enabled).
- (●) Parameter is effective only after the servo drive is restarted (after switching power off and on).
- (■) Parameter setting values are not retained when power is off.

Chapter 7 Servo Parameters | ASDA-A&A+ Series

Group 1: P1-xx

Basic Parameters								
Parameter	Name	Function	Default	Unit	Control Mode			
					Pt	Pr	S	T
P1-00▲	PTT	External Pulse Input Type	2	N/A	<input type="radio"/>			
P1-01●	CTL	Control Mode and Output Direction	0	pulse r/min N-m	<input type="radio"/>	<input type="radio"/>	<input type="radio"/>	<input type="radio"/>
P1-02▲	PSTL	Speed and Torque Limit	0	N/A	<input type="radio"/>	<input type="radio"/>	<input type="radio"/>	<input type="radio"/>
P1-03	AOUT	Pulse Output Polarity Setting	0	N/A	<input type="radio"/>	<input type="radio"/>	<input type="radio"/>	<input type="radio"/>
P1-04	MON1	Analog Monitor Output Proportion 1 (CH1)	100	%	<input type="radio"/>	<input type="radio"/>	<input type="radio"/>	<input type="radio"/>
P1-05	MON2	Analog Monitor Output Proportion 2 (CH2)	100	%	<input type="radio"/>	<input type="radio"/>	<input type="radio"/>	<input type="radio"/>
P1-06	SFLT	Accel / Decel Smooth Constant of Analog Speed Command (Low-pass Filter)	0	ms			<input type="radio"/>	
P1-07	TFLT	Smooth Constant of Analog Torque Command (Low-pass Filter)	0	ms				<input type="radio"/>
P1-08	PFLT	Smooth Constant of Position Command (Low-pass Filter)	0	ms	<input type="radio"/>			
P1-09 ~ P1-11	SP1 ~ 3	1st ~ 3rd Speed Command	100 ~ 300	r/min			<input type="radio"/>	<input type="radio"/>
		1st ~ 3rd Speed Limit						
P1-12 ~ P1-14	TQ1 ~ 3	1st ~ 3rd Torque Command	100	%	<input type="radio"/>		<input type="radio"/>	<input type="radio"/>
		1st ~ 3rd Torque Limit						
P1-15 ~ P1-30	PO1H ~ PO8H	1st ~ 8th Position command for Rotation	0	N/A		<input type="radio"/>		
	PO1L ~ PO8L	1st ~ 8th Position command for Pulse	0	N/A		<input type="radio"/>		
P1-31	Reserved							
P1-32	LSTP	Motor Stop Mode Selection	0	N/A	<input type="radio"/>	<input type="radio"/>	<input type="radio"/>	<input type="radio"/>
P1-33●	POSS	Position Control Mode (Pr)	0	N/A		<input type="radio"/>		
P1-34	TACC	Acceleration Time	200	ms		<input type="radio"/>	<input type="radio"/>	
P1-35	TDEC	Deceleration Time	200	ms		<input type="radio"/>	<input type="radio"/>	
P1-36	TSL	Accel /Decel S-curve	0	ms		<input type="radio"/>	<input type="radio"/>	
P1-37	GDR	Ratio of Load Inertia to Servo Motor Inertia	5.0	times	<input type="radio"/>	<input type="radio"/>	<input type="radio"/>	<input type="radio"/>
P1-38	ZSPD	Zero Speed Range Setting	10	r/min	<input type="radio"/>	<input type="radio"/>	<input type="radio"/>	<input type="radio"/>
P1-39	SSPD	Target Motor Speed	3000	r/min	<input type="radio"/>	<input type="radio"/>	<input type="radio"/>	<input type="radio"/>
P1-40▲	VCM	Max. Analog Speed Command or Limit	rated speed	r/min			<input type="radio"/>	<input type="radio"/>
P1-41▲	TCM	Max. Analog Torque Command or Limit	100	%	<input type="radio"/>	<input type="radio"/>	<input type="radio"/>	<input type="radio"/>
P1-42	MBT1	On Delay Time of Electromagnetic Brake	0	ms	<input type="radio"/>	<input type="radio"/>	<input type="radio"/>	<input type="radio"/>

Chapter 7 Servo Parameters | ASDA-A&A+ Series

Basic Parameters								
Parameter	Name	Function	Default	Unit	Control Mode			
					Pt	Pr	S	T
P1-43	MBT2	OFF Delay Time of Electromagnetic Brake	0	ms	<input type="radio"/>	<input type="radio"/>	<input type="radio"/>	<input type="radio"/>
P1-44▲	GR1	Electronic Gear Ratio (1st Numerator) (N1)	1	pulse	<input type="radio"/>	<input type="radio"/>		
P1-45▲	GR2	Electronic Gear Ratio (Denominator)	1	pulse	<input type="radio"/>	<input type="radio"/>		
P1-46▲	GR3	Encoder Output Pulse Number	1	pulse	<input type="radio"/>	<input type="radio"/>	<input type="radio"/>	<input type="radio"/>
P1-47	HMOV	Homing Mode	00	N/A	<input type="radio"/>	<input type="radio"/>	<input type="radio"/>	<input type="radio"/>
P1-48	HSPD1	1st Speed Setting of High Speed Homing	1000	r/min	<input type="radio"/>	<input type="radio"/>	<input type="radio"/>	<input type="radio"/>
P1-49	HSPD2	2nd Speed Setting of Low Speed Homing	50	r/min	<input type="radio"/>	<input type="radio"/>	<input type="radio"/>	<input type="radio"/>
P1-50	HOF1	Homing Offset Rotation Number	0	rev	<input type="radio"/>	<input type="radio"/>	<input type="radio"/>	<input type="radio"/>
P1-51	HOF2	Homing Offset Pulse Number	0	pulse	<input type="radio"/>	<input type="radio"/>	<input type="radio"/>	<input type="radio"/>
P1-52	RES1	Regenerative Resistor Value	N/A	Ohm	<input type="radio"/>	<input type="radio"/>	<input type="radio"/>	<input type="radio"/>
P1-53	RES2	Regenerative Resistor Capacity	N/A	Watt	<input type="radio"/>	<input type="radio"/>	<input type="radio"/>	<input type="radio"/>
P1-54	PER	Positioning Completed Width	100	pulse	<input type="radio"/>	<input type="radio"/>		
P1-55	MSPD	Maximum Speed Limit	rated speed	r/min	<input type="radio"/>	<input type="radio"/>	<input type="radio"/>	<input type="radio"/>
P1-56	OVW	Output Overload Warning Time	120	%	<input type="radio"/>	<input type="radio"/>	<input type="radio"/>	<input type="radio"/>
P1-57	Reserved							
P1-58	Reserved							
P1-62	COKT	Delay Time of Internal Position Command Completed Output Signal	0	ms		<input type="radio"/>		
Parameters for ASDA-A+ series only								
P1-59	MFLT	Analog Speed Linear Filter	120	%			<input type="radio"/>	
P1-60	GR7	High Resolution Electronic Gear Ratio	7	-	<input type="radio"/>			
P1-61	GR8	High Resolution Output Pulse Number	7	-	<input type="radio"/>			

Explanation of symbols (marked after parameter)

- (★) Read-only register.
- (▲) Parameter cannot be set when Servo On (when the servo drive is enabled).
- (●) Parameter is effective only after the servo drive is restarted (after switching power off and on).
- (■) Parameter setting values are not retained when power is off.

Chapter 7 Servo Parameters | ASDA-A&A+ Series

Group 2: P2-xx

Extension Parameters								
Parameter	Name	Function	Default	Unit	Control Mode			
					Pt	Pr	S	T
P2-00	KPP	Proportional Position Loop Gain	35	rad/s	<input type="radio"/>	<input type="radio"/>	<input type="radio"/>	<input type="radio"/>
P2-01	PPR	Position Loop Gain Switching Rate	100	%	<input type="radio"/>	<input type="radio"/>	<input type="radio"/>	<input type="radio"/>
P2-02	PFG	Position Feed Forward Gain	5000	0.0001	<input type="radio"/>	<input type="radio"/>	<input type="radio"/>	<input type="radio"/>
P2-03	PFF	Smooth Constant of Position Feed Forward Gain	5	ms	<input type="radio"/>	<input type="radio"/>	<input type="radio"/>	<input type="radio"/>
P2-04	KVP	Proportional Speed Loop Gain	500	rad/s	<input type="radio"/>	<input type="radio"/>	<input type="radio"/>	<input type="radio"/>
P2-05	SPR	Speed Loop Gain Switching Rate	100	%	<input type="radio"/>	<input type="radio"/>	<input type="radio"/>	<input type="radio"/>
P2-06	KVI	Speed Integral Compensation	100	N/A	<input type="radio"/>	<input type="radio"/>	<input type="radio"/>	<input type="radio"/>
P2-07	SFG	Speed Feed Forward Gain	0	0.0001	<input type="radio"/>	<input type="radio"/>	<input type="radio"/>	<input type="radio"/>
P2-08■	PCTL	Special Factory Setting	0	N/A	<input type="radio"/>	<input type="radio"/>	<input type="radio"/>	<input type="radio"/>
P2-09	DRT	Bounce Filter	2	2ms	<input type="radio"/>	<input type="radio"/>	<input type="radio"/>	<input type="radio"/>
P2-10	DI1	Digital Input Terminal 1 (DI1)	101	N/A	<input type="radio"/>	<input type="radio"/>	<input type="radio"/>	<input type="radio"/>
P2-11	DI2	Digital Input Terminal 2 (DI2)	104	N/A	<input type="radio"/>	<input type="radio"/>	<input type="radio"/>	<input type="radio"/>
P2-12	DI3	Digital Input Terminal 3 (DI3)	116	N/A	<input type="radio"/>	<input type="radio"/>	<input type="radio"/>	<input type="radio"/>
P2-13	DI4	Digital Input Terminal 4 (DI4)	117	N/A	<input type="radio"/>	<input type="radio"/>	<input type="radio"/>	<input type="radio"/>
P2-14	DI5	Digital Input Terminal 5 (DI5)	102	N/A	<input type="radio"/>	<input type="radio"/>	<input type="radio"/>	<input type="radio"/>
P2-15	DI6	Digital Input Terminal 6 (DI6)	22	N/A	<input type="radio"/>	<input type="radio"/>	<input type="radio"/>	<input type="radio"/>
P2-16	DI7	Digital Input Terminal 7 (DI7)	23	N/A	<input type="radio"/>	<input type="radio"/>	<input type="radio"/>	<input type="radio"/>
P2-17	DI8	Digital Input Terminal 8 (DI8)	21	N/A	<input type="radio"/>	<input type="radio"/>	<input type="radio"/>	<input type="radio"/>
P2-18	DO1	Digital Output Terminal 1 (DO1)	101	N/A	<input type="radio"/>	<input type="radio"/>	<input type="radio"/>	<input type="radio"/>
P2-19	DO2	Digital Output Terminal 2 (DO2)	103	N/A	<input type="radio"/>	<input type="radio"/>	<input type="radio"/>	<input type="radio"/>
P2-20	DO3	Digital Output Terminal 3 (DO3)	109	N/A	<input type="radio"/>	<input type="radio"/>	<input type="radio"/>	<input type="radio"/>
P2-21	DO4	Digital Output Terminal 4 (DO4)	105	N/A	<input type="radio"/>	<input type="radio"/>	<input type="radio"/>	<input type="radio"/>
P2-22	DO5	Digital Output Terminal 5 (DO5)	7	N/A	<input type="radio"/>	<input type="radio"/>	<input type="radio"/>	<input type="radio"/>
P2-23	NCF	Notch Filter (Resonance Suppression)	1000	Hz	<input type="radio"/>	<input type="radio"/>	<input type="radio"/>	<input type="radio"/>
P2-24	DPH	Notch Filter Attenuation Rate (Resonance Suppression)	0	dB	<input type="radio"/>	<input type="radio"/>	<input type="radio"/>	<input type="radio"/>
P2-25	NLP	Low-pass Filter Time Constant (Resonance Suppression)	2 or 5	ms	<input type="radio"/>	<input type="radio"/>	<input type="radio"/>	<input type="radio"/>
P2-26	DST	External Anti-Interference Gain	0	0.001	<input type="radio"/>	<input type="radio"/>	<input type="radio"/>	<input type="radio"/>
P2-27	GCC	Gain Switching Control Selection	0	N/A	<input type="radio"/>	<input type="radio"/>	<input type="radio"/>	<input type="radio"/>
P2-28	GUT	Gain Switching Time Constant	10	10ms	<input type="radio"/>	<input type="radio"/>	<input type="radio"/>	<input type="radio"/>
P2-29	GPE	Gain Switching Condition	10000	pulse Kpps r/min	<input type="radio"/>	<input type="radio"/>	<input type="radio"/>	<input type="radio"/>
P2-30■	INH	Auxiliary Function	0	N/A	<input type="radio"/>	<input type="radio"/>	<input type="radio"/>	<input type="radio"/>

Chapter 7 Servo Parameters | ASDA-A&A+ Series

Extension Parameters								
Parameter	Name	Function	Default	Unit	Control Mode			
					Pt	Pr	S	T
P2-31■	AUT1	Auto Mode Responsiveness Level	44	N/A	<input type="radio"/>	<input type="radio"/>	<input type="radio"/>	<input type="radio"/>
P2-32▲	AUT2	Tuning Mode Selection	0	N/A	<input type="radio"/>	<input type="radio"/>	<input type="radio"/>	<input type="radio"/>
P2-33▲	INF	Easy Setting of Input Filter	0	N/A	<input type="radio"/>	<input type="radio"/>	<input type="radio"/>	<input type="radio"/>
P2-34	SDEV	Overspeed Warning Condition	5000	r/min			<input type="radio"/>	
P2-35	PDEV	Excessive Error Warning Condition	30000	pulse	<input type="radio"/>	<input type="radio"/>		
P2-36 ~ P2-43	POV1 ~ POV8	Moving Speed Setting of 1st ~ 8th Position	1000	r/min		<input type="radio"/>		
P2-44	DOM	Digital Output Mode Setting	0	N/A		<input type="radio"/>		
P2-45	DOD	Combination Output Signal Delay Time	1	4ms		<input type="radio"/>		
P2-46	FSN	Feed Step Number	6	N/A		<input type="radio"/>		
P2-47	PED	Position Deviation Clear Delay Time	0	20ms		<input type="radio"/>		
P2-48	BLAS	Backlash Compensation of Feed Step Control	0	pulse		<input type="radio"/>		
P2-49	SJIT	Speed Detection Filter and Jitter Suppression	0	sec	<input type="radio"/>	<input type="radio"/>	<input type="radio"/>	<input type="radio"/>
P2-50	DCLR	Pulse Deviation Clear Mode	0	N/A	<input type="radio"/>	<input type="radio"/>		
P2-51	SRON	Servo ON	0	N/A	<input type="radio"/>	<input type="radio"/>	<input type="radio"/>	<input type="radio"/>
P2-52	ATM0	Timer 0 of Auto Mode	0	sec		<input type="radio"/>		
P2-53	ATM1	Timer 1 of Auto Mode	0	sec		<input type="radio"/>		
P2-54	ATM2	Timer 2 of Auto Mode	0	sec		<input type="radio"/>		
P2-55	ATM3	Timer 3 of Auto Mode	0	sec		<input type="radio"/>		
P2-56	ATM4	Timer 4 of Auto Mode	0	sec		<input type="radio"/>		
P2-57	ATM5	Timer 5 of Auto Mode	0	sec		<input type="radio"/>		
P2-58	ATM6	Timer 6 of Auto Mode	0	sec		<input type="radio"/>		
P2-59	ATM7	Timer 7 of Auto Mode	0	sec		<input type="radio"/>		
P2-60	GR4	Electronic Gear Ratio (2nd Numerator) (N2)	1	pulse	<input type="radio"/>	<input type="radio"/>		
P2-61	GR5	Electronic Gear Ratio (3rd Numerator) (N3)	1	pulse	<input type="radio"/>	<input type="radio"/>		
P2-62	GR6	Electronic Gear Ratio (4th Numerator) (N4)	1	pulse	<input type="radio"/>	<input type="radio"/>		
P2-63	TSCA	Proportion Value Setting	0	times	<input type="radio"/>	<input type="radio"/>	<input type="radio"/>	
P2-64	TLMOD	Torque Limit Mixed Mode	0	N/A	<input type="radio"/>	<input type="radio"/>	<input type="radio"/>	
P2-65	GBIT	Special Function	0	N/A	<input type="radio"/>	<input type="radio"/>	<input type="radio"/>	

Explanation of symbols (marked after parameter)

- (★) Read-only register.
- (▲) Parameter cannot be set when Servo On (when the servo drive is enabled).
- (●) Parameter is effective only after the servo drive is restarted (after switching power off and on).
- (■) Parameter setting values are not retained when power is off.

Chapter 7 Servo Parameters | ASDA-A&A+ Series

Group 3: P3-xx

Communication Parameters								
Parameter	Name	Function	Default	Unit	Control Mode			
					Pt	Pr	S	T
P3-00	ADR	Communication Address Setting	1	N/A	<input type="radio"/>	<input type="radio"/>	<input type="radio"/>	<input type="radio"/>
P3-01	BRT	Transmission Speed	1	bps	<input type="radio"/>	<input type="radio"/>	<input type="radio"/>	<input type="radio"/>
P3-02	PTL	Communication Protocol	0	N/A	<input type="radio"/>	<input type="radio"/>	<input type="radio"/>	<input type="radio"/>
P3-03	FLT	Transmission Fault Treatment	0	N/A	<input type="radio"/>	<input type="radio"/>	<input type="radio"/>	<input type="radio"/>
P3-04	CWD	Communication Time Out Detection	0	sec	<input type="radio"/>	<input type="radio"/>	<input type="radio"/>	<input type="radio"/>
P3-05	CMM	Communication Selection	0	N/A	<input type="radio"/>	<input type="radio"/>	<input type="radio"/>	<input type="radio"/>
P3-06 ■	SDI	Digital Input Communication Function	0	N/A	<input type="radio"/>	<input type="radio"/>	<input type="radio"/>	<input type="radio"/>
P3-07	CDT	Communication Response Delay Time	0	0.5ms	<input type="radio"/>	<input type="radio"/>	<input type="radio"/>	<input type="radio"/>

Explanation of symbols (marked after parameter)

- (★) Read-only register.
- (▲) Parameter cannot be set when Servo On (when the servo drive is enabled).
- (●) Parameter is effective only after the servo drive is restarted (after switching power off and on).
- (■) Parameter setting values are not retained when power is off.

Chapter 7 Servo Parameters | ASDA-A&A+ Series**Group 4: P4-xx**

Diagnosis Parameters								
Parameter	Name	Function	Default	Unit	Control Mode			
					Pt	Pr	S	T
P4-00★	ASH1	Fault Record (N)	0	N/A	<input type="radio"/>	<input type="radio"/>	<input type="radio"/>	<input type="radio"/>
P4-01★	ASH2	Fault Record (N-1)	0	N/A	<input type="radio"/>	<input type="radio"/>	<input type="radio"/>	<input type="radio"/>
P4-02★	ASH3	Fault Record (N-2)	0	N/A	<input type="radio"/>	<input type="radio"/>	<input type="radio"/>	<input type="radio"/>
P4-03★	ASH4	Fault Record (N-3)	0	N/A	<input type="radio"/>	<input type="radio"/>	<input type="radio"/>	<input type="radio"/>
P4-04★	ASH5	Fault Record (N-4)	0	N/A	<input type="radio"/>	<input type="radio"/>	<input type="radio"/>	<input type="radio"/>
P4-05	JOG	JOG Operation	20	r/min	<input type="radio"/>	<input type="radio"/>	<input type="radio"/>	<input type="radio"/>
P4-06▲■	FOT	Force Output Control	0	N/A	<input type="radio"/>	<input type="radio"/>	<input type="radio"/>	<input type="radio"/>
P4-07■	ITST	Input Status or Force Input Control	N/A	N/A	<input type="radio"/>	<input type="radio"/>	<input type="radio"/>	<input type="radio"/>
P4-08	PKEY	Digital Keypad Input of Servo Drive	N/A	N/A	<input type="radio"/>	<input type="radio"/>	<input type="radio"/>	<input type="radio"/>
P4-09★	MOT	Output Status Display	N/A	N/A	<input type="radio"/>	<input type="radio"/>	<input type="radio"/>	<input type="radio"/>
P4-10▲	CEN	Adjustment Function	0	N/A	<input type="radio"/>	<input type="radio"/>	<input type="radio"/>	<input type="radio"/>
P4-11	SOF1	Analog Speed Input Drift Adjustment 1	Factory setting	N/A	<input type="radio"/>	<input type="radio"/>	<input type="radio"/>	<input type="radio"/>
P4-12	SOF2	Analog Speed Input Drift Adjustment 2	Factory setting	N/A	<input type="radio"/>	<input type="radio"/>	<input type="radio"/>	<input type="radio"/>
P4-13	TOF1	Analog Torque Drift Adjustment 1	Factory setting	N/A	<input type="radio"/>	<input type="radio"/>	<input type="radio"/>	<input type="radio"/>
P4-14	TOF2	Analog Torque Drift Adjustment 2	Factory setting	N/A	<input type="radio"/>	<input type="radio"/>	<input type="radio"/>	<input type="radio"/>
P4-15	COF1	Current Detector Drift Adjustment (V1 phase)	Factory setting	N/A	<input type="radio"/>	<input type="radio"/>	<input type="radio"/>	<input type="radio"/>
P4-16	COF2	Current Detector Drift Adjustment (V2 phase)	Factory setting	N/A	<input type="radio"/>	<input type="radio"/>	<input type="radio"/>	<input type="radio"/>
P4-17	COF3	Current Detector Drift Adjustment (W1 phase)	Factory setting	N/A	<input type="radio"/>	<input type="radio"/>	<input type="radio"/>	<input type="radio"/>
P4-18	COF4	Current Detector Drift Adjustment (W2 phase)	Factory setting	N/A	<input type="radio"/>	<input type="radio"/>	<input type="radio"/>	<input type="radio"/>
P4-19	TIGB	IGBT NTC Calibration	Factory setting	N/A	<input type="radio"/>	<input type="radio"/>	<input type="radio"/>	<input type="radio"/>
P4-20	DOF1	Analog Monitor Output Drift Adjustment (CH1)	0	mV	<input type="radio"/>	<input type="radio"/>	<input type="radio"/>	<input type="radio"/>
P4-21	DOF2	Analog Monitor Output Drift Adjustment (CH2)	0	mV	<input type="radio"/>	<input type="radio"/>	<input type="radio"/>	<input type="radio"/>
P4-22	SAO	Analog Speed Input Offset	0	mV			<input type="radio"/>	
P4-23	TAO	Analog Torque Input Offset	0	mV				<input type="radio"/>

Chapter 7 Servo Parameters | ASDA-A&A+ Series

7.2.2 Parameters List by Function

Monitor and General Use									
Parameter	Name	Function	Default	Unit	Control Mode				Related Section of User Manual
					Pt	Pr	S	T	
P0-00★	VER	Firmware Version	Factory setting	N/A	○	○	○	○	---
P0-01★	ALE	Drive Fault Code	N/A	N/A	○	○	○	○	10.1
P0-02	STS	Drive Status	00	N/A	○	○	○	○	4.3.5
P0-03	MON	Analog Monitor Output	01	N/A	○	○	○	○	4.3.5
P0-04	CM1	Status Monitor 1	0	N/A	○	○	○	○	4.3.5
P0-05	CM2	Status Monitor 2	0	N/A	○	○	○	○	4.3.5
P0-06	CM3	Status Monitor 3	0	N/A	○	○	○	○	4.3.5
P0-07	CM4	Status Monitor 4	0	N/A	○	○	○	○	4.3.5
P0-08	CM5	Status Monitor 5	0	N/A	○	○	○	○	4.3.5
P0-09	MAP0	Block Data Read / Write Register 0	407H	N/A	○	○	○	○	---
P0-10	MAP1	Block Data Read / Write Register 1	10FH	N/A	○	○	○	○	---
P0-11	MAP2	Block Data Read / Write Register 2	110H	N/A	○	○	○	○	---
P0-12	MAP3	Block Data Read / Write Register 3	224H	N/A	○	○	○	○	---
P0-13	MAP4	Block Data Read / Write Register 4	111H	N/A	○	○	○	○	---
P0-14	MAP5	Block Data Read / Write Register 5	112H	N/A	○	○	○	○	---
P0-15	MAP6	Block Data Read / Write Register 6	225H	N/A	○	○	○	○	---
P0-16	MAP7	Block Data Read / Write Register 7	109H	N/A	○	○	○	○	---
P0-17	SVSTS	Servo Output Status Display	N/A	N/A	○	○	○	○	---
P1-03	AOUT	Pulse Output Polarity Setting	0	N/A	○	○	○	○	3.3.3
P1-04	MON1	Analog Monitor Output Proportion 1 (CH1)	100	%	○	○	○	○	6.4.4
P1-05	MON2	Analog Monitor Output Proportion 2 (CH2)	100	%	○	○	○	○	6.4.4

Explanation of symbols (marked after parameter)

- (★) Read-only register.
- (▲) Parameter cannot be set when Servo On (when the servo drive is enabled).
- (●) Parameter is effective only after the servo drive is restarted (after switching power off and on).
- (■) Parameter setting values are not retained when power is off.

Chapter 7 Servo Parameters | ASDA-A&A+ Series

Smooth Filter and Resonance Suppression									
Parameter	Name	Function	Default	Unit	Control Mode				Related Section of User Manual
					Pt	Pr	S	T	
P1-06	SFLT	Accel / Decel Smooth Constant of Analog Speed Command (Low-pass Filter)	0	ms				○	6.3.3
P1-07	TFLT	Smooth Constant of Analog Torque Command (Low-pass Filter)	0	ms			○		6.4.3
P1-08	PFLT	Smooth Constant of Position Command (Low-pass Filter)	0	ms	○				6.2.6
P1-34	TACC	Acceleration Time	200	ms		○	○		6.3.3
P1-35	TDEC	Deceleration Time	200	ms		○	○		6.3.3
P1-36	TSL	Accel /Decel S-curve	0	ms		○	○		6.2.4 6.3.3
P2-23	NCF	Notch Filter (Resonance Suppression)	1000	Hz	○	○	○	○	6.3.7
P2-24	DPH	Notch Filter Attenuation Rate (Resonance Suppression)	0	dB	○	○	○	○	6.3.7
P2-25	NLP	Low-pass Filter Time Constant (Resonance Suppression)	2 or 5	ms	○	○	○	○	6.3.7
P2-33▲	INF	Easy Setting of Input Filter	0	N/A	○	○	○	○	6.3.6
P2-49	SJIT	Speed Detection Filter and Jitter Suppression	0	sec	○	○	○	○	---

Explanation of symbols (marked after parameter)

- (★) Read-only register.
- (▲) Parameter cannot be set when Servo On (when the servo drive is enabled).
- (●) Parameter is effective only after the servo drive is restarted (after switching power off and on).
- (■) Parameter setting values are not retained when power is off.

Chapter 7 Servo Parameters | ASDA-A&A+ Series

Gain and Switch									
Parameter	Name	Function	Default	Unit	Control Mode				Related Section of User Manual
					Pt	Pr	S	T	
P2-00	KPP	Proportional Position Loop Gain	35	rad/s	○	○			6.2.8
P2-01	PPR	Position Loop Gain Switching Rate	100	%	○	○			---
P2-02	PFG	Position Feed Forward Gain	5000	0.0001	○	○			6.2.8
P2-03	PFF	Smooth Constant of Position Feed Forward Gain	5	ms	○	○			---
P2-04	KVP	Proportional Speed Loop Gain	500	rad/s	○	○	○	○	6.3.6
P2-05	SPR	Speed Loop Gain Switching Rate	100	%	○	○	○	○	---
P2-06	KVI	Speed Integral Compensation	100	N/A	○	○	○	○	6.3.6
P2-07	SFG	Speed Feed Forward Gain	0	0.0001		○	○	○	6.3.6
P2-26	DST	External Anti-Interference Gain	0	0.001	○	○	○	○	---
P2-27	GCC	Gain Switching Control Selection	0	N/A	○	○	○	○	---
P2-28	GUT	Gain Switching Time Constant	10	10ms	○	○	○	○	---
P2-29	GPE	Gain Switching Condition	10000	pulse Kpps r/min	○	○	○	○	---
P2-31	AUT1	Auto Mode Responsiveness Level	44	N/A	○	○	○	○	6.3.6
P2-32	AUT2	Tuning Mode Selection	0	N/A	○	○	○	○	6.3.6

Explanation of symbols (marked after parameter)

- (★) Read-only register.
- (▲) Parameter cannot be set when Servo On (when the servo drive is enabled).
- (●) Parameter is effective only after the servo drive is restarted (after switching power off and on).
- (■) Parameter setting values are not retained when power is off.

Chapter 7 Servo Parameters | ASDA-A&A+ Series

Position Control									
Parameter	Name	Function	Default	Unit	Control Mode				Related Section of User Manual
					Pt	Pr	S	T	
P1-01●	CTL	Control Mode and Output Direction	0	pulse r/min N-m	○	○	○	○	6.1
P1-02▲	PSTL	Speed and Torque Limit	0	N/A	○	○	○	○	6.6
P1-46▲	GR3	Encoder Output Pulse Number	1	pulse	○	○	○	○	---
P1-55	MSPD	Maximum Speed Limit	rated speed	r/min	○	○	○	○	---
P1-12 ~ P1-14	TQ1 ~ 3	1st ~ 3rd Torque Command 1st ~ 3rd Torque Limit	100	%	○	○	○	○	6.4.1
P2-50	DCLR	Pulse Deviation Clear Mode	0	N/A	○	○			---
External pulse control command (Pt mode)									
P1-00▲	PTT	External Pulse Input Type	2	N/A	○				6.2.1
P1-44▲	GR1	Electronic Gear Ratio (1st Numerator) (N1)	1	pulse	○	○			6.2.5
P1-45▲	GR2	Electronic Gear Ratio (Denominator)	1	pulse	○	○			6.3.6
P2-60	GR4	Electronic Gear Ratio (2nd Numerator) (N2)	1	pulse	○	○			Table 7.A
P2-61	GR5	Electronic Gear Ratio (3rd Numerator) (N3)	1	pulse	○	○			Table 7.A
P2-62	GR6	Electronic Gear Ratio (4th Numerator) (N4)	1	pulse	○	○			Table 7.A
Internal pulse control command (Pr mode)									
P1-15 ~ P1-30	PO1H ~ PO8H	1st ~ 8th Position command for Rotation	0	N/A	○				6.2.2
	PO1L ~ PO8L	1st ~ 8th Position command for Pulse							
P2-36 ~ P2-43	POV1 ~ POV8	Moving Speed Setting of 1st ~ 8th Position	1000	r/min	○				6.2.2
P1-33●	POSS	Position Control Mode (Pr)	0	N/A	○				6.2.2
P1-47	HMOV	Homing Mode	00	N/A	○	○	○	○	12.8
P1-48	HSPD1	1st Speed Setting of High Speed Homing	1000	r/min	○	○	○	○	12.8
P1-49	HSPD2	2nd Speed Setting of Low Speed Homing	50	r/min	○	○	○	○	12.8
P1-50	HOF1	Homing Offset Rotation Number	0	rev	○	○	○	○	---
P1-51	HOF2	Homing Offset Pulse Number	0	pulse	○	○	○	○	---
P1-62	COKT	Delay Time of Internal Position Command Completed Output Signal	0	ms	○				---

Chapter 7 Servo Parameters | ASDA-A&A+ Series

Position Control									
Parameter	Name	Function	Default	Unit	Control Mode				Related Section of User Manual
					Pt	Pr	S	T	
P2-45	DOD	Combination Output Signal Delay Time	1	4ms		○			12.6
P2-46	FSN	Feed Step Number	6	N/A		○			12.6
P2-47	PED	Position Deviation Clear Delay Time	0	20ms		○			12.6
P2-48	BLAS	Backlash Compensation of Feed Step Control	0	pulse		○			12.6
P2-52	ATM0	Timer 0 of Auto Mode	0	sec		○			12.6
P2-53	ATM1	Timer 1 of Auto Mode	0	sec		○			---
P2-54	ATM2	Timer 2 of Auto Mode	0	sec		○			---
P2-55	ATM3	Timer 3 of Auto Mode	0	sec		○			---
P2-56	ATM4	Timer 4 of Auto Mode	0	sec		○			---
P2-57	ATM5	Timer 5 of Auto Mode	0	sec		○			---
P2-58	ATM6	Timer 6 of Auto Mode	0	sec		○			---
P2-59	ATM7	Timer 7 of Auto Mode	0	sec					---

Explanation of symbols (marked after parameter)

- (★) Read-only register.
- (▲) Parameter cannot be set when Servo On (when the servo drive is enabled).
- (●) Parameter is effective only after the servo drive is restarted (after switching power off and on).
- (■) Parameter setting values are not retained when power is off.

Chapter 7 Servo Parameters | ASDA-A&A+ Series

Speed Control									
Parameter	Name	Function	Default	Unit	Control Mode				Related Section of User Manual
					Pt	Pr	S	T	
P1-01●	CTL	Control Mode and Output Direction	0	pulse r/min N-m	○	○	○	○	6.1
P1-02▲	PSTL	Speed and Torque Limit	0	N/A	○	○	○	○	6.6
P1-46▲	GR3	Encoder Output Pulse Number	1	pulse	○	○	○	○	---
P1-55	MSPD	Maximum Speed Limit	rated speed	r/min	○	○	○	○	---
P1-09 ~ P1-11	SP1 ~ 3	1st ~ 3rd Speed Command 1st ~ 3rd Speed Limit	100 ~ 300	r/min			○	○	6.3.1
P1-12 ~ P1-14	TQ1 ~ 3	1st ~ 3rd Torque Command 1st ~ 3rd Torque Limit	100	%	○	○	○	○	6.6.2
P1-40▲	VCM	Max. Analog Speed Command or Limit	rated speed	r/min			○	○	6.3.4
P1-41▲	TCM	Max. Analog Torque Command or Limit	100	%	○	○	○	○	---
P2-63	TSCA	Proportion Value Setting	0	times	○	○	○		---
P2-64	TLMOD	Torque Limit Mixed Mode	0	N/A	○	○	○		---

Explanation of symbols (marked after parameter)

- (★) Read-only register.
- (▲) Parameter cannot be set when Servo On (when the servo drive is enabled).
- (●) Parameter is effective only after the servo drive is restarted (after switching power off and on).
- (■) Parameter setting values are not retained when power is off.

Chapter 7 Servo Parameters | ASDA-A&A+ Series

Torque Control									
Parameter	Name	Function	Default	Unit	Control Mode				Related Section of User Manual
					Pt	Pr	S	T	
P1-01●	CTL	Control Mode and Output Direction	0	pulse r/min N-m	<input type="radio"/>	<input type="radio"/>	<input type="radio"/>	<input type="radio"/>	6.1
P1-02▲	PSTL	Speed and Torque Limit	0	N/A	<input type="radio"/>	<input type="radio"/>	<input type="radio"/>	<input type="radio"/>	6.6
P1-46▲	GR3	Encoder Output Pulse Number	1	pulse	<input type="radio"/>	<input type="radio"/>	<input type="radio"/>	<input type="radio"/>	---
P1-55	MSPD	Maximum Speed Limit	rated speed	r/min	<input type="radio"/>	<input type="radio"/>	<input type="radio"/>	<input type="radio"/>	---
P1-09 ~ P1-11	SP1 ~ 3	1st ~ 3rd Speed Command 1st ~ 3rd Speed Limit	100 ~ 300	r/min			<input type="radio"/>	<input type="radio"/>	6.6.1
P1-12 ~ P1-14	TQ1 ~ 3	1st ~ 3rd Torque Command 1st ~ 3rd Torque Limit	100	%	<input type="radio"/>	<input type="radio"/>	<input type="radio"/>	<input type="radio"/>	6.4.1
P1-40▲	VCM	Max. Analog Speed Command or Limit	rated speed	r/min			<input type="radio"/>	<input type="radio"/>	---
P1-41▲	TCM	Max. Analog Torque Command or Limit	100	%	<input type="radio"/>	<input type="radio"/>	<input type="radio"/>	<input type="radio"/>	6.4.4

Explanation of symbols (marked after parameter)

- (★) Read-only register.
- (▲) Parameter cannot be set when Servo On (when the servo drive is enabled).
- (●) Parameter is effective only after the servo drive is restarted (after switching power off and on).
- (■) Parameter setting values are not retained when power is off.

Chapter 7 Servo Parameters | ASDA-A&A+ Series

Digital I/O and relative input output setting

Digital I/O									
Parameter	Name	Function	Default	Unit	Control Mode				Related Section of User Manual
					Pt	Pr	S	T	
P2-09	DRT	Bounce Filter	2	2ms	○	○	○	○	Table 7.A
P2-10	DI1	Digital Input Terminal 1 (DI1)	101	N/A	○	○	○	○	
P2-11	DI2	Digital Input Terminal 2 (DI2)	104	N/A	○	○	○	○	
P2-12	DI3	Digital Input Terminal 3 (DI3)	116	N/A	○	○	○	○	
P2-13	DI4	Digital Input Terminal 4 (DI4)	117	N/A	○	○	○	○	
P2-14	DI5	Digital Input Terminal 5 (DI5)	102	N/A	○	○	○	○	
P2-15	DI6	Digital Input Terminal 6 (DI6)	22	N/A	○	○	○	○	
P2-16	DI7	Digital Input Terminal 7 (DI7)	23	N/A	○	○	○	○	
P2-17	DI8	Digital Input Terminal 8 (DI8)	21	N/A	○	○	○	○	Table 7.B
P2-18	DO1	Digital Output Terminal 1 (DO1)	101	N/A	○	○	○	○	
P2-19	DO2	Digital Output Terminal 2 (DO2)	103	N/A	○	○	○	○	
P2-20	DO3	Digital Output Terminal 3 (DO3)	109	N/A	○	○	○	○	
P2-21	DO4	Digital Output Terminal 4 (DO4)	105	N/A	○	○	○	○	
P2-22	DO5	Digital Output Terminal 5 (DO5)	7	N/A	○	○	○	○	
P1-38	ZSPD	Zero Speed Range Setting	10	r/min	○	○	○	○	
P1-39	SSPD	Target Motor Speed	3000	r/min	○	○	○	○	
P1-42	MBT1	On Delay Time of Electromagnetic Brake	0	ms	○	○	○	○	6.6.5
P1-43	MBT2	OFF Delay Time of Electromagnetic Brake	0	ms	○	○	○	○	6.6.5
P1-54	PER	Positioning Completed Width	100	pulse	○	○			---
P1-56	OVW	Output Overload Warning Time	120	%	○	○	○	○	---

Explanation of symbols (marked after parameter)

- (★) Read-only register.
- (▲) Parameter cannot be set when Servo On (when the servo drive is enabled).
- (●) Parameter is effective only after the servo drive is restarted (after switching power off and on).
- (■) Parameter setting values are not retained when power is off.

Chapter 7 Servo Parameters | ASDA-A&A+ Series

Communication									
Parameter	Name	Function	Default	Unit	Control Mode				Related Section of User Manual
					Pt	Pr	S	T	
P3-00	ADR	Communication Address Setting	1	N/A	○	○	○	○	8.2
P3-01	BRT	Transmission Speed	1	bps	○	○	○	○	8.2
P3-02	PTL	Communication Protocol	0	N/A	○	○	○	○	8.2
P3-03	FLT	Transmission Fault Treatment	0	N/A	○	○	○	○	8.2
P3-04	CWD	Communication Time Out Detection	0	sec	○	○	○	○	8.2
P3-05	CMM	Communication Selection	0	N/A	○	○	○	○	8.2
P3-06■	SDI	Digital Input Communication Function	0	N/A	○	○	○	○	8.2
P3-07	CDT	Communication Response Delay Time	0	0.5ms	○	○	○	○	---

Explanation of symbols (marked after parameter)

- (★) Read-only register.
- (▲) Parameter cannot be set when Servo On (when the servo drive is enabled).
- (●) Parameter is effective only after the servo drive is restarted (after switching power off and on).
- (■) Parameter setting values are not retained when power is off.

Chapter 7 Servo Parameters | ASDA-A&A+ Series

Diagnosis									
Parameter	Name	Function	Default	Unit	Control Mode				Related Section of User Manual
					Pt	Pr	S	T	
P4-00★	ASH1	Fault Record (N)	0	N/A	○	○	○	○	4.4.1
P4-01★	ASH2	Fault Record (N-1)	0	N/A	○	○	○	○	4.4.1
P4-02★	ASH3	Fault Record (N-2)	0	N/A	○	○	○	○	4.4.1
P4-03★	ASH4	Fault Record (N-3)	0	N/A	○	○	○	○	4.4.1
P4-04★	ASH5	Fault Record (N-4)	0	N/A	○	○	○	○	4.4.1
P4-05	JOG	JOG Operation	20	r/min	○	○	○	○	4.4.2
P4-06▲■	FOT	Force Output Control	0	N/A	○	○	○	○	4.4.4
P4-07■	ITST	Input Status or Force Input Control	N/A	N/A	○	○	○	○	4.4.5
P4-08	PKEY	Digital Keypad Input of Servo Drive	N/A	N/A	○	○	○	○	---
P4-09★	MOT	Output Status Display	N/A	N/A	○	○	○	○	4.4.6
P4-10▲	CEN	Adjustment Function	0	N/A	○	○	○	○	---
P4-11	SOF1	Analog Speed Input Drift Adjustment 1	Factory setting	N/A	○	○	○	○	---
P4-12	SOF2	Analog Speed Input Drift Adjustment 2	Factory setting	N/A	○	○	○	○	---
P4-13	TOF1	Analog Torque Drift Adjustment 1	Factory setting	N/A	○	○	○	○	---
P4-14	TOF2	Analog Torque Drift Adjustment 2	Factory setting	N/A	○	○	○	○	---
P4-15	COF1	Current Detector Drift Adjustment (V1 phase)	Factory setting	N/A	○	○	○	○	---
P4-16	COF2	Current Detector Drift Adjustment (V2 phase)	Factory setting	N/A	○	○	○	○	---
P4-17	COF3	Current Detector Drift Adjustment (W1 phase)	Factory setting	N/A	○	○	○	○	---
P4-18	COF4	Current Detector Drift Adjustment (W2 phase)	Factory setting	N/A	○	○	○	○	---
P4-19	TIGB	IGBT NTC Calibration	Factory setting	N/A	○	○	○	○	---
P4-20	DOF1	Analog Monitor Output Drift Adjustment (CH1)	0	mV	○	○	○	○	6.4.4
P4-21	DOF2	Analog Monitor Output Drift Adjustment (CH2)	0	mV	○	○	○	○	6.4.4
P4-22	SAO	Analog Speed Input Offset	0	mV			○		---
P4-23	TAO	Analog Torque Input Offset	0	mV				○	---

Chapter 7 Servo Parameters | ASDA-A&A+ Series

Others									
Parameter	Name	Function	Default	Unit	Control Mode				Related Section of User Manual
					Pt	Pr	S	T	
P1-31	Reserved								
P1-32	LSTP	Motor Stop Mode Selection	0	N/A	○	○	○	○	---
P1-37	GDR	Ratio of Load Inertia to Servo Motor Inertia	5.0	times	○	○	○	○	6.3.6
P1-52	RES1	Regenerative Resistor Value	N/A	Ohm	○	○	○	○	6.6.3
P1-53	RES2	Regenerative Resistor Capacity	N/A	Watt	○	○	○	○	6.6.3
P1-57	Reserved								
P1-58	Reserved								
P2-08■	PCTL	Special Factory Setting	0	N/A	○	○	○	○	---
P2-30■	INH	Auxiliary Function	0	N/A	○	○	○	○	---
P2-34	SDEV	Overspeed Warning Condition	5000	r/min			○		---
P2-35	PDEV	Excessive Error Warning Condition	30000	pulse	○	○			---
P2-51	SRON	Servo ON	0	N/A	○	○	○	○	12.6
P2-63	TSCA	Proportion Value Setting	0	times	○	○	○		---
P2-65	GBIT	Special Function	0	N/A	○	○	○		---
Parameters for ASDA-A+ series only									
P1-59	MFLT	Analog Speed Linear Filter	120	%			○		---
P1-60	GR7	High Resolution Electronic Gear Ratio	7	-	○				6.2.3
P1-61	GR8	High Resolution Output Pulse Number	7	-	○				---

Explanation of symbols (marked after parameter)

- (★) Read-only register.
- (▲) Parameter cannot be set when Servo On (when the servo drive is enabled).
- (●) Parameter is effective only after the servo drive is restarted (after switching power off and on).
- (■) Parameter setting values are not retained when power is off.

Chapter 7 Servo Parameters | ASDA-A&A+ Series**7.3 Detailed Parameter Listings****Group 0: P0-xx Monitor Parameters**

P0 - 00★	VER	Firmware Version	Communication Addr.: 0000H
-----------------	------------	-------------------------	-----------------------------------

Default: Factory setting

Related Section: N/A

Applicable Control Mode: ALL

Unit: N/A

Range: N/A

P0 - 01★	ALE	Drive Fault Code	Communication Addr.: 0001H
-----------------	------------	-------------------------	-----------------------------------

Default: Factory setting

Related Section:

Applicable Control Mode: ALL

Chapter 10

Unit: N/A

Range: 00 ~ 23 (ASDA-A series)

00 ~ 25 (ASDA-A+ series)

Settings:

01: Overcurrent

21: DSP to MCU command write-in error

02: Overvoltage

22: Input power phase loss

03: Undervoltage

23: Pre-overload warning

04: Reserved (ASDA-A Series)

24: Encoder Error (ASDA-A+ Series only)

"Mismatch" error (ASDA-A+ Series)

25: Encoder Error (ASDA-A+ Series only)

05: Regeneration error

06: Overload

07: Overspeed

08: Abnormal pulse control command

09: Excessive deviation

10: Watch dog fault

11: Position detector fault

12: Adjustment error

13: Emergency stop

14: Reverse limit error

15: Forward limit error

16: IGBT temperature error

17: Memory error

18: DSP communication error

19: Serial communication error

20: Serial communication time out

Chapter 7 Servo Parameters | ASDA-A&A+ Series

P0 - 02	STS	Drive Status	Communication Addr.: 0002H
		Default: 00 Applicable Control Mode: ALL Unit: N/A Range: 00 ~ 16 (ASDA-A series) 00 ~ 19 (ASDA-A+ series) Settings: 00: Motor feedback pulse number (absolute value) [pulse] 01: Motor feedback rotation number (absolute value) [rev] 02: Pulse counts of pulse command [pulse] 03: Rotation number of pulse command [rev] 04: Position error counts [pulse] 05: Input frequency of pulse command [r/min] (ASDA-A series) Input frequency of pulse command [Kpps] (ASDA-A+ series) 06: Motor speed [r/min] 07: Speed input command [Volt] 08: Speed input command [r/min] 09: Torque input command [Volt] 10: Torque input command [%] 11: Average load [%] 12: Peak load [%] 13: Main circuit voltage [Volt] 14: Ratio of load inertia to motor inertia [time] 15: Motor feedback pulse number (relative value) / Position latch pulse number [pulse] 16: Motor feedback rotation number (relative value) / Position latch rotation number [rev] 17: Reserved (ASDA-A+ series only) 18: High resolution pulse number [pulse] (ASDA-A+ series only) 19: Absolute pulse number (use Z pulse as home) [pulse] (ASDA-A+ series only)	Related Section: Section 4.3.5

Chapter 7 Servo Parameters | ASDA-A&A+ Series

P0 - 03	MON	Analog Monitor Output	Communication Addr.: 0003H
----------------	------------	------------------------------	-----------------------------------

Default: 01

Related Section:

Applicable Control Mode: ALL

Section 4.3.5

Unit: N/A

Range: 00 ~ 55

Settings:

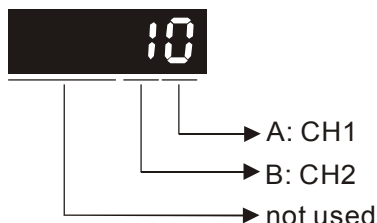

AB: (A: CH1; B: CH2)

0: Motor speed (+/-8V / maximum motor speed)

1: Motor torque (+/-8V / maximum torque)

2: Pulse command frequency (+8Volts / 650Kpps) (ASDA-A series)

Pulse command frequency (+8Volts / 4.5Mpps) (ASDA-A+ series)

3: Speed command (+/-8Volts / maximum speed command)

4: Torque command (+/-8Volts / maximum torque command)

5: V_BUS voltage (+/-8Volts / 450V)

Note: For the setting of analog output voltage proportion, refer to the P1-04 and P1-05.

Example:

P0-03 = 01(CH1 is speed analog output)

Motor speed = (Max. motor speed × V1/8) × P1-04/100, when the output voltage value of CH1 is V1.

P0 - 04	CM1	Status Monitor 1	Communication Addr.: 0004H
----------------	------------	-------------------------	-----------------------------------

Default: 0

Related Section:

Applicable Control Mode: ALL

Section 4.3.5

Unit: N/A

Range: 0 ~ 16

Settings:

Select the desired drive status through communication setting or the keypad (please refer to P0-02). The drive status can be read from the communication address of this parameter via communication port.

For example:

Set P0-04 to 1 and then all consequent reads of P0-04 will return the motor feedback rotation number in revolution.

Chapter 7 Servo Parameters | ASDA-A&A+ Series

P0 - 05	CM2	Status Monitor 2	Communication Addr.: 0005H
Default: 0		Related Section:	
Applicable Control Mode: ALL		Section 4.3.5	
Unit: N/A			
Range: 0 ~ 16			
Settings: See P0-04 for explanation.			

P0 - 06	CM3	Status Monitor 3	Communication Addr.: 0006H
Default: 0		Related Section:	
Applicable Control Mode: ALL		Section 4.3.5	
Unit: N/A			
Range: 0 ~ 16			
Settings: See P0-04 for explanation.			

P0 - 07	CM4	Status Monitor 4	Communication Addr.: 0007H
Default: 0		Related Section:	
Applicable Control Mode: ALL		Section 4.3.5	
Unit: N/A			
Range: 0 ~ 17			
Settings:			
Select the desired drive status through communication setting or the keypad (please refer to P0-02). The drive status can be read from the communication address of this parameter via communication port. If users set this parameter to 17, the status of DI signal can be read.			

P0 - 08	CM5	Status Monitor 5	Communication Addr.: 0008H
Default: 0		Related Section:	
Applicable Control Mode: ALL		Section 4.3.5	
Unit: N/A			
Range: 0 ~ 17			
Settings:			
Select the desired drive status through communication setting or the keypad (please refer to P0-02). The drive status can be read from the communication address of this parameter via communication port. If users set this parameter to 17, the status of DO signal can be read.			

Chapter 7 Servo Parameters | ASDA-A&A+ Series

P0 - 09	MAP0	Block Data Read / Write Register 0	Communication Addr.: 0009H
----------------	-------------	---	-----------------------------------

Default: 407H

Related Section: N/A

Applicable Control Mode: ALL

Unit: N/A

Range: 100H ~ 417H

Settings:

Set the register address in HEX that users want to read and write by using the keypad.

Users can enter the desired register address (0100H ~ 0417H) into P0-09 to P0-16 (0009H ~ 0010H). Then, users can read and write up to 8 continuous specified block data from the communication address 0009H to 0010H through the communication port.

For example, if setting P0-09 to 407 by using the keypad, when the users read and write the data from communication address 0009H, it means that the read and write value is the setting value of parameter P4-07.

P0 - 10	MAP1	Block Data Read / Write Register 1	Communication Addr.: 000AH
----------------	-------------	---	-----------------------------------

Default: 10FH

Related Section: N/A

Applicable Control Mode: ALL

Unit: N/A

Range: 100H ~ 417H

Settings: See P0-09 for explanation.

P0 - 11	MAP2	Block Data Read / Write Register 2	Communication Addr.: 000BH
----------------	-------------	---	-----------------------------------

Default: 110H

Related Section: N/A

Applicable Control Mode: ALL

Unit: N/A

Range: 100H ~ 417H

Settings: See P0-09 for explanation.

P0 - 12	MAP3	Block Data Read / Write Register 3	Communication Addr.: 000CH
----------------	-------------	---	-----------------------------------

Default: 224H

Related Section: N/A

Applicable Control Mode: ALL

Unit: N/A

Range: 100H ~ 417H

Settings: See P0-09 for explanation.

Chapter 7 Servo Parameters | ASDA-A&A+ Series

P0 - 13	MAP4	Block Data Read / Write Register 4	Communication Addr.: 000DH
----------------	-------------	---	-----------------------------------

Default: 111H

Related Section: N/A

Applicable Control Mode: ALL

Unit: N/A

Range: 100H ~ 417H

Settings: See P0-09 for explanation.

P0 - 14	MAP5	Block Data Read / Write Register 5	Communication Addr.: 000EH
----------------	-------------	---	-----------------------------------

Default: 112H

Related Section: N/A

Applicable Control Mode: ALL

Unit: N/A

Range: 100H ~ 417H

Settings: See P0-09 for explanation.

P0 - 15	MAP6	Block Data Read / Write Register 6	Communication Addr.: 000FH
----------------	-------------	---	-----------------------------------

Default: 225H

Related Section: N/A

Applicable Control Mode: ALL

Unit: N/A

Range: 100H ~ 417H

Settings: See P0-09 for explanation.

P0 - 16	MAP7	Block Data Read / Write Register 7	Communication Addr.: 0010H
----------------	-------------	---	-----------------------------------

Default: 109H

Related Section: N/A

Applicable Control Mode: ALL

Unit: N/A

Range: 100H ~ 417H

Settings: See P0-09 for explanation.

P0 - 17	SVSTS	Servo Output Status Display	Communication Addr.: 0011H
----------------	--------------	------------------------------------	-----------------------------------

Default: N/A

Related Section:

Applicable Control Mode: ALL

Table 7.B

Unit: N/A

Range: N/A

Settings:

This parameter is used to display the digital output signal of the servo drive. The servo output status display will show in hexadecimal format.

Chapter 7 Servo Parameters | ASDA-A&A+ Series

Bit0: SRDY (Servo ready)

Bit1: SON (Servo On)

Bit2: ZSPD (At Zero speed)

Bit3: TSPD (At Speed reached)

Bit4: TPOS (At Positioning completed)

Bit5: TQL (At Torque limit)

Bit6: Reserved

Bit7: Reserved

Bit8: OLW (Output overload warning)

Bit9: WARN (Servo warning activated)

Bit10: CMDOK (Internal position command completed)

Bit11: Reserved

Bit12: Reserved

Bit13: ALRM (Servo alarm activated)

Bit14: BRKR (Electromagnetic brake control)

Bit15: HOME (Homing completed)

The servo output status display can be monitored through communication also.

Chapter 7 Servo Parameters | ASDA-A&A+ Series

Group 1: P1-xx Basic Parameters

P1 - 00▲	PTT	External Pulse Input Type	Communication Addr.: 0100H
-----------------	------------	----------------------------------	-----------------------------------

Default: 2

Related Section:

Applicable Control Mode: Pt

Section 6.2.1

Unit: N/A

Range: 00 ~ 132 (ASDA-A series)

00 ~ 1132 (ASDA-A+ series)

Settings:

ASDA-A series:

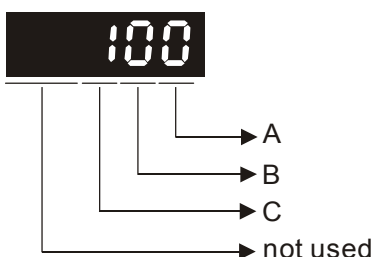

- A: Pulse type
 A=0: AB phase pulse (4x)
 A=1: CW + CCW pulse
 A=2: Pulse + Direction
 Other setting: Reversed

ASDA-A+ series:

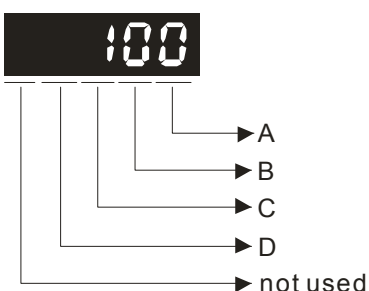

- B: Input pulse filter
 B=0: 500Kpps
 B=1: 200Kpps
 B=2: 150Kpps
 B=3: 80Kpps

This setting is used to suppress or reduce the chatter caused by the noise, etc. However, if the instant input pulse filter frequency is over high, the frequency that exceeds the setting value will be regarded as noise and filtered.

- C: Logic type

Pulse Type	0=Positive Logic		1=Negative Logic	
	Forward	Reverse	Forward	Reverse
AB phase pulse				
CW + CCW pulse				
Pulse + Direction				

Input pulse interface	Max. input pulse frequency
Line driver	500Kpps
Open collector	200Kpps

Chapter 7 Servo Parameters | ASDA-A&A+ Series

- D: Source of pulse command

Setting value	Input pulse interface	Max. input pulse frequency	Remark
0	Line driver	500Kpps	CN1 Terminal Identification: PULSE, /PULSE, SIGN, /SIGN
	Open collector	200Kpps	
1	Line driver for high-speed pulse	4Mpps	CN1 Terminal Identification: HPULSE, /HPULSE, HSIGN, /HSIGN

 **NOTE**

- 1) High-speed pulse function (max. input pulse frequency 4Mpps) is for ASDA-A+ only.

P1 - 01	CTL	Control Mode and Output Direction	Communication Addr.: 0101H
----------------	------------	--	-----------------------------------

Default: 00

Applicable Control Mode: ALL

Unit: pulse (P mode), r/min (S mode), N-m (T mode)

Range: 0 ~ 1110

Settings:

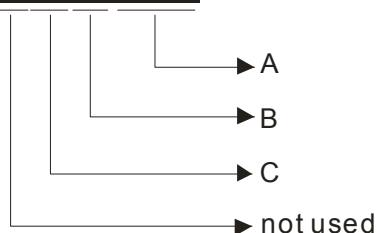

- A: Control mode settings
- B: Torque output direction settings

Control mode settings:

	Pt	Pr	S	T	Sz	Tz
00	▲					
01		▲				
02			▲			
03				▲		
04					▲	
05						▲
06	▲		▲			
07	▲			▲		
08		▲	▲			
09		▲		▲		
10			▲	▲		

Torque output direction settings:

	0	1
Forward		
Reverse		

Chapter 7 Servo Parameters | ASDA-A&A+ Series

- C=1: When switching to different mode, DIO (P2-10 ~ P2-22) can be reset to be the default value of the mode you switch to.
C=0: When switching to different mode, the setting value of DIO (P2-10 ~ P2-22) will remain the same and will not be changed.

P1 - 02▲	PSTL	Speed and Torque Limit	Communication Addr.: 0102H
-----------------	-------------	-------------------------------	-----------------------------------

Default: 00

Related Section:

Applicable Control Mode: ALL

Section 6.6

Unit: N/A

Range: 0 ~ 11

Settings:

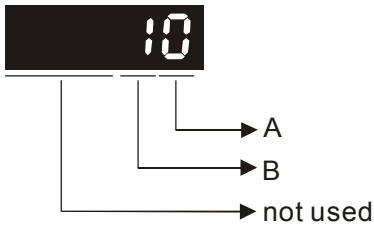

- A=0: Disable speed limit function
A=1: Enable speed limit function (It is available in torque mode)

Other: Reserved

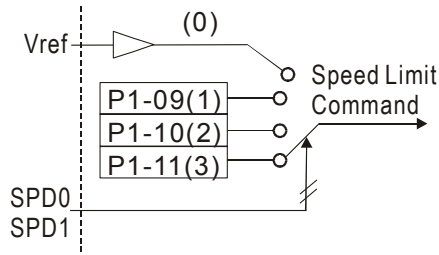

- B=0: Disable torque limit function
B=1: Enable torque limit function (It is available in position and speed mode)

Other: Reserved

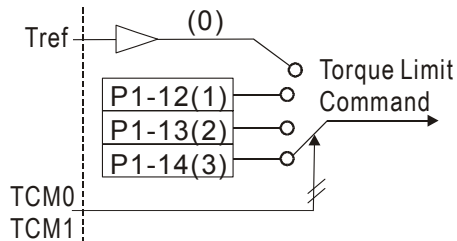

Chapter 7 Servo Parameters | ASDA-A&A+ Series

P1 - 03	AOUT	Pulse Output Polarity Setting	Communication Addr.: 0103H
----------------	-------------	--------------------------------------	-----------------------------------

Default: 0

Related Section:

Applicable Control Mode: ALL

Section 3.3.3

Unit: N/A

Range: 0 ~ 1

Settings:

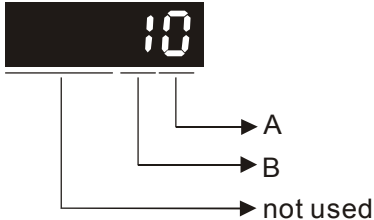

A: Monitor analog output polarity

B: Position pulse output polarity

A=0: MON1(+), MON2(+)

B=0: Forward output

A=1: MON1(+), MON2(-)

B=1: Reverse output

A=2: MON1(-), MON2(+)

A=3: MON1(-), MON2(-)

P1 - 04	MON1	Analog Monitor Output Proportion 1 (CH1)	Communication Addr.: 0104H
----------------	-------------	---	-----------------------------------

Default: 100

Related Section:

Applicable Control Mode: ALL

Section 6.4.4

Unit: % (full scale)

Range: 0 ~ 100

P1 - 05	MON2	Analog Monitor Output Proportion 2 (CH2)	Communication Addr.: 0105H
----------------	-------------	---	-----------------------------------

Default: 100

Related Section:

Applicable Control Mode: ALL

Section 6.4.4

Unit: % (full scale)

Range: 0 ~ 100

P1 - 06	SFLT	Accel / Decel Smooth Constant of Analog Speed Command (Low-pass Filter)	Communication Addr.: 0106H
----------------	-------------	--	-----------------------------------

Default: 0

Related Section:

Applicable Control Mode: S

Section 6.3.3

Unit: ms

Range: 0 ~ 1000 (0: Disabled)

Chapter 7 Servo Parameters | ASDA-A&A+ Series

P1 - 07	TFLT	Smooth Constant of Analog Torque Command (Low-pass Filter)	Communication Addr.: 0107H
----------------	-------------	---	-----------------------------------

Default: 0

Related Section:

Applicable Control Mode: T

Section 6.4.3

Unit: ms

Range: 0 ~ 1000 (0: Disabled)

P1 - 08	PFLT	Smooth Constant of Position Command (Low-pass Filter)	Communication Addr.: 0108H
----------------	-------------	--	-----------------------------------

Default: 0

Related Section:

Applicable Control Mode: Pt

Section 6.2.6

Unit: 10ms

Range: 0 ~ 1000 (0: Disabled)

P1 - 09	SP1	1st Speed Command or Limit	Communication Addr.: 0109H
----------------	------------	-----------------------------------	-----------------------------------

Default: 100

Related Section:

Applicable Control Mode: S, T

Section 6.3.1

Unit: r/min

Range: -5000 ~ +5000

Settings:

1st Speed Command

In Speed mode, this parameter is used to set speed 1 of internal speed command. For the decimal place setting of internal speed command, please refer to P2-63.

1st Speed Limit

In Torque mode, this parameter is used to set speed limit 1 of internal speed command.

P1 - 10	SP2	2nd Speed Command or Limit	Communication Addr.: 010AH
----------------	------------	-----------------------------------	-----------------------------------

Default: 200

Related Section:

Applicable Control Mode: S, T

Section 6.3.1

Unit: r/min

Range: -5000 ~ +5000

Settings:

2nd Speed Command

In Speed mode, this parameter is used to set speed 2 of internal speed command. For the decimal place setting of internal speed command, please refer to P2-63.

2nd Speed Limit

In Torque mode, this parameter is used to set speed limit 2 of internal speed command.

Chapter 7 Servo Parameters | ASDA-A&A+ Series

P1 - 11	SP3	3rd Speed Command or Limit	Communication Addr.: 010BH
----------------	------------	-----------------------------------	-----------------------------------

Default: 300

Related Section:

Applicable Control Mode: S, T

Section 6.3.1

Unit: r/min

Range: -5000 ~ +5000

Settings:

3rd Speed Command

In Speed mode, this parameter is used to set speed 3 of internal speed command. For the decimal place setting of internal speed command, please refer to P2-63.

3rd Speed Limit

In Torque mode, this parameter is used to set speed limit 3 of internal speed command.

P1 - 12	TQ1	1st Torque Command or Limit	Communication Addr.: 010CH
----------------	------------	------------------------------------	-----------------------------------

Default: 100

Related Section:

Applicable Control Mode: T, P/S

Section 6.4.1

Unit: %

Range: -300 ~ +300

Settings:

1st Torque Command

In Torque mode, this parameter is used to set torque 1 of internal torque command.

1st Torque Limit

In Position and Speed mode, this parameter is used to set torque limit 1 of internal torque command.

Digital output signal TQL is activated when the drive has detected that the motor has reached the torques limits set by either the parameters P1-12 ~ P1-14 of via an external analog voltage.

P1 - 13	TQ2	2nd Torque Command or Limit	Communication Addr.: 010DH
----------------	------------	------------------------------------	-----------------------------------

Default: 100

Related Section:

Applicable Control Mode: T, P/S

Section 6.4.1

Unit: %

Range: -300 ~ +300

Settings:

2nd Torque Command

In Torque mode, this parameter is used to set torque 2 of internal torque command.

Chapter 7 Servo Parameters | ASDA-A&A+ Series**2nd Torque Limit**

In Position and Speed mode, this parameter is used to set torque limit 2 of internal torque command.

Digital output signal TQL is activated when the drive has detected that the motor has reached the torques limits set by either the parameters P1-12 ~ P1-14 of via an external analog voltage.

P1 - 14	TQ3	3rd Torque Command or Limit	Communication Addr.: 010EH
----------------	------------	------------------------------------	-----------------------------------

Default: 100

Related Section:

Applicable Control Mode: T, P/S

Section 6.4.1

Unit: %

Range: -300 ~ +300

Settings:

3rd Speed Command

In Torque mode, this parameter is used to set torque 3 of internal torque command.

3rd Speed Limit

In Position and Speed mode, this parameter is used to set torque limit 3 of internal torque command.

Digital output signal TQL is activated when the drive has detected that the motor has reached the torques limits set by either the parameters P1-12 ~ P1-14 of via an external analog voltage.

P1 - 15	PO1H	1st Position Command for Rotation	Communication Addr.: 010FH
----------------	-------------	--	-----------------------------------

Default: 0

Related Section:

Applicable Control Mode: Pr

Section 6.2.2

Unit: rev

Range: -30000 ~ +30000

Settings:

This parameter is used to set rotation cycle number of internal position 1.

P1 - 16	PO1L	1st Position Command for Pulse	Communication Addr.: 0110H
----------------	-------------	---------------------------------------	-----------------------------------

Default: 0

Related Section:

Applicable Control Mode: Pr

Section 6.2.2

Unit: pulse

Range: +/-max. cnt/rev

Settings:

This parameter is used to set rotation pulse number of internal position 1.

Stroke1 = PO1H × (cnt/rev) + PO1L

Chapter 7 Servo Parameters | ASDA-A&A+ Series

P1 - 17	PO2H	2nd Position Command for Rotation	Communication Addr.: 0111H
Default: 0		Related Section:	
Applicable Control Mode: Pr		Section 6.2.2	
Unit: rev			
Range: -30000 ~ +30000			
Settings:			
This parameter is used to set rotation cycle number of internal position 2.			

P1 - 18	PO2L	2nd Position Command for Pulse	Communication Addr.: 0112H
Default: 0		Related Section:	
Applicable Control Mode: Pr		Section 6.2.2	
Unit: pulse			
Range: +/-max. cnt/rev			
Settings:			
This parameter is used to set rotation pulse number of internal position 2.			
Stroke2 = PO2H × (cnt/rev) + PO2L			

P1 - 19	PO3H	3rd Position Command for Rotation	Communication Addr.: 0113H
Default: 0		Related Section:	
Applicable Control Mode: Pr		Section 6.2.2	
Unit: rev			
Range: -30000 ~ +30000			
Settings:			
This parameter is used to set rotation cycle number of internal position 3.			

P1 - 20	PO3L	3rd Position Command for Pulse	Communication Addr.: 0114H
Default: 0		Related Section:	
Applicable Control Mode: Pr		Section 6.2.2	
Unit: pulse			
Range: +/-max. cnt/rev			
Settings:			
This parameter is used to set rotation pulse number of internal position 3.			
Stroke3 = PO3H × (cnt/rev) + PO3L			

Chapter 7 Servo Parameters | ASDA-A&A+ Series

P1 - 21	PO4H	4th Position Command for Rotation	Communication Addr.: 0115H
Default: 0		Related Section:	
Applicable Control Mode: Pr		Section 6.2.2	
Unit: rev			
Range: -30000 ~ +30000			
Settings:			
This parameter is used to set rotation cycle number of internal position 4.			

P1 - 22	PO4L	4th Position Command for Pulse	Communication Addr.: 0116H
Default: 0		Related Section:	
Applicable Control Mode: Pr		Section 6.2.2	
Unit: pulse			
Range: +/-max. cnt/rev			
Settings:			
This parameter is used to set rotation pulse number of internal position 4.			
Stroke4 = PO4H × (cnt/rev) + PO4L			

P1 - 23	PO5H	5th Position Command for Rotation	Communication Addr.: 0117H
Default: 0		Related Section:	
Applicable Control Mode: Pr		Section 6.2.2	
Unit: rev			
Range: -30000 ~ +30000			
Settings:			
This parameter is used to set rotation cycle number of internal position 5.			

P1 - 24	PO5L	5th Position Command for Pulse	Communication Addr.: 0118H
Default: 0		Related Section:	
Applicable Control Mode: Pr		Section 6.2.2	
Unit: pulse			
Range: +/-max. cnt/rev			
Settings:			
This parameter is used to set rotation pulse number of internal position 5.			
Stroke5 = PO5H × (cnt/rev) + PO5L			

Chapter 7 Servo Parameters | ASDA-A&A+ Series

P1 - 25	PO6H	6th Position Command for Rotation	Communication Addr.: 0119H
Default: 0		Related Section:	
Applicable Control Mode: Pr		Section 6.2.2	
Unit: rev			
Range: -30000 ~ +30000			
Settings:			
This parameter is used to set rotation cycle number of internal position 6.			

P1 - 26	PO6L	6th Position Command for Pulse	Communication Addr.: 011AH
Default: 0		Related Section:	
Applicable Control Mode: Pr		Section 6.2.2	
Unit: pulse			
Range: +/-max. cnt/rev			
Settings:			
This parameter is used to set rotation pulse number of internal position 6.			
Stroke6 = PO6H × (cnt/rev) + PO6L			

P1 - 27	PO7H	7th Position Command for Rotation	Communication Addr.: 011BH
Default: 0		Related Section:	
Applicable Control Mode: Pr		Section 6.2.2	
Unit: rev			
Range: -30000 ~ +30000			
Settings:			
This parameter is used to set rotation cycle number of internal position 7.			

P1 - 28	PO7L	7th Position Command for Pulse	Communication Addr.: 011CH
Default: 0		Related Section:	
Applicable Control Mode: Pr		Section 6.2.2	
Unit: pulse			
Range: +/-max. cnt/rev			
Settings:			
This parameter is used to set rotation pulse number of internal position 7.			
Stroke7 = PO7H × (cnt/rev) + PO7L			

Chapter 7 Servo Parameters | ASDA-A&A+ Series

P1 - 29**PO8H****8th Position Command for Rotation****Communication Addr.: 011DH**

Default: 0

Related Section:

Applicable Control Mode: Pr

Section 6.2.2

Unit: rev

Range: -30000 ~ +30000

Settings:

This parameter is used to set rotation cycle number of internal position 8.

P1 - 30**PO8L****8th Position Command for Pulse****Communication Addr.: 011EH**

Default: 0

Related Section:

Applicable Control Mode: Pr

Section 6.2.2

Unit: pulse

Range: +/-max. cnt/rev

Settings:

This parameter is used to set rotation pulse number of internal position 8.

Stroke8 = PO8H × (cnt/rev) + PO8L

P1 - 31**Reserved****P1 - 32****LSTP****Motor Stop Mode Selection****Communication Addr.: 0120H**

Default: 0

Related Section: N/A

Applicable Control Mode: ALL

Unit: N/A

Range: 0 ~ 11

Settings:

This parameter is used to select servo motor stop mode.

When a fault (servo alarm) occurs (except for CWL, CCWL, EMGS and serial communication error), it is used to set servo motor stop mode.

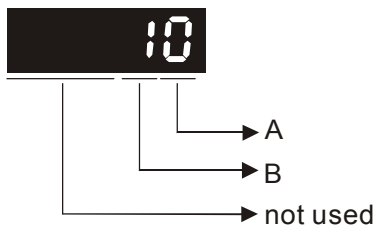

- A=0: Stop instantly
- A=1: Decelerate to stop
- B=0: Use dynamic brake when Servo Off (when the servo drive is Off).
- B=1: Allow servo motor to coast to stop when Servo Off (when the servo drive is Off).

Chapter 7 Servo Parameters | ASDA-A&A+ Series

P1 - 33	POSS	Position Control Mode (Pr)	Communication Addr.: 0121H
	Default: 0		Related Section:
	Applicable Control Mode: Pr		Section 6.2.2
	Unit: N/A		
	Range: 0 ~ 6		
	Settings:		
	This parameter determines the specific type of position control for Pr mode with the internal INDEX number. (Please refer to Chapter 6 and Chapter 12 for explanation and examples.)		
	0: Absolute positioning mode		
	1: Incremental positioning mode		
	2: Forward operation feed step mode		
	3: Reverse operation feed step mode		
	4: Shortest path feed step mode		
	5: Continuous auto-running positioning mode (Absolute)		
	6: Continuous auto-running positioning mode (Incremental)		
	7: One-cycle auto-running positioning mode (Absolute)		
	8: One-cycle auto-running positioning mode (Incremental)		
	This function when changed from absolute to incremental or incremental to absolute only gets registered in the drive after switching power off and on.		

P1 - 34	TACC	Acceleration Time	Communication Addr.: 0122H
	Default: 200		Related Section:
	Applicable Control Mode: Pr, S		P1-35, P1-36, Section 6.3.3
	Unit: ms		
	Range: 1 ~ 20000		
	Settings:		
	1st to 3rd step acceleration time.		
	It is used to determine the acceleration time to accelerate from 0 to its rated motor speed. (When P1-36 is set to 0: Accel/Decel function is disabled, i.e. P1-34, P1-35 is disabled.)		

P1 - 35	TDEC	Deceleration Time	Communication Addr.: 0123H
	Default: 200		Related Section:
	Applicable Control Mode: Pr, S		P1-34, P1-36, Section 6.3.3
	Unit: ms		
	Range: 1 ~ 20000		
	Settings:		
	1st to 3rd step deceleration time.		

Chapter 7 Servo Parameters | ASDA-A&A+ Series

It is used to determine the deceleration time to decelerate from its rated motor speed to 0.
(When P1-36 is set to 0: Accel/Decel function is disabled, i.e. P1-34, P1-35 is disabled.)

P1 - 36	TSL	Accel /Decel S-curve	Communication Addr.: 0124H
----------------	------------	-----------------------------	-----------------------------------

Pr mode Default: 20 (See Note 2)

Other mode Default: 0

Unit: ms

Range: 0 ~ 10000 (0: Disabled)

Settings:

This parameter is used to make the motor run more smoothly when startup and windup.

Using this parameter can improve the motor running stability.

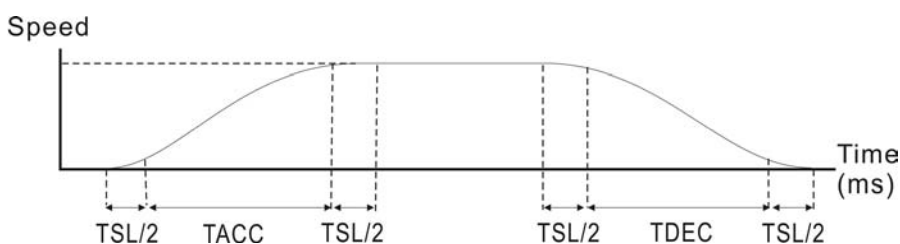

TSL: P1-36, Accel /Decel S-curve

TACC: P1-34, Acceleration time

TDEC: P1-35, Deceleration time

Total acceleration time = TACC + TSL

Total deceleration time = TDEC + TSL

NOTE

- 1) If the control of the servo motor is achieved via internal parameters, the command curve should be defined by the users. Therefore, when the command source is internal parameter, ensure that the setting value of P1-36 is not set to 0 or the servo motor will not accelerate or decelerate during operation.
- 2) So if users change the control mode to Pr mode and switching power off and on, the servo drive of parameter P1-36 will auto set the value to 20.

P1 - 37	GDR	Ratio of Load Inertia to Servo Motor Inertia	Communication Addr.: 0125H
----------------	------------	---	-----------------------------------

Default: 5.0 (ASDA-A series) or 0.00 (ASDA-A+ series)

Applicable Control Mode: ALL

Unit: times

Range: 0 ~ 200.0

Settings:

Ratio of load inertia to servo motor inertia: (J_load /J_motor)

Related Section:

Section 6.3.6

Chapter 7 Servo Parameters | ASDA-A&A+ Series

P1 - 38	ZSPD	Zero Speed Range Setting	Communication Addr.: 0126H
----------------	-------------	---------------------------------	-----------------------------------

Default: 10

Related Section: N/A

Applicable Control Mode: ALL

Unit: r/min

Range: 0 ~ 200

Settings:

This parameter is used to set output range of zero speed signal (ZSPD).

ZSPD is activated when the drive senses the motor is equal to or below the Zero Speed Range setting as defined in parameter P1-38.

For Example, at default ZSPD will be activated when the drive detects the motor rotating at speed at or below 10 r/min. ZSPD will remain activated until the motor speed increases above 10 r/min.

P1 - 39	SSPD	Target Motor Speed	Communication Addr.: 0127H
----------------	-------------	---------------------------	-----------------------------------

Default: 3000

Related Section: N/A

Applicable Control Mode: ALL

Unit: r/min

Range: 0 ~ 5000

Settings:

When target motor speed reaches its preset value, digital output (TSPD) is enabled. When the forward and reverse speed of servo motor is equal and higher than the setting value, the motor will reach the target motor speed, and then TSPD signal will output.

TSPD is activated once the drive has detected the motor has reached the Target Motor Speed setting as defined in parameter P1-39. TSPD will remain activated until the motor speed drops below the Target Motor Speed.

P1 - 40▲	VCM	Max. Analog Speed Command or Limit	Communication Addr.: 0128H
-----------------	------------	---	-----------------------------------

Default: rated speed

Related Section:

Applicable Control Mode: S/T

Section 6.3.4, P1-55

Unit: r/min

Range: 0 ~ 10000

Settings:

In **Speed mode**, this parameter is used to set the speed at the maximum input voltage (10V) of the analog speed command.

In **Torque mode**, this parameter is used to set the speed at the maximum input voltage (10V) of the analog speed limit.

Chapter 7 Servo Parameters | ASDA-A&A+ Series

For example, in speed mode, if P1-40 is set to 3000 and the input voltage is 10V, it indicates that the speed command is 3000 r/min. If P1-40 is set to 3000, but the input voltage is changed to 5V, then the speed command is changed to 1500 r/min.

$$\text{Speed command / limit} = \text{Input voltage} \times \text{setting}/10$$

P1 - 41▲	TCM	Max. Analog Torque Command or Limit	Communication Addr.: 0129H
-----------------	------------	--	-----------------------------------

Default: 100

Related Section:

Applicable Control Mode: ALL

Section 6.4.4

Unit: %

Range: 0 ~ 1000

Settings:

In **Torque mode**, this parameter is used to set the output torque at maximum input voltage (10V) of analog torque command.

In **Position** and **Speed mode**, this parameter is used to set output torque at maximum input voltage (10V) of analog torque limit

For example, in torque mode, if P1-41 is set to 100 and the input voltage is 10V, it indicates that the torque command is 100% rated torque. If P1-41 is set to 100, but the input voltage is changed to 5V, then the torque command is changed to 50% rated torque.

$$\text{Torque command / limit} = \text{Input voltage} \times \text{setting}/10 (\%)$$

P1 - 42	MBT1	On Delay Time of Electromagnetic Brake	Communication Addr.: 012AH
----------------	-------------	---	-----------------------------------

Default: 0

Related Section:

Applicable Control Mode: ALL

P1-43, Section 6.5.5

Unit: ms

BRKR(08) in Table 7.B

Range: 0 ~ 1000

Settings:

Used to set the period of time between when the servo drive is On (Servo On) and when electromagnetic brake output signal (BRKR) is activated.

P1 - 43	MBT2	OFF Delay Time of Electromagnetic Brake	Communication Addr.: 012BH
----------------	-------------	--	-----------------------------------

Default: 0

Related Section:

Applicable Control Mode: ALL

P1-43, Section 6.5.5

Unit: ms

BRKR(08) in Table 7.B

Range: 0 ~ 1000

Settings:

Used to set the period of time between when the servo drive is Off (Servo Off) and when electromagnetic brake output signal (BRKR) is inactivated.

Chapter 7 Servo Parameters | ASDA-A&A+ Series

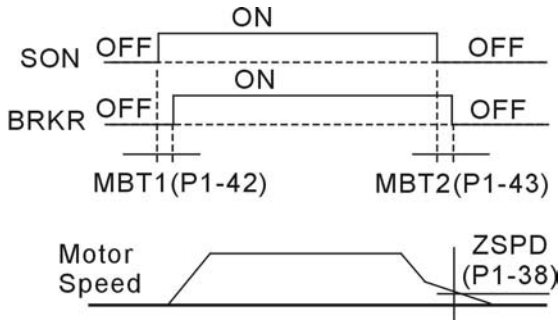

NOTE

- 1) When MBT2 delay time has not finished and motor speed is lower than the setting value of P1-38, electromagnetic brake interlock signal (BRKR) is closed.
- 2) When MBT2 delay time has finished and motor speed is still higher than the setting value of P1-38, electromagnetic brake interlock signal (BRKR) is closed.

P1 - 44▲	GR1	Electronic Gear Ratio (1st Numerator) (N1)	Communication Addr.: 012CH
-----------------	------------	---	-----------------------------------

Default: 1

Related Section:

Applicable Control Mode: Pt, Pr

Section 6.2.5

Unit: pulse

Range: 1 ~ 32767

Settings:

Multiple-step electronic gear numerator setting. Please refer to P2-60~P2-62.

P1 - 45▲	GR2	Electronic Gear Ratio (Denominator)	Communication Addr.: 012DH
-----------------	------------	--	-----------------------------------

Default: 1

Related Section:

Applicable Control Mode: Pt, Pr

Section 6.2.5

Unit: pulse

Range: 1 ~ 32767

Settings:

Electronic gear denominator setting.

It is recommended to set electronic gear ratio when the servo drive is Off. As the wrong setting may cause motor to run chaotically (out of control) and it may lead to personnel injury, therefore, ensure to observe the following rule when setting P1-44, P1-45.

The electronic gear ratio setting (Please also see P1-44, P2-60 ~ P2-62):

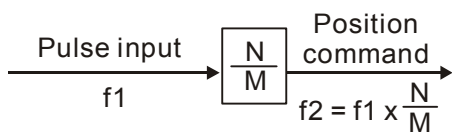

f1: Pulse input

f2: Position command

N: Numerator 1, 2, 3, 4, the setting value of P1-44 or P2-60 ~ P2-63

M: Denominator, the setting value of P1-45

The electronic gear ratio setting range must be within: $1/50 < N/M < 200$.

Chapter 7 Servo Parameters | ASDA-A&A+ Series

P1 - 46▲

GR3

Encoder Output Pulse Number

Communication Addr.: 012EH

Default: 1

Related Section: N/A

Applicable Control Mode: ALL

Unit: pulse

Range: 1 ~ 125 (with B=0)

10020 ~ 12500 (with B=1)

Settings:

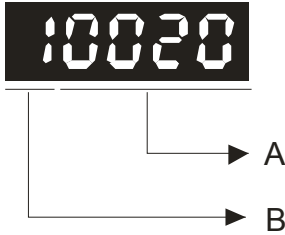

This parameter is used to set the pulse numbers of encoder outputs per motor revolution.

ASDA-A series:

A: Range of the pulse numbers or the pulse dividing ratio of the encoder outputs

- Range of the setting value: 1 ~ 125 (with B=0) or 20 ~ 2500 (with B=1)

B: Pulse dividing ratio function selection

- When B=0, the setting value A represents the pulse dividing ratio, which is equal to 2500/A. At this time, the range of the setting value A is 1 ~ 125.

For example:

If A=2 and B=0, i.e. P1-46 is set to 2, the pulse dividing ratio is equal to 2500/2 = 1250.

It indicates that the pulse numbers of encoder outputs per motor revolution = 1250 pulses
(The encoder will output 1250 pulses per motor revolution)

If A=5 and B=0, i.e. P1-46 is set to 5, the pulse dividing ratio is equal to 2500/5 = 500.

It indicates that the pulse numbers of encoder outputs per motor revolution = 500 pulses
(The encoder will output 500 pulses per motor revolution)

- When B=1, the setting value A directly represents the pulse numbers of encoder outputs per motor revolution. At this time, the range of the setting value A is 20 ~ 2500.

If A=1250 and B=1, i.e. P1-46 is set to 11250, the pulse numbers of encoder outputs per motor revolution = 1250 pulses (The encoder will output 1250 pulses per motor revolution)

If A=500 and B=1, i.e. P1-46 is set to 10500, the pulse numbers of encoder outputs per motor revolution = 500 pulses (The encoder will output 500 pulses per motor revolution)

ASDA-A+ series:

A: Range of the pulse numbers or the pulse dividing ratio of the encoder outputs

- Range of the setting value: 1 ~ 125 (with B=0) or 20 ~ 2500 (with B=1)

B: Pulse dividing ratio function selection

- When B=0, the range of the setting value A is 1 ~ 125, the pulse numbers of encoder outputs per motor revolution = $\frac{2500}{A} \times \frac{2^7}{2^{P1-61}}$ ($1 \leq A \leq 125$)

Chapter 7 Servo Parameters | ASDA-A&A+ Series

For example:

If A=2 and B=0, i.e. P1-46 is set to 2, and P1-61 is set to 7 (Default), the pulse numbers of

$$\text{encoder outputs per motor revolution} = \frac{2500}{2} \times \frac{2^7}{2^7} = 1250$$

It indicates that the encoder will output 1250 pulses per motor revolution.

- When B=1, the range of the setting value A is 20 ~ 2500, the pulse numbers of encoder

$$\text{outputs per motor revolution} = A \times \frac{2^7}{2^{P1-61}} \quad (1 \leq A \leq 2500)$$

If A=500 and B=1, i.e. P1-46 is set to 10500, and P1-61 is set to 7 (Default), the pulse

$$\text{numbers of encoder outputs per motor revolution} = (500) \times \frac{2^7}{2^7} = 500$$

It indicates that the encoder will output 500 pulses per motor revolution.

NOTE

- 1) The default setting of parameter P1-61 is 7.
- 2) The max. frequency for pulse output is 500Kpps.

P1 - 47

HMOV	Homing Mode	Communication Addr.: 012FH
-------------	--------------------	-----------------------------------

Default: 00

Related Section:

Applicable Control Mode: ALL

Section 12.8

Unit: N/A

Range: 00 ~ 1225

Settings:

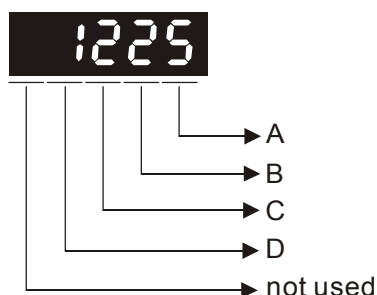

- A=0: Forward homing (CCWL as "Home")
- A=1: Reverse homing (CWL as "Home")
- A=2: Forward homing (ORGP as "Home")
- A=3: Reverse homing (ORGP as "Home")
- A=4: Forward to find Z-phase pulse and regard Z-phase pulse as "Home"
- A=5: Reverse to find Z-phase pulse and regard Z-phase pulse as "Home"
- B=0: Return to find Z-phase pulse during homing
- B=1: Do not return and go forward to find Z-phase pulse during homing
- B=2: Positioning at home sensor position or Z-phase pulse during homing (it only can be used when A=2, 3, 4 or 5)
- C=0: Disable homing function.
- C=1: Enable homing function automatically after power supplies to the servo drive.

Chapter 7 Servo Parameters | ASDA-A&A+ Series

- C=2: Enable homing function by SHOM.
- D=0: After detecting “Home”, the motor will decelerate and return to “Home”.
- D=1: After detecting “Home”, the motor will decelerate and stop in the forward direction.
- Other: Reserved

Example:

Power supplies to the servo drive, after servo on, activate SHOM signal. Then, immediately perform the homing function and use ORGP as “Home”.

1: Refer to P1-01 for forward and reverse direction

2: To avoid that errors may occur, please perform the settings for CWL and CCWL and enable the function of SHOM first (refer to Table 7.A and P2-10 ~ P2-17). Then, use with the external limit switches and connect them to the corresponding input contact. If the settings are incorrect or there is no corresponding external limit switch, the drive and motor may not work normally.

3: Set the value of P1-47 to 203.

4: Use external signal to enable the function of SHOM. Then, the drive will command the motor to move to “Home”. When ORGP (reference “Home” sensor) is searched, the motor will return in 2nd speed setting, and reverse to find the nearest Z-phase pulse and regard it as “Home”.

P1 - 48

HSPD1	1st Speed Setting of High Speed Homing	Communication Addr.: 0130H
--------------	---	-----------------------------------

Default: 1000

Applicable Control Mode: ALL

Unit: r/min

Range: 1 ~ 2000

Settings:

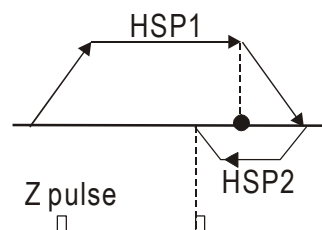

Related Section:

Section 12.8

P1 - 49

HSPD2	2nd Speed Setting of Low Speed Homing	Communication Addr.: 0131H
--------------	--	-----------------------------------

Default: 50

Applicable Control Mode: ALL

Unit: r/min

Range: 1 ~ 500

Settings:

Please refer to P1-48.

Related Section:

Section 12.8

Chapter 7 Servo Parameters | ASDA-A&A+ Series

P1 - 50	HOF1	Homing Offset Rotation Number	Communication Addr.: 0132H
Default: 0		Related Section:	
Applicable Control Mode: ALL		Section 12.8	
Unit: rev			
Range: -30000 ~ +30000			
Settings:			
Please refer to P1-51.			

P1 - 51	HOF2	Homing Offset Pulse Number	Communication Addr.: 0133H
Default: 0		Related Section:	
Applicable Control Mode: ALL		Section 12.8	
Unit: pulse			
Range: +/-max. cnt/rev			
Settings:			
When the value of HOF1, HOF2 (P1-50, P1-51) is set to 0, "Home" will be determined as Z-phase pulse or ORGP according to the setting of P1-47. If the value of HOF1, HOF2 (P1-50, P1-51) is not 0, "Home" will be determined as Z-phase pulse or ORGP plus one offset pulse as new "Home" (HOF1 x 10000 + HOF2).			

P1 - 52	RES1	Regenerative Resistor Value	Communication Addr.: 0134H
Default: -		Related Section:	
Applicable Control Mode: ALL		Section 6.6.3	
Unit: Ohm			
Range: 10 ~ 750 (ASDA-A series)			
5 ~ 750 (ASDA-A+ series)			
Settings:			
ASDA-A series			
Model		Default	
1.5kW and below		40	
above 1.5kW		20	
ASDA-A+ series			
Model		Default	
4.5kW		20	
5.5kW and above		15	

Chapter 7 Servo Parameters | ASDA-A&A+ Series

P1 - 53

RES2	Regenerative Resistor Capacity	Communication Addr.: 0135H
-------------	---------------------------------------	-----------------------------------

Default: -

Related Section:

Applicable Control Mode: ALL

Section 6.6.3

Unit: Watt

Range: 30 ~ 1000 (ASDA-A series)

0 ~ power of the drive (ASDA-A+ series)

Settings:

ASDA-A series

Model	Default
1.5kW and below	60
above 1.5kW	120

ASDA-A+ series

Model	Default
4.5kW	100
5.5kW and above	0

P1 - 54

PER	Positioning Completed Width	Communication Addr.: 0136H
------------	------------------------------------	-----------------------------------

Default: 100

Related Section: N/A

Applicable Control Mode: Pt , Pr

Unit: pulse (ASDA-A series, Pr mode of ASDA-A+ series)

1/10000 rev. (Pt mode of ASDA-A+ series)

Range: 0 ~ 10000

Settings:

In Pt mode, when the error pulse numbers is less than the setting value of parameter P1-54, TPOS (At positioning completed signal) will be activated.

In Pr mode, when the difference in pulse number between the target position and the actual position is less than the setting value of parameter P1-54, TPOS (At positioning completed signal) will be activated.

P1 - 55

MSPD	Maximum Speed Limit	Communication Addr.: 0137H
-------------	----------------------------	-----------------------------------

Default: rated speed

Related Section: N/A

Applicable Control Mode: ALL

Unit: r/min

Range: 0 ~ Max. speed

Settings:

This parameter is used to set maximum motor speed. The default setting is rated speed.

Chapter 7 Servo Parameters | ASDA-A&A+ Series

P1 - 56	OVW	Output Overload Warning Time	Communication Addr.: 0138H
----------------	------------	-------------------------------------	-----------------------------------

Default: 120

Related Section: N/A

Applicable Control Mode: ALL

Unit: %

Range: 0 ~ 120

Settings:

This parameter is used to set output overload time.

If the setting value of parameter P1-56 is set to 0 ~ 100, the function of parameter P1-56 is enabled. When the motor has reached the output overload time set by parameter P1-56, the motor will send a warning to the drive. After the drive has detected the warning, the DO signal OLW will be activated.

If the setting value of parameter P1-56 exceeds 100, the function of parameter P1-56 is disabled.

t_{OL} = Permissible Time for Overload x the setting value of parameter P1-56

When overload accumulated time (continuously overload time) exceeds the value of **t_{OL}**, the overload warning signal will output, i.e. DO signal, OLW will be ON. However, if the accumulated overload time (continuous overload time) exceeds the permissible time for overload, the overload alarm (ALE06) will occur.

For example:

If the setting value of parameter P1-56 (Output Overload Warning Time) is 60%, when the permissible time for overload exceeds 8 seconds at 200% rated output, the overload fault (ALE06) will be detected and shown on the LED display.

At this time, **t_{OL}** = 8 x 60% = 4.8 seconds

Result:

When the drive output is at 200% rated output and the drive is continuously overloaded for 4.8 seconds, the overload warning signal will be ON (DO code is 10, i.e. DO signal OLW will be activated) and the overload warning (ALE23) will be displayed. If the drive is continuously overloaded for 8 seconds, the overload alarm will be detected and shown on the LED display (ALE06). Then, Servo Fault signal will be ON (DO signal ALRM will be activated).

P1 - 57	Reserved	Communication Addr.: 0139H
----------------	-----------------	-----------------------------------

P1 - 58	Reserved	Communication Addr.: 013AH
----------------	-----------------	-----------------------------------

Chapter 7 Servo Parameters | ASDA-A&A+ Series

P1 - 59**MFLT****Analog Speed Linear Filter****Communication Addr.: 013BH**

Default: 0

Related Section: N/A

Applicable Control Mode: S

Unit: 0.1ms

Range: 0 ~ 40

Settings:

This function is for ASDA-A+ series only. This parameter is used to eliminate the noise generated during the operation when the host (external) controller sends the step analog voltage speed command. If the setting value of parameter P1-59 is set to the step holding time, it can facilitate the smooth operation of the motor very effectively.

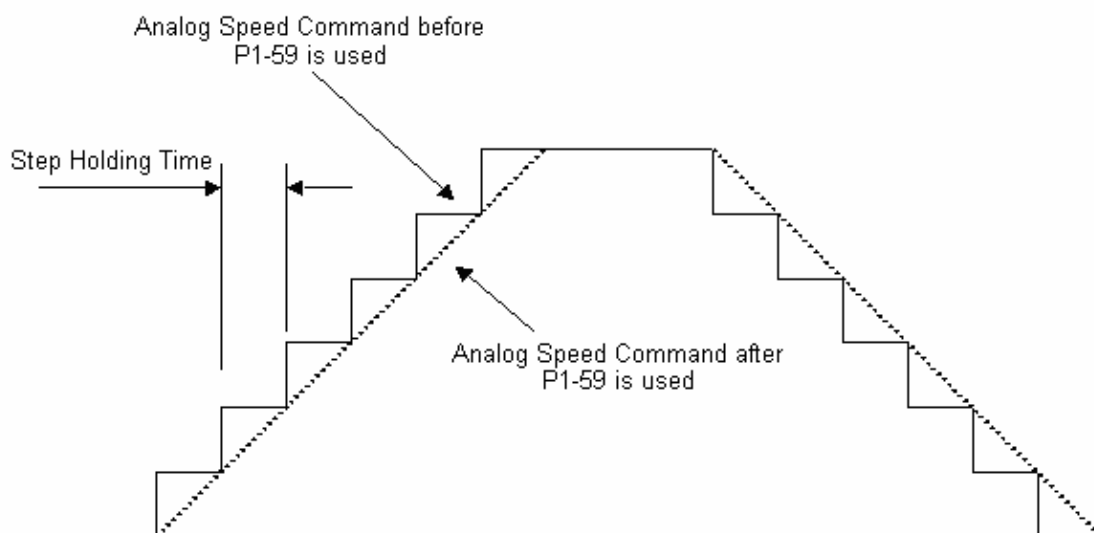
**P1 - 60****GR7****High Resolution Electronic Gear Ratio****Communication Addr.: 013CH**

Default: 7

Related Section: N/A

Applicable Control Mode: Pt

Unit: -

Range: 0 ~ 7

Settings:

This function is for ASDA-A+ series only. For the models which encoder resolution is 1280000 pulses per motor revolution, using this parameter can enhance the resolution for positioning. The default setting of this parameter is 7. When the ratio of Electronic Gear Numerator to Electronic Gear Denominator is equal to 1 (1:1), each pulse command corresponds to 1/10000 rev. per motor revolution. When P1-60 is set to 0 and the ratio of Electronic Gear Numerator to Electronic Gear Denominator is also equal to 1 (1:1), each pulse command corresponds to 1/1280000 rev. per motor revolution.

Chapter 7 Servo Parameters | ASDA-A&A+ Series

P1 - 61	GR8	High Resolution Output Pulse Number	Communication Addr.: 013DH
----------------	------------	--	-----------------------------------

Default: 7

Related Section: N/A

Applicable Control Mode: Pt

Unit: -

Range: 0 ~ 7

Settings:

This function is for ASDA-A+ series only. Please refer to P1-46 for explanation.

P1 - 62	COKT	Delay Time of Internal Position Command Completed Output Signal	Communication Addr.: 013EH
----------------	-------------	--	-----------------------------------

Default: 0

Related Section:

Applicable Control Mode: Pr

DO CMDOK(12) in Table 7.B

Unit: ms

Range: 0 ~ 200

Settings:

This parameter is used to delay the output time of digital output, CMDOK (Internal position command completed output) when the servo drive has detected the internal position command has been completed.

If this parameter is set to 0, when DO ZSPD=1, the internal position command which is triggered by DI CTRG will be accepted. If this parameter is not set to 0, when DO CMDOK=1, the internal position command which is triggered by DI CTRG will be accepted.

Please see DO CMDOK(12) in Table 7.B for explanation.

P1 - 63	Reserved	Communication Addr.: 013FH
----------------	-----------------	-----------------------------------

P1 - 64	Reserved	Communication Addr.: 0140H
----------------	-----------------	-----------------------------------

Chapter 7 Servo Parameters | ASDA-A&A+ Series

Group 2: P2-xx Extension Parameters

P2 - 00	KPP	Proportional Position Loop Gain	Communication Addr.: 0200H
----------------	------------	--	-----------------------------------

Default: 35

Related Section:

Applicable Control Mode: Pt, Pr

Section 6.2.8

Unit: rad/s

Range: 0 ~ 1023

Settings:

This parameter is used to set the position loop gain. It can increase stiffness, expedite position loop response and reduce position error. However, if the setting value is over high, it may generate vibration or noise.

P2 - 01	PPR	Position Loop Gain Switching Rate	Communication Addr.: 0201H
----------------	------------	--	-----------------------------------

Default: 100

Related Section: N/A

Applicable Control Mode: Pt, Pr

Unit: %

Range: 10 ~ 500

Settings:

This parameter is used to set the position gain switching rate when the gain switching condition is satisfied. Please refer to P2-27 for gain switching control selection settings and refer to P2-29 for gain switching condition settings.

P2 - 02	PFG	Position Feed Forward Gain	Communication Addr.: 0202H
----------------	------------	-----------------------------------	-----------------------------------

Default: 5000

Related Section:

Applicable Control Mode: Pt, Pr

Section 6.2.8

Unit: 0.0001

Range: 10 ~ 20000

Settings:

This parameter is used to set the feed forward gain when executing position control command. When using position smooth command, increase gain can improve position track deviation. When not using position smooth command, decrease gain can improve the resonance condition of mechanical system. However, if the setting value is over high, it may generate vibration or noise.

Chapter 7 Servo Parameters | ASDA-A&A+ Series

P2 - 03	PFF	Smooth Constant of Position Feed Forward Gain	Communication Addr.: 0203H
----------------	------------	--	-----------------------------------

Default: 5

Related Section: N/A

Applicable Control Mode: Pt, Pr

Unit: ms

Range: 2 ~ 100

Settings:

When using position smooth command, increase gain can improve position track deviation.

When not using position smooth command, decrease gain can improve the resonance condition of mechanical system.

P2 - 04	KVP	Proportional Speed Loop Gain	Communication Addr.: 0204H
----------------	------------	-------------------------------------	-----------------------------------

Default: 500

Related Section:

Applicable Control Mode: ALL

Section 6.3.6

Unit: rad/s

Range: 0 ~ 20000 (ASDA-A series)

0 ~ 4095 (ASDA-A+ series)

Settings:

This parameter is used to set the speed loop gain. When the value of proportional speed loop gain is increased, it can expedite speed loop response. However, if the setting value is over high, it may generate vibration or noise.

P2 - 05	SPR	Speed Loop Gain Switching Rate	Communication Addr.: 0205H
----------------	------------	---------------------------------------	-----------------------------------

Default: 100

Related Section: N/A

Applicable Control Mode: ALL

Unit: %

Range: 10 ~ 500

Settings:

This parameter is used to set the speed gain switching rate when the gain switching condition is satisfied. Please refer to P2-27 for gain switching control selection settings and refer to P2-29 for gain switching condition settings.

P2 - 06	KVI	Speed Integral Compensation	Communication Addr.: 0206H
----------------	------------	------------------------------------	-----------------------------------

Default: 100

Related Section:

Applicable Control Mode: ALL

Section 6.3.6

Unit: N/A

Range: 0 ~ 4095 (ASDA-A series)

0 ~ 1023 (ASDA-A+ series)

Chapter 7 Servo Parameters | ASDA-A&A+ Series

Settings:

This parameter is used to set the integral time of speed loop. When the value of speed integral compensation is increased, it can improve the speed response ability and decrease the speed control deviation. However, if the setting value is over high, it may generate vibration or noise.

P2 - 07	SFG	Speed Feed Forward Gain	Communication Addr.: 0207H
----------------	------------	--------------------------------	-----------------------------------

Default: 0

Related Section:

Applicable Control Mode: ALL

Section 6.3.6

Unit: 0.0001

Range: 0 ~ 20000

Settings:

This parameter is used to set the feed forward gain when executing speed control command.

When using speed smooth command, increase gain can improve speed track deviation.

When not using speed smooth command, decrease gain can improve the resonance condition of mechanical system.

P2 - 08	PCTL	Special Factory Setting	Communication Addr.: 0208H
----------------	-------------	--------------------------------	-----------------------------------

Default: 0

Related Section: N/A

Applicable Control Mode: ALL

Unit: N/A

Range: 0 ~ 65536

This parameter can be used to reset all parameters to their original factory settings and enable some parameters functions.

Settings:

Reset parameters settings:

10: Users can reset all parameter values to factory defaults. All parameter values will be reset after re-power the servo drive. (Before perform this settings, ensure that the status of the servo drive is "Servo Off".)

Enable parameters functions:

20: If P2-08 is set to 20, then the parameter P4-10 is enabled.

22: If P2-08 is set to 22, then the parameters P4-11~P4-19 are enabled.

1. Users may lock the parameters and protect parameters against change by unauthorized personnel.

■ Parameter Lock (Password Input):

Enter 5-digit password (your password should be at least five characters long). Confirm your password again and then, the password input is completed. (The highest digit of your password number should be at least set to 1).

Chapter 7 Servo Parameters | ASDA-A&A+ Series

- Set parameters:
Enter correct password, and then you can unlock the parameters and change them.
- Password Decode:
First, enter correct password, and set P2-08 to 0(zero) twice continuously.

P2 - 09	DRT	Bounce Filter	Communication Addr.: 0209H
----------------	------------	----------------------	-----------------------------------

Default: 2

Related Section:

Applicable Control Mode: ALL

Section 6.3.6

Unit: 2ms

Range: 0 ~ 20

Settings:

For example, if P2-09 is set to 5, the bounce filter time is 5 x 2ms=10ms.

When there are too much vibration or noises around environment, increasing this setting value (bounce filter time) can improve reliability. However, if the time is too long, it may affect the response time.

P2 - 10	DI1	Digital Input Terminal 1 (DI1)	Communication Addr.: 020AH
----------------	------------	---------------------------------------	-----------------------------------

Default: 101

Related Section:

Applicable Control Mode: ALL

Table 7.A

Unit: N/A

Range: 0 ~ 147

Settings:

This parameter is used to determine the function and status of DI1.

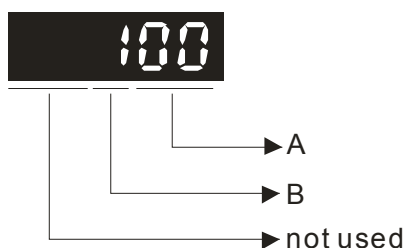

- A: DI Function Settings: For the setting value of P2-10 ~ P2-17, please refer to Table 7.A.
- B: DI Enabled Status Settings:
0: Normally closed (contact b)
1: Normally open (contact a)

Please re-start the servo drive after parameters have been changed.

P2 - 11	DI2	Digital Input Terminal 2 (DI2)	Communication Addr.: 020BH
----------------	------------	---------------------------------------	-----------------------------------

Default: 104

Related Section:

Applicable Control Mode: ALL

Table 7.A

Unit: N/A

Range: 0 ~ 147

Settings: See P2-10 for explanation.

Chapter 7 Servo Parameters | ASDA-A&A+ Series

P2 - 12	DI3	Digital Input Terminal 3 (DI3)	Communication Addr.: 020CH
	Default: 116 Applicable Control Mode: ALL Unit: N/A Range: 0 ~ 147 Settings: See P2-10 for explanation.		Related Section: Table 7.A
P2 - 13	DI4	Digital Input Terminal 4 (DI4)	Communication Addr.: 020DH
	Default: 117 Applicable Control Mode: ALL Unit: N/A Range: 0 ~ 147 Settings: See P2-10 for explanation.		Related Section: Table 7.A
P2 - 14	DI5	Digital Input Terminal 5 (DI5)	Communication Addr.: 020EH
	Default: 102 Applicable Control Mode: ALL Unit: N/A Range: 0 ~ 147 Settings: See P2-10 for explanation.		Related Section: Table 7.A
P2 - 15	DI6	Digital Input Terminal 6 (DI6)	Communication Addr.: 020FH
	Default: 22 Applicable Control Mode: ALL Unit: N/A Range: 0 ~ 147 Settings: See P2-10 for explanation.		Related Section: Table 7.A
P2 - 16	DI7	Digital Input Terminal 7 (DI7)	Communication Addr.: 0210H
	Default: 23 Applicable Control Mode: ALL Unit: N/A Range: 0 ~ 147 Settings: See P2-10 for explanation.		Related Section: Table 7.A

Chapter 7 Servo Parameters | ASDA-A&A+ Series

P2 - 17	DI8	Digital Input Terminal 8 (DI8)	Communication Addr.: 0211H
----------------	------------	---------------------------------------	-----------------------------------

Default: 21

Applicable Control Mode: ALL

Unit: N/A

Range: 0 ~ 147

Settings: See P2-10 for explanation.

Related Section:

Table 7.A

P2 - 18	DO1	Digital Output Terminal 1 (DO1)	Communication Addr.: 0212H
----------------	------------	--	-----------------------------------

Default: 101

Applicable Control Mode: ALL

Unit: N/A

Range: 0 ~ 112

Settings:

This parameter is used to determine the function and status of DO1.

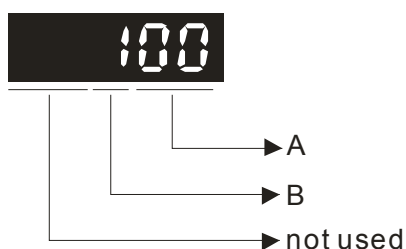

- A: DO Function Settings: For the setting value of P2- 18 ~ P2-22, please refer to Table 7.A.
- B: DO Enabled Status Settings:
0: Normally closed (contact b)
1: Normally open (contact a)

Please re-start the servo drive after parameters have been changed.

P2 - 19	DO2	Digital Output Terminal 2 (DO2)	Communication Addr.: 0213H
----------------	------------	--	-----------------------------------

Default: 103

Applicable Control Mode: ALL

Unit: N/A

Range: 0 ~ 112

Settings: See P2-18 for explanation.

Related Section:

Table 7.B

P2 - 20	DO3	Digital Output Terminal 3 (DO3)	Communication Addr.: 0214H
----------------	------------	--	-----------------------------------

Default: 109

Applicable Control Mode: ALL

Unit: N/A

Range: 0 ~ 112

Settings: See P2-18 for explanation.

Related Section:

Table 7.B

Chapter 7 Servo Parameters | ASDA-A&A+ Series

P2 - 21	DO4	Digital Output Terminal 4 (DO4)	Communication Addr.: 0215H
----------------	------------	--	-----------------------------------

Default: 105

Related Section:

Applicable Control Mode: ALL

Table 7.B

Unit: N/A

Range: 0 ~ 112

Settings: See P2-18 for explanation.

P2 - 22	DO5	Digital Output Terminal 5 (DO5)	Communication Addr.: 0216H
----------------	------------	--	-----------------------------------

Default: 7

Related Section:

Applicable Control Mode: ALL

Table 7.B

Unit: N/A

Range: 0 ~ 112

Settings: See P2-18 for explanation.

P2 - 23	NCF	Notch Filter (Resonance Suppression)	Communication Addr.: 0217H
----------------	------------	---	-----------------------------------

Default: 1000

Related Section:

Applicable Control Mode: ALL

Section 6.3.7

Unit: Hz

Range: 50 ~ 1000

Settings:

This parameter is used to set resonance frequency of mechanical system. It can be used to suppress the resonance of mechanical system. If P2-24 is set to 0, this parameter is disabled.

P2 - 24	DPH	Notch Filter Attenuation Rate (Resonance Suppression)	Communication Addr.: 0218H
----------------	------------	--	-----------------------------------

Default: 0

Related Section:

Applicable Control Mode: ALL

Section 6.3.7

Unit: dB

Range: 0 ~ 32

Settings: 0: Disabled

Chapter 7 Servo Parameters | ASDA-A&A+ Series

P2 - 25	NLP	Low-pass Filter Time Constant (Resonance Suppression)	Communication Addr.: 0219H
----------------	------------	--	-----------------------------------

Default: 2 (1kW and below models) or
5 (above 1kW models)

Related Section:
Section 6.3.7

Applicable Control Mode: ALL

Unit: ms

Range: 0 ~ 1000

Settings: 0: Disabled

This parameter is used to set low-pass filter time constant of resonance suppression.

P2 - 26	DST	External Anti-Interference Gain	Communication Addr.: 021AH
----------------	------------	--	-----------------------------------

Default: 0

Related Section: N/A

Applicable Control Mode: ALL

Unit: 0.001

Range: 0 ~ 30000 (ASDA-A series)
0 ~ 1023 (ASDA-A+ series)

Settings:

0: Disabled

In AutoMode (PDFF) mode (parameter P2-32 is set to 4 or 5), the value of this parameter is determined by the system automatically.

P2 - 27	GCC	Gain Switching Control Selection	Communication Addr.: 021BH
----------------	------------	---	-----------------------------------

Default: 0

Related Section: N/A

Applicable Control Mode: ALL

Unit: N/A

Range: 0 ~ 4

Settings:

Gain Switching Condition Settings:

0: Disabled

1: Gain switching DI signal (GAINUP) is On. (see Table 7.A)

2: In position mode, position deviation is higher than the setting value of P2-29.

3: Position command frequency is higher than the setting value of P2-29.

4: Servo motor speed is higher than the setting value of P2-29.

Chapter 7 Servo Parameters | ASDA-A&A+ Series

P2 - 28

GUT	Gain Switching Time Constant	Communication Addr.: 021CH
------------	-------------------------------------	-----------------------------------

Default: 10

Related Section: N/A

Applicable Control Mode: ALL

Unit: 10ms

Range: 0 ~ 1000

Settings: 0: Disabled

This parameter is used to set the time constant when switching the smooth gain.

P2 - 29

GPE	Gain Switching Condition	Communication Addr.: 021DH
------------	---------------------------------	-----------------------------------

Default: 10000

Related Section: N/A

Applicable Control Mode: ALL

Unit: pulse, Kpps, r/min

Range: 0 ~ 30000

Settings: 0: Disabled

This parameter is used to set the value of gain switching condition (pulse error, Kpps, r/min) selected in P2-27. The setting value will be different depending on the different gain switching condition.

P2 - 30

INH	Auxiliary Function	Communication Addr.: 021EH
------------	---------------------------	-----------------------------------

Default: 0

Related Section: N/A

Applicable Control Mode: ALL

Unit: N/A

Range: 0 ~ 5

Settings:

0: Normal operation of Digital Inputs SON, CW, and CCW.

1: Force the servo drive to be Servo On (ignore CW and CCW signal)

2: Ignore CW digital input signal

3: Ignore CCW digital input signal

4: Internal position learning function

5: After setting P2-30 to 5, the setting values of all parameters will lost (not remain in memory) at power-down. When the parameters data are no more needed, using this mode can allows users not to save parameters data into memory without damaging the EEPROM.



- 1) Please set P2-30 to 0 during normal operation. When the communication control function is used, ensure that P2-30 is set to 5. The setting value of P2-30 will return to 0 automatically after re-power the servo drive.

Chapter 7 Servo Parameters | ASDA-A&A+ Series**P2 - 31****AUT1****Auto Mode Responsiveness Level****Communication Addr.: 021FH**

Default: 44

Related Section:

Applicable Control Mode: ALL

Section 5.6, Section 6.3.6

Unit: N/A

Range: 0 ~ FF (0 ~ FF: 0 indicates the lowest setting and F indicates the highest setting (total 16 settings available))

Settings:

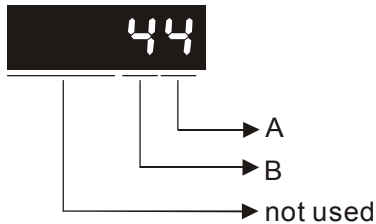

ASDA-A series:

This parameter allows the users to set the stiffness setting of easy mode and the responsiveness level of auto-tuning mode. Users can control the stiffness and responsiveness according to application condition. When the setting value is higher, the stiffness and the responsiveness is higher.

A: Stiffness setting of easy mode

B: Responsiveness level of auto-tuning mode

ASDA-A+ series:

This parameter allows the users to set the responsiveness level setting of auto-tuning mode. Users can control the responsiveness according to application condition. When the setting value is higher, the responsiveness is higher.

A: No function

B: Responsiveness level of auto-tuning mode



- 1) This parameter is activated by P2-32.
- 2) Please refer to Section 5.6 for the tuning procedure and the related settings.

Chapter 7 Servo Parameters | ASDA-A&A+ Series

P2 - 32▲	AUT2	Tuning Mode Selection	Communication Addr.: 0220H
-----------------	-------------	------------------------------	-----------------------------------

Default: 0

Related Section:

Applicable Control Mode: ALL

Section 5.6, Section 6.3.6

Unit: N/A

Range: 0 ~ 5

Settings:

0: Manual mode

1: Easy mode (for ASDA-A series only, ASDA-A+ series does not support this mode)

2: AutoMode (PI) [Continuous adjustment]

3: AutoMode (PI) [Fix the ratio of Load Inertia to servo motor inertia and response level can be adjusted]

4: AutoMode (PDFF) [Continuous adjustment]

5: AutoMode (PDFF) [Fix the ratio of Load Inertia to servo motor inertia and response level can be adjusted]

PI : Proportional - Integral control

PDFF : Pseudo-Derivative Feedback and Feedforward

Explanation of Auto-tuning:

1. When switching mode #2 or #4 to #3 or #5, the system will save the measured load inertia value automatically and memorized in P1-37. Then, set the corresponding parameters according to this measured load inertia value.
2. When switching mode #2 or #4 to #0, it indicates all automatically measured load inertia value will be aborted, and all setting of parameters will be returned to original setting value in #0 manual mode.
3. When switching mode #0 to #3 or #5, enter the appropriate load inertia value in P1-37.
4. When switching mode #3 to #0, the setting value of P2-00, P2-04 and P2-06 will change to the value that measured in #3 auto-tuning mode.
5. When switching mode #5 to #0, the setting value of P2-00, P2-04, P2-06, P2-25 and P2-26 will change to the value that measured in #5 auto-tuning mode

Chapter 7 Servo Parameters | ASDA-A&A+ Series

P2 - 33▲	INF	Easy Setting of Input Filter	Communication Addr.: 0221H
-----------------	------------	-------------------------------------	-----------------------------------

Default: 0

Related Section:

Applicable Control Mode: ALL

Section 6.3.6

Unit: N/A

Range: 00 ~ 19

Settings:

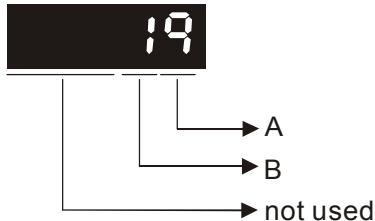

- A=1: Enable this function

- B: Speed selection

B=0 ↓ Low speed

B=9 ↓ High speed

P2 - 34	SDEV	Overspeed Warning Condition	Communication Addr.: 0222H
----------------	-------------	------------------------------------	-----------------------------------

Default: 5000

Related Section: N/A

Applicable Control Mode: S

Unit: r/min

Range: 1 ~ 5000

Settings:

This parameter is used to set the over speed threshold that is used to determine the over speed fault condition. When the difference in speed between the desired speed and actual motor speed is over than the setting value of parameter P2-34, the servo fault, Overspeed (ALE07) will be activated.

P2 - 35	PDEV	Excessive Error Warning Condition	Communication Addr.: 0223H
----------------	-------------	--	-----------------------------------

Default: 30000

Related Section: N/A

Applicable Control Mode: Pt, Pr

Unit: pulse (ASDA-A series, Pr mode of ASDA-A+ series)

1/10000 rev. (Pt mode of ASDA-A+ series)

Range: 1 ~ 30000

Settings:

This parameter is used to set the position deviation excessive error threshold that is used to determine the excessive deviation fault condition. When the difference in pulse number between the desired position and actual motor position is over than the setting value of parameter P2-35, the servo fault, Excessive Deviation (ALE09) will be activated.

Chapter 7 Servo Parameters | ASDA-A&A+ Series

P2 - 36	POV1	Moving Speed Setting of 1st Position	Communication Addr.: 0224H
Default: 1000		Related Section:	
Applicable Control Mode: Pr		Section 6.2.2	
Unit: r/min			
Range: 1 ~ 5000			
Settings:			
When setting value of P2-36 to P2-43 is higher than 3000 r/min, please set the setting value of P1-55 to its maximum value.			

P2 - 37	POV2	Moving Speed Setting of 2nd Position	Communication Addr.: 0225H
Default: 1000		Related Section:	
Applicable Control Mode: Pr		Section 6.2.2	
Unit: r/min			
Range: 1 ~ 5000			
Settings:			
Please refer to P2-36.			

P2 - 38	POV3	Moving Speed Setting of 3rd Position	Communication Addr.: 0226H
Default: 1000		Related Section:	
Applicable Control Mode: Pr		Section 6.2.2	
Unit: r/min			
Range: 1 ~ 5000			
Settings:			
Please refer to P2-36.			

P2 - 39	POV4	Moving Speed Setting of 4th Position	Communication Addr.: 0227H
Default: 1000		Related Section:	
Applicable Control Mode: Pr		Section 6.2.2	
Unit: r/min			
Range: 1 ~ 5000			
Settings:			
Please refer to P2-36.			

Chapter 7 Servo Parameters | ASDA-A&A+ Series

P2 - 40	POV5	Moving Speed Setting of 5th Position	Communication Addr.: 0228H
----------------	-------------	---	-----------------------------------

Default: 1000

Related Section:

Applicable Control Mode: Pr

Section 6.2.2

Unit: r/min

Range: 1 ~ 5000

Settings:

Please refer to P2-36.

P2 - 41	POV6	Moving Speed Setting of 6th Position	Communication Addr.: 0229H
----------------	-------------	---	-----------------------------------

Default: 1000

Related Section:

Applicable Control Mode: Pr

Section 6.2.2

Unit: r/min

Range: 1 ~ 5000

Settings:

Please refer to P2-36.

P2 - 42	POV7	Moving Speed Setting of 7th Position	Communication Addr.: 022AH
----------------	-------------	---	-----------------------------------

Default: 1000

Related Section:

Applicable Control Mode: Pr

Section 6.2.2

Unit: r/min

Range: 1 ~ 5000

Settings:

Please refer to P2-36.

P2 - 43	POV8	Moving Speed Setting of 8th Position	Communication Addr.: 022BH
----------------	-------------	---	-----------------------------------

Default: 1000

Related Section:

Applicable Control Mode: Pr

Section 6.2.2

Unit: r/min

Range: 1 ~ 5000

Settings:

Please refer to P2-36.

Chapter 7 Servo Parameters | ASDA-A&A+ Series

P2 - 44	DOM	Digital Output Mode Setting	Communication Addr.: 022CH
		Default: 0	Related Section:
		Applicable Control Mode: Pr	Section 12.6
		Unit: N/A	
		Range: 0 ~ 1	
		Settings:	
This parameter determines that the digital output equals the setting value of P2-18 ~ P2-22 or INDEX positions when using feed step control function and in internal auto running mode (See Chapter 12 for explanation).			
0: General output mode, digital output function is defined by the setting value of P2-18 ~ P2-22.			
1: Combination output mode			
When the users want to use feed step control function, this output mode must be selected. Otherwise, the feed step control function can not be used normally. (Refer to Section 12.6)			
When the users want to use internal auto running mode function, this output mode must be selected. Otherwise, the output signal can not be converted to combination output signal normally. (Refer to Section 12.7)			

P2 - 45	DOD	Combination Output Signal Delay Time	Communication Addr.: 022DH
		Default: 1	Related Section:
		Applicable Control Mode: Pr	Section 12.6
		Unit: 4ms	
		Range: 0 ~ 250	
		Settings:	
This parameter can be used only when P2-44 is set to 1. The users can use this parameter to set the ON time delay when positioning is completed.			

P2 - 46	FSN	Feed Step Number	Communication Addr.: 022EH
		Default: 6	Related Section:
		Applicable Control Mode: Pr	Section 12.6
		Unit: sec	
		Range: 2 ~ 32	

Chapter 7 Servo Parameters | ASDA-A&A+ Series

P2 - 47	PED	Position Deviation Clear Delay Time	Communication Addr.: 022FH
Default: 0		Related Section:	
Applicable Control Mode: Pr		Section 12.6	
Unit: 20ms			
Range: 0 ~ 250			
Settings:			
This function is disabled when its setting value is set to 0.			

P2 - 48	BLAS	Backlash Compensation of Feed Step Control	Communication Addr.: 0230H
Default: 0		Related Section:	
Applicable Control Mode: Pr		Section 12.6	
Unit: pulse			
Range: 0 ~ 10312			
Settings:			

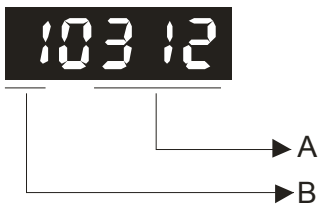

- A: Pulse Number Settings
0 ~ 312, the pulse number of backlash compensation
Actual pulse number of backlash compensation of motor output shaft is equal to the number of value A x electronic gear ratio
- B: Polarity Settings
B=0: Forward compensation
B=1: Reverse compensation

 **NOTE**

- 1) After modifying the setting value, execute the home sensor function. After executing the home sensor function, perform the control function.

Chapter 7 Servo Parameters | ASDA-A&A+ Series

P2 - 49	SJIT	Speed Detection Filter and Jitter Suppression	Communication Addr.: 0231H
----------------	-------------	--	-----------------------------------

Default: 0

Related Section: N/A

Applicable Control Mode: ALL

Unit: sec

Range: 0 ~ 19

Settings:

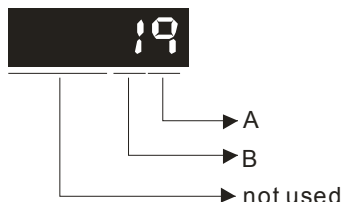

- A: Speed Detection Filter Constant
Range: 0 ~ 9
- B: Enable/Disable Jitter Suppression Function
B=0: Disable Jitter Suppression function
B=1: Enable Jitter Suppression function

When this function is enabled, it can suppress the jitter created when the motor stops at a position.

P2 - 50	DCLR	Pulse Deviation Clear Mode	Communication Addr.: 0232H
----------------	-------------	-----------------------------------	-----------------------------------

Default: 0

Related Section: N/A

Applicable Control Mode: Pt, Pr

Unit: N/A

Range: 0 ~ 2

Settings:

For digital input function (DI function), please refer to Table 7.A.

This pulse deviation clear function is enabled when a digital input is set to pulse clear function (CCLR mode, DI function is set to 4).

- 0: Clear position pulse deviation number (available in Pt and Pr mode only)
When this input is triggered, the position accumulated pulse number will be clear to 0.
- 1: Clear motor feedback pulse and rotation number (available in Pt and Pr mode only)
When this input is triggered, the count pulse and rotation number will be clear to 0. This zero point will be regarded as the "Home" of the motor.
- 2: Clear remaining position pulses and interrupt the motor operation (available Pr mode only).
If CCLR signal is ON when the motor is running, the motor will decelerate first and stop according to the deceleration time which is set by parameter P1-34 ~ P1-36 and the remaining pulses will be aborted. When TRIG signal is ON again, the motor will continue to move forward and reach the target position that is set currently.

Chapter 7 Servo Parameters | ASDA-A&A+ Series

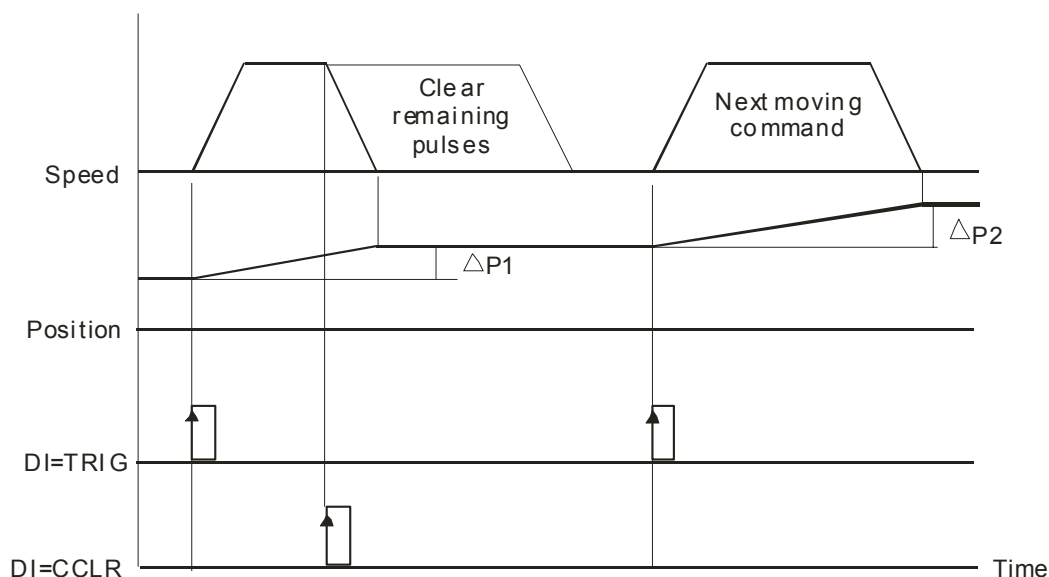

P2 - 51

SRON
Servo ON
Communication Addr.: 0233H

Default: 0

Related Section: N/A

Applicable Control Mode: ALL

Unit: N/A

Range: 0 ~ 1

Settings:

0: Servo ON (SON) is activated via Digital Input signal

1: Servo ON (SON) is activated when control power is applied the servo drive (not via Digital Input signal)

Servo ON (SON) is "ON" with control power applied to the servo drive, there may be a fault condition or not. The servo is not ready to run. Servo ready (SRDY) is "ON" where the servo is ready to run, NO fault / alarm exists. (P2-51 should turn servo ready SRDY off / on)

P2 - 52

ATM0
Timer 0 of Auto Mode
Communication Addr.: 0234H

Default: 0

Related Section: N/A

Applicable Control Mode: Pr

Unit: sec

Range: 0 ~ 120.00

P2 - 53

ATM1
Timer 1 of Auto Mode
Communication Addr.: 0235H

Default: 0

Related Section: N/A

Applicable Control Mode: Pr

Unit: sec

Range: 0 ~ 120.00

Chapter 7 Servo Parameters | ASDA-A&A+ Series**P2 - 54****ATM2****Timer 2 of Auto Mode****Communication Addr.: 0236H**

Default: 0

Related Section: N/A

Applicable Control Mode: Pr

Unit: sec

Range: 0 ~ 120.00

P2 - 55**ATM3****Timer 3 of Auto Mode****Communication Addr.: 0237H**

Default: 0

Related Section: N/A

Applicable Control Mode: Pr

Unit: sec

Range: 0 ~ 120.00

P2 - 56**ATM4****Timer 4 of Auto Mode****Communication Addr.: 0238H**

Default: 0

Related Section: N/A

Applicable Control Mode: Pr

Unit: sec

Range: 0 ~ 120.00

P2 - 57**ATM5****Timer 5 of Auto Mode****Communication Addr.: 0239H**

Default: 0

Related Section: N/A

Applicable Control Mode: Pr

Unit: sec

Range: 0 ~ 120.00

P2 - 58**ATM6****Timer 6 of Auto Mode****Communication Addr.: 023AH**

Default: 0

Related Section: N/A

Applicable Control Mode: Pr

Unit: sec

Range: 0 ~ 120.00

P2 - 59**ATM7****Timer 7 of Auto Mode****Communication Addr.: 023BH**

Default: 0

Related Section: N/A

Applicable Control Mode: Pr

Unit: sec

Range: 0 ~ 120.00

Chapter 7 Servo Parameters | ASDA-A&A+ Series

P2 - 60	GR4	Electronic Gear Ratio (2nd Numerator) (N2)	Communication Addr.: 023CH
----------------	------------	---	-----------------------------------

Default: 1

Related Section: N/A

Applicable Control Mode: Pt, Pr

Unit: pulse

Range: 1 ~ 32767

Settings:

The electronic gear numerator value can be set via GNUM0, GNUM1 (refer to Table 7.A).

When the GNUM0, GNUM1 are not defined, the default of gear numerator value is set by P1-44.

When the users wish to set the gear numerator value by using GNUM0, GNUM1, please set P2-60 ~ P2-62 after the servo motor has been stopped.

P2 - 61	GR5	Electronic Gear Ratio (3rd Numerator) (N3)	Communication Addr.: 023DH
----------------	------------	---	-----------------------------------

Default: 1

Related Section: N/A

Applicable Control Mode: Pt, Pr

Unit: pulse

Range: 1 ~ 32767

Settings:

Please refer to P2-60.

P2 - 62	GR6	Electronic Gear Ratio (4th Numerator) (N4)	Communication Addr.: 023EH
----------------	------------	---	-----------------------------------

Default: 1

Related Section: N/A

Applicable Control Mode: Pt, Pr

Unit: pulse

Range: 1 ~ 32767

Settings:

Please refer to P2-60.

Chapter 7 Servo Parameters | ASDA-A&A+ Series

P2 - 63

TSCA

Proportion Value Setting

Communication Addr.: 023FH

Default: 0

Related Section: N/A

Applicable Control Mode: Pt, S

Unit: times

Range: 0 ~ 11

Settings:

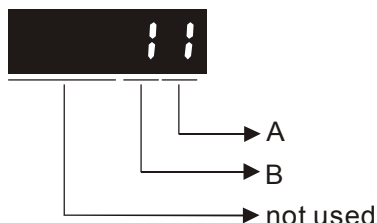

A: Decimal place setting of internal speed command.

0: When value A is set to 0, the unit of P1-09~P1-11 is 1 r/min (No decimal place setting)

1: When value A is set to 1, the unit of P1-09~P1-11 is 0.1 r/min (One decimal place setting)

If P1-09 is set to 1234, and value A is set to 0, and then the internal speed is 1234 r/min.

If P1-09 is set to 1234, and value A is set to 1, and then the internal speed is 123.4 r/min.

This setting value A is available for internal speed command only, not available for speed limit command.

B: Proportion value setting of position excessive error warning condition (P2-35)

ASDA-A series

0: When value B is set to 0, the unit of P2-35 is 1 pulse

1: When value B is set to 1, the unit of P2-35 is 100 pulses

If P2-35 is set to 1000, and value B is set to 0, the position excessive error warning pulse is 1000 pulses.

If P2-35 is set to 1000, and value B is set to 1, the position excessive error warning pulse is 100,000 pulses.

ASDA-A+ series

0: When value B is set to 0, the unit of P2-35 is 1/10000 rev.

1: When value B is set to 1, the unit of P2-35 is 1/100 rev.

If P2-35 is set to 1000, and value B is set to 0, the position excessive error warning pulse is 0.1 rev.

If P2-35 is set to 1000, and value B is set to 1, the position excessive error warning pulse is 10 rev.

Chapter 7 Servo Parameters | ASDA-A&A+ Series

P2 - 64
TLMOD Torque Limit Mixed Mode
Communication Addr.: 0240H

Default: 0

Related Section: N/A

Applicable Control Mode: Pt, Pr, S

Unit: N/A

Range: 0 ~ 3

Settings:

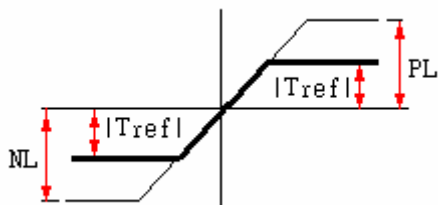

PL: Positive Limit

NL: Negative Limit

Tref: Torque Analog Input Voltage

Tpl: Actual PL value in "Torque Limit Mixed Mode"

Tnl: Actual NL value in "Torque Limit Mixed Mode"

0: Disabled

1: Torque limit mixed mode (No polarity)

 If $|T_{ref}| < PL$, $T_{pl} = |T_{ref}|$

 If $|T_{ref}| > PL$, $T_{pl} = PL$

 If $|T_{ref}| < NL$, $T_{nl} = |T_{ref}|$

 If $|T_{ref}| > NL$, $T_{nl} = NL$

2: Torque limit mixed mode (Positive)

 If $0 < T_{ref} < PL$, $T_{pl} = T_{ref}$

 If $T_{ref} > PL$, $T_{pl} = PL$

 If $T_{ref} < 0$, $T_{pl}, T_{nl} = 0$

3: Torque limit mixed mode (Negative)

 If $T_{ref} > 0$, $T_{pl}, T_{nl} = 0$

 If $-NL < T_{ref} < 0$, $T_{nl} = -T_{ref}$

 If $T_{ref} < -NL$, $T_{nl} = NL$

This parameter can allow the users to set two different kinds of torque limit command sources when limiting torque. We call it is "Torque Limit Mixed Mode".

The torque limit function is activated by parameter P1-02 or via digital input TRQLM, TLLM or TRLM.

If the users use TRQLM or P1-02 to activate torque limit function, the torque limit command source can be analog input or internal parameters (P1-12 to P1-14) depending on which way you use to activate torque limit function. At this time, the limit of PL and NL in the figure below are specified as the torque limit that determined by the torque limit command source.

If the users use TLLM or TRLM to activate torque limit function, the torque limit command source can be parameter P1-12 (NL) or P1-13 (PL).

Chapter 7 Servo Parameters | ASDA-A&A+ Series

P2 - 65

GBIT	Special Function	Communication Addr.: 0241H
-------------	-------------------------	-----------------------------------

Default: 0

Related Section: N/A

Applicable Control Mode: Pr, Pt, S

Unit: N/A

Range: 0 ~ 3

Settings:

Bit15	Bit14	Bit13	Bit12	Bit11	Bit10	Bit9	Bit8	Bit7	Bit6	Bit5	Bit4	Bit3	Bit2	Bit1	Bit0
-------	-------	-------	-------	-------	-------	------	------	------	------	------	------	------	------	------	------

Bit1	Bit0
------	------

Bit0: DI SPD0/SPD1 speed command trigger mode

0: by level

1: by rising edge

Bit1: DI TCM0/TCM1 torque command trigger mode

0: by level

1: by rising edge

When the servo drive is rising-edge triggered, the internal commands work as follows:

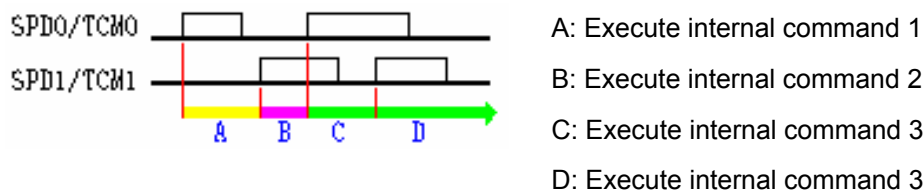

Bit4	Bit3	Bit2
------	------	------

Fast DI (digital input) function. When this function is activated, the function of P2-17(DI8) will become invalid and change to Fast DI (digital input) function. When Bit3 ~ Bit4 are all set to 0, this fast DI (digital input) function is disabled.

Bit2: Fast DI contact type

0: normal open or rising edge trigger

1: normal close or falling edge trigger

Bit3 ~ Bit4: Fast DI function definition

Bit4	Bit3	Function
0	0	Disable fast DI function
0	1	Fast position latch for DI8 : When fast position latch function is enabled, the users can get latch position from LED display by setting P0-02=15 (latch pulses) or setting P0-02=16 (latch revolutions) . The users also can get the position through the communication by setting P0-04 ~ P0-08.
1	0	Fast DI INHIBIT for DI8 Response time of the normal DI is 0.4 ~ 0.6ms Response time of this fast DI is 0.0 ~ 0.1ms

Please note that Bit3 and Bit4 cannot be activated simultaneously.

Chapter 7 Servo Parameters | ASDA-A&A+ Series

Bit5: Reserved. Must be set to 0.

Bit6

Bit6: Abnormal pulse command detection

0: enable abnormal pulse command detection

1: disable abnormal pulse command detection,

Bit7 ~ Bit9: Reserved. Must be set to 0.

Bit10

Bit10: DI ZCLAMP function selection

0: Locked at the position when ZCLAMP conditions are satisfied.

1: Speed command is forced to 0 r/min when ZCLAMP conditions are satisfied.

How to select these two functions?

If the users want to use the edge of a D1 signal to stop the motor at the desired position and do not care the speed deceleration curve, then set Bit10 of P2-65 to 0.

If the users want to eliminate the analog voltage offset to stop the motor at low voltage and they want to keep the acceleration and deceleration speed curve, then set Bit10 of P2-65 to 1.

When the following conditions are all met, ZCLAMP function will be activated.

Condition1: Speed mode

Condition2: DI ZCLAMP is activated.

Condition3: External analog speed command or internal registers speed command is less than parameter P1-38.

Bit11: Reserved. Must be set to 0.

B13	B12
-----	-----

Bit 12: Undervoltage (Servo Drive Fault) clear mode selection

0: When the main circuit voltage is within its specified limit or after Servo Off (the servo drive is disabled), the fault, Undervoltage will be cleared automatically.

1: When turning ARST (DI signal) to be ON and the main circuit voltage is within its specified limit also, the fault, Undervoltage will be cleared.

Bit 13: CWL/CCWL pulse input inhibit function

0: Disable CWL/CCWL pulse input inhibit function. In Pt mode, no matter CWL or CCWL exists or not, external position pulse command will be input into the servo drive.

1: Enable CWL/CCWL pulse input inhibit function. In Pt mode, if CWL exists, the external CWL pulse input into the servo drive will be inhibited and CCWL pulse input will be accepted. On the one hand, in Pt mode, if CCWL exists, , the external CCWL pulse input into the servo drive will be inhibited and CCWL pulse input will be accepted. Please note that if CWL and CCWL both exist, CWL and CCWL pulse input into the servo drive will be both inhibited.

Bit14 ~ Bit15: Reserved. Must be set to 0.

Chapter 7 Servo Parameters | ASDA-A&A+ Series

P2 - 66	Reserved	Communication Addr.: 0242H
P2 - 67	Reserved	Communication Addr.: 0243H
P2 - 68	Reserved	Communication Addr.: 0244H

Chapter 7 Servo Parameters | ASDA-A&A+ Series

Group 3: P3-xx Communication Parameters

P3 - 00	ADR	Communication Address Setting	Communication Addr.: 0300H
----------------	------------	--------------------------------------	-----------------------------------

Default: 1

Applicable Control Mode: ALL

Unit: N/A

Range: 1~254

Settings:

If the AC servo drive is controlled by RS-232/485/422 communication, each drive (or device) must be uniquely identified and addressed between 1 and 254. Access to program this number is via parameter P3-00.

One servo drive only can set one address. If the address is duplicate, there will be a communication fault.



- 1) When the address of host (external) controller is set to 0, it is with broadcast function. Then, the servo drive will receive from host (external) controller only and will not respond to host (external) controller no matter the address is matching or not.
- 2) When the address of host (external) controller is set to 255, it is with auto-respond function. Then, the servo drive will receive from and respond to host (external) controller both no matter the address is matching or not.

P3 - 01	BRT	Transmission Speed	Communication Addr.: 0301H
----------------	------------	---------------------------	-----------------------------------

Default: 1

Applicable Control Mode: ALL

Unit: bps

Range: 0~5

Settings:

0: Baud rate 4800 (data transmission speed: bits / second)

1: Baud rate 9600 (data transmission speed: bits / second)

2: Baud rate 19200 (data transmission speed: bits / second)

3: Baud rate 38400 (data transmission speed: bits / second)

4: Baud rate 57600 (data transmission speed: bits / second)

5: Baud rate 115200 (data transmission speed: bits / second)

This parameter is used to set the desired transmission speed between the computer and AC servo drive. Users can set this parameter and control transmission speed to reach the maximum baud rate of 115200 bps.

Chapter 7 Servo Parameters | ASDA-A&A+ Series

P3 - 02	PTL	Communication Protocol	Communication Addr.: 0302H
Default: 0		Related Section:	
Applicable Control Mode: ALL		Section 8.2	
Unit: N/A			
Range: 0~8			
Settings:			
0: Modbus ASCII mode, <7,N,2>			
1: Modbus ASCII mode, <7,E,1 >			
2: Modbus ASCII mode, <7,O,1>			
3: Modbus ASCII mode, <8,N,2 >			
4: Modbus ASCII mode, <8,E,1>			
5: Modbus ASCII mode, <8,O,1>			
6: Modbus RTU mode, <8,N,2>			
7: Modbus RTU mode, <8,E,1>			
8: Modbus RTU mode, <8,O,1>			
<p>This parameter is used to set the communication protocol. The alphanumeric characters represent the following: 7 or 8 is the number of data bits; N, E or O refer to the parity bit, Non, Even or Odd; the 1 or 2 is the numbers of stop bits.</p>			

P3 - 03	FLT	Transmission Fault Treatment	Communication Addr.: 0303H
Default: 0		Related Section:	
Applicable Control Mode: P, S, T		Section 8.2	
Unit: N/A			
Range: 0~1			
Settings:			
0: Display fault and continue operating			
1: Display fault and stop operating			
<p>This parameter is used to determine the operating sequence once a communication fault has been detected. If '1' is selected, the drive will stop operating upon detection the communication fault. The mode of stopping is set by parameter P1-32.</p>			

Chapter 7 Servo Parameters | ASDA-A&A+ Series

P3 - 04	CWD	Communication Time Out Detection	Communication Addr.: 0304H
Default: 0		Related Section:	
Applicable Control Mode: ALL		Section 8.2	
Unit: N/A			
Range: 0~20			
Settings:			
0: Disabled			
<p>This parameter is used to set the maximum permissible time before detecting a fault due to communication time out. When this parameter is set to a value over than 0, it indicates this function is enabled. However, if not communicating with the servo in this period of time, the servo drive will assume the communication has failed and show the communication error fault message.</p>			

P3 - 05	CMM	Communication Selection	Communication Addr.: 0305H
Default: 0		Related Section:	
Applicable Control Mode: ALL		Section 8.2	
Unit: N/A			
Range: 0~2			
Settings:			
0: RS-232			
1: RS-422			
2: RS-485			
<p>Multiple communication modes RS232, RS-485, RS-422 cannot be used within one communication ring.</p>			

Chapter 7 Servo Parameters | ASDA-A&A+ Series

P3 - 06	SDI	Digital Input Communication Function	Communication Addr.: 0306H
----------------	------------	---	-----------------------------------

Default: 0

Related Section:

Applicable Control Mode: ALL

P4-07, Section 8.2

Unit: N/A

Range: 0~FFFF

Settings:

The setting of this parameter determines how the Digital Inputs (DI) accept commands and signals. If the Digital Input Contact Control parameter for the DI 1 ~ DI 8 is set to "0", command is external, and via CN1; if it is set to "1" the DI signal is via communication.

Bit0 ~ Bit 7 corresponds with DI1 ~ DI8. The least significant bit (Bit0) shows DI1 status and the most significant bit (Bit7) shows DI8 status. The new DI9 ~ DI16 for software communication corresponds with CTRG / POS0 / POS1 / POS2 / ARST / SHOM / JOGU / JOGD these signals.

The Digital Input Control Contact parameter, P3-06 also works in conjunction with the Multi Function Digital Input parameter P4-07 which has several functions. Please see section 8.2 for details.

P3 - 07	CDT	Communication Response Delay Time	Communication Addr.: 0307H
----------------	------------	--	-----------------------------------

Default: 0

Related Section: N/A

Applicable Control Mode: ALL

Unit: 0.5ms

Range: 0~255

Settings:

This parameter is used to delay the communication time that servo drive responds to host controller (external controller).



- 1) When the address of host (external) controller is set to 255, no matter what the setting value of parameter P1-37 is, the communication response delay time will be 0 always.

Chapter 7 Servo Parameters | ASDA-A&A+ Series**Group 4: P4-xx Diagnosis Parameters**

P4 - 00★	ASH1	Fault Record (N)	Communication Addr.: 0400H
-----------------	-------------	-------------------------	-----------------------------------

Default: 0

Applicable Control Mode: ALL

Unit: N/A

Range: N/A

Settings:

The latest fault record.

Related Section:

Section 4.4.1

P4 - 01★	ASH2	Fault Record (N-1)	Communication Addr.: 0401H
-----------------	-------------	---------------------------	-----------------------------------

Default: 0

Applicable Control Mode: ALL

Unit: N/A

Range: N/A

Related Section:

Section 4.4.1

P4 - 02★	ASH3	Fault Record (N-2)	Communication Addr.: 0402H
-----------------	-------------	---------------------------	-----------------------------------

Default: 0

Applicable Control Mode: ALL

Unit: N/A

Range: N/A

Related Section:

Section 4.4.1

P4 - 03★	ASH4	Fault Record (N-3)	Communication Addr.: 0403H
-----------------	-------------	---------------------------	-----------------------------------

Default: 0

Applicable Control Mode: ALL

Unit: N/A

Range: N/A

Related Section:

Section 4.4.1

P4 - 04★	ASH5	Fault Record (N-4)	Communication Addr.: 0404H
-----------------	-------------	---------------------------	-----------------------------------

Default: 0

Applicable Control Mode: ALL

Unit: N/A

Range: N/A

Related Section:

Section 4.4.1

Chapter 7 Servo Parameters | ASDA-A&A+ Series

P4 - 05**JOG****JOG Operation****Communication Addr.: 0405H**

Default: 20

Related Section:

Applicable Control Mode: ALL

Section 4.4.2

Unit: r/min

Range: 0~5000

Settings:

JOG operation command:

1. Operation Test

- (1) Press the SET key to display the JOG speed. (The default value is 20 r/min).
- (2) Press the UP or DOWN arrow keys to increase or decrease the desired JOG speed. (This also can be undertaken by using the SHIFT key to move the cursor to the desired unit column (the effected number will flash) then changed using the UP and DOWN arrow keys).
- (3) Press the SET when the desired JOG speed is displayed. The Servo Drive will display "JOG".
- (4) Press the UP or DOWN arrow keys to jog the motor either CCW or CW. The motor will only rotation while the arrow key is activated.
- (5) To change JOG speed again, press the MODE key. The servo Drive will display "P4 - 05". Press the SET key and the JOG speed will displayed again. Refer back to #(2) and #(3) to change speed.

2. DI Signal Control

Set the value of DI signal as JOGU and JOGD (refer to Table 7.A).

Users can perform JOG run forward and run reverse control.

3. Communication Control

To perform a JOG Operation via communication command, use communication address 0405H

- (1) Enter 0 ~ 3000 for the desired JOG speed
- (2) Enter 4998 to JOG in the CCW direction
- (3) Enter 4999 to JOG in the CW direction
- (4) Enter 5000 to stop the JOG operation

**NOTE**

- 1) If the communication write-in frequency is too high, please set P2-30 to 5.

Chapter 7 Servo Parameters | ASDA-A&A+ Series

P4 - 06 ▲ ■	FOT	Force Output Control	Communication Addr.: 0406H
	<p>Default: 0</p> <p>Applicable Control Mode: ALL</p> <p>Unit: N/A</p> <p>Range: 0~0x1F</p> <p>Settings:</p> <p>Settings:</p> <p>0: Disabled.</p> <p>When the value of P4-06 is a non-zero value, it indicates this function is enabled.</p> <p>This parameter is used to check if there is any damage DO terminal. This parameter is not effective when the servo drive is enabled (Servo ON).</p>		<p>Related Section:</p> <p>Section 4.4.4</p>

NOTE

- 1) When users select P4-06 and press the Set key, the display will show "OP xx". "xx" stands for the parameter range from 00 to 1F (For the example display, refer to Section 4.4.4).

P4 - 07 ■	ITST	Input Status or Force Input Control	Communication Addr.: 0407H
	<p>Default: 0</p> <p>Applicable Control Mode: ALL</p> <p>Unit: N/A</p> <p>Range: 0~FFFF</p> <p>Settings:</p> <p>Please see P3-06 and Section 8.2 for setting method.</p> <p>External Control: Display the status of DI input signal</p> <p>Communication Control: Read the status of input signal (upon software)</p> <p>For the status of DI input signal, please refer to P2-10 ~ P2-17.</p> <p>The contents of P4-07 is "read only" via the drive keypad or the communication software and will display the state on or off of the six Digital Inputs which have been set in accordance to P3-06. The least significant bit (Bit 0) stands for Digital Inputs 1 (DI 1) and the most significant bit (Bit7) stands for Digital Inputs 8 (DI 8).</p>		<p>Related Section:</p> <p>P3-06, Section 4.4.5, Section 8.2</p>

P4 - 08	PKEY	Digital Keypad Input of Servo Drive	Communication Addr.: 0408H
	<p>Default: N/A</p> <p>Applicable Control Mode: ALL</p> <p>Unit: N/A</p> <p>Range: N/A</p>		<p>Related Section: N/A</p>

Chapter 7 Servo Parameters | ASDA-A&A+ Series

P4 - 09★	MOT	Output Status Display	Communication Addr.: 0409H
-----------------	------------	------------------------------	-----------------------------------

Default: 0

Related Section:

Applicable Control Mode: ALL

Section 4.4.6

Unit: N/A

Range: 0~0x1F

Settings:

External Control: Display the status of DO output signal

Communication Control: Read the status of output signal

The status of DO signal, please refer to P2-18 ~ P2-22.

P4 - 10▲	CEN	Adjustment Function	Communication Addr.: 040AH
-----------------	------------	----------------------------	-----------------------------------

Default: 0

Related Section: N/A

Applicable Control Mode: ALL

Unit: N/A

Range: 0~6

Settings:

0: Reserved

1: Execute analog speed input drift adjustment

2: Execute analog torque input drift adjustment

3: Execute current detector (V phase) drift adjustment

4: Execute current detector (W phase) drift adjustment

5: Execute drift adjustment of the above 1~4

6: Execute IGBT NTC calibration

This adjustment function is enabled after parameter P2-08 is set to 20.

When executing any adjustment, the external wiring connected to analog speed or torque must be removed and the servo system should be off (Servo off).

Chapter 7 Servo Parameters | ASDA-A&A+ Series

P4 - 11	SOF1	Analog Speed Input Drift Adjustment 1	Communication Addr.: 040BH
----------------	-------------	--	-----------------------------------

Default: Factory setting

Related Section: N/A

Applicable Control Mode: ALL

Unit: N/A

Range: 0~32767

Settings:

Manual Adjustment Operation:

Set parameter P2-08 to 22 and then change this parameter. This is an auxiliary adjusting function, although this parameter allows the users can execute manual adjustment, we still do not recommend users to change the default setting manually.

Auto Adjustment Operation:

Set parameter P2-08 to 20 first and then set parameter P4-10 to 1. When executing this auto adjustment, please short the internal circuit of the analog input voltage first or connecting to a 0V output of the external controller in advance and make sure that the status of the servo drive is "Servo Off".



-
- 1) When P2-08 is set to 10, users cannot reset this parameter.

P4 - 12	SOF2	Analog Speed Input Drift Adjustment 2	Communication Addr.: 040CH
----------------	-------------	--	-----------------------------------

Default: Factory setting

Related Section: N/A

Applicable Control Mode: ALL

Unit: N/A

Range: 0~32767

Settings:

Please see P4-11 for explanation.



-
- 1) When P2-08 is set to 10, users cannot reset this parameter.

Chapter 7 Servo Parameters | ASDA-A&A+ Series

P4 - 13**TOF1****Analog Torque Drift Adjustment 1****Communication Addr.: 040DH**

Default: Factory setting

Related Section: N/A

Applicable Control Mode: ALL

Unit: N/A

Range: 0~32767

Settings:

Manual Adjustment Operation:

Set parameter P2-08 to 22 and then change this parameter. This is an auxiliary adjusting function, although this parameter allows the users can execute manual adjustment, we still do not recommend users to change the default setting manually.

Auto Adjustment Operation:

Set parameter P2-08 to 20 first and then set parameter P4-10 to 2. When executing this auto adjustment, please short the internal circuit of the analog input voltage first or connecting to a 0V output of the external controller in advance and make sure that the status of the servo drive is "Servo Off".

**NOTE**

-
- 1) When P2-08 is set to 10, users cannot reset this parameter.

P4 - 14**TOF2****Analog Torque Drift Adjustment 2****Communication Addr.: 040EH**

Default: Factory setting

Related Section: N/A

Applicable Control Mode: ALL

Unit: N/A

Range: 0~32767

Settings:

Please see P4-13 for explanation.

**NOTE**

-
- 1) When P2-08 is set to 10, users cannot reset this parameter.

Chapter 7 Servo Parameters | ASDA-A&A+ Series

P4 - 15	COF1	Current Detector Drift Adjustment (V1 phase)	Communication Addr.: 040FH
----------------	-------------	---	-----------------------------------

Default: Factory setting

Related Section: N/A

Applicable Control Mode: ALL

Unit: N/A

Range: 0~32767

Settings:

Manual Adjustment Operation:

Set parameter P2-08 to 22 and then change this parameter. This is an auxiliary adjusting function, although this parameter allows the users can execute manual adjustment, we still do not recommend users to change the default setting manually.

Auto Adjustment Operation:

Set parameter P2-08 to 20 first and then set parameter P4-10 to 3. When executing this auto adjustment, please short the internal circuit of the analog input voltage first or connecting to a 0V output of the external controller in advance and make sure that the status of the servo drive is "Servo Off" and the servo motor has stopped.



-
- 1) When P2-08 is set to 10, users cannot reset this parameter.

P4 - 16	COF2	Current Detector Drift Adjustment (V2 phase)	Communication Addr.: 0410H
----------------	-------------	---	-----------------------------------

Default: Factory setting

Related Section: N/A

Applicable Control Mode: ALL

Unit: N/A

Range: 0~32767

Settings:

Please see P4-15 for explanation.



-
- 1) When P2-08 is set to 10, users cannot reset this parameter.

Chapter 7 Servo Parameters | ASDA-A&A+ Series

P4 - 17**COF3****Current Detector Drift Adjustment (W1 phase)****Communication Addr.: 0411H**

Default: Factory setting

Related Section: N/A

Applicable Control Mode: ALL

Unit: N/A

Range: 0~32767

Settings:

Manual Adjustment Operation:

Set parameter P2-08 to 22 and then change this parameter. This is an auxiliary adjusting function, although this parameter allows the users can execute manual adjustment, we still do not recommend users to change the default setting manually.

Auto Adjustment Operation:

Set parameter P2-08 to 20 first and then set parameter P4-10 to 4. When executing this auto adjustment, please short the internal circuit of the analog input voltage first or connecting to a 0V output of the external controller in advance and make sure that the status of the servo drive is "Servo Off" and the servo motor has stopped.

**NOTE**

-
- 1) When P2-08 is set to 10, users cannot reset this parameter.

P4 - 18**COF4****Current Detector Drift Adjustment (W2 phase)****Communication Addr.: 0412H**

Default: Factory setting

Related Section: N/A

Applicable Control Mode: ALL

Unit: N/A

Range: 0~32767

Settings:

Please see P4-15 for explanation.

**NOTE**

-
- 1) When P2-08 is set to 10, users cannot reset this parameter.

Chapter 7 Servo Parameters | ASDA-A&A+ Series

P4 - 19	TIGB	IGBT NTC Calibration	Communication Addr.: 0413H
----------------	-------------	-----------------------------	-----------------------------------

Default: Factory setting

Related Section: N/A

Applicable Control Mode: ALL

Unit: N/A

Range: 1~7

Settings:

Manual Adjustment Operation:

Set parameter P2-08 to 22 and then change this parameter. This is an auxiliary adjusting function, although this parameter allows the users can execute manual adjustment, we still do not recommend users to change the default setting manually.

Auto Adjustment Operation:

Set parameter P2-08 to 20 first and then set parameter P4-10 to 6. When executing this auto adjustment, please ensure to cool the servo drive to 25^oC.



-
- 1) When P2-08 is set to 10, users cannot reset this parameter.

P4 - 20	DOF1	Analog Monitor Output Drift Adjustment (CH1)	Communication Addr.: 0414H
----------------	-------------	---	-----------------------------------

Default: Factory setting

Related Section:

Applicable Control Mode: ALL

Section 6.4.4

Unit: mV

Range: -800~800

Settings:

When P2-08 is set to 10, users cannot reset this parameter.

P4 - 21	DOF2	Analog Monitor Output Drift Adjustment (CH2)	Communication Addr.: 0415H
----------------	-------------	---	-----------------------------------

Default: Factory setting

Related Section: N/A

Applicable Control Mode: ALL

Section 6.4.4

Unit: mV

Range: -800~800

Settings:

When P2-08 is set to 10, users cannot reset this parameter.

Chapter 7 Servo Parameters | ASDA-A&A+ Series

P4 - 22	SAO	Analog Speed Input Offset	Communication Addr.: 0416H
----------------	------------	----------------------------------	-----------------------------------

Default: 0

Related Section: N/A

Applicable Control Mode: S

Unit: mV

Range: -5000~5000

Settings:

In speed mode, the users can use this parameter to adjust analog speed input offset value manually. Before using this function, please short the internal circuit first or connecting to a 0V output of the external controller in advance, and then use this parameter to adjust analog speed input offset value.

P4 - 23	TAO	Analog Torque Input Offset	Communication Addr.: 0417H
----------------	------------	-----------------------------------	-----------------------------------

Default: 0

Related Section: N/A

Applicable Control Mode: T

Unit: mV

Range: -5000~5000

Settings:

In torque mode, the users can use this parameter to adjust analog torque input offset value manually. Before using this function, please short the internal circuit first or connecting to a 0V output of the external controller in advance, and then use this parameter to adjust analog torque input offset value.

P4 - 24	Reserved	Communication Addr.: 0418H
----------------	-----------------	-----------------------------------

P4 - 25	Reserved	Communication Addr.: 0419H
----------------	-----------------	-----------------------------------

P4 - 26	Reserved	Communication Addr.: 041AH
----------------	-----------------	-----------------------------------

Chapter 7 Servo Parameters | ASDA-A&A+ Series

Table 7.A Input Function Definition

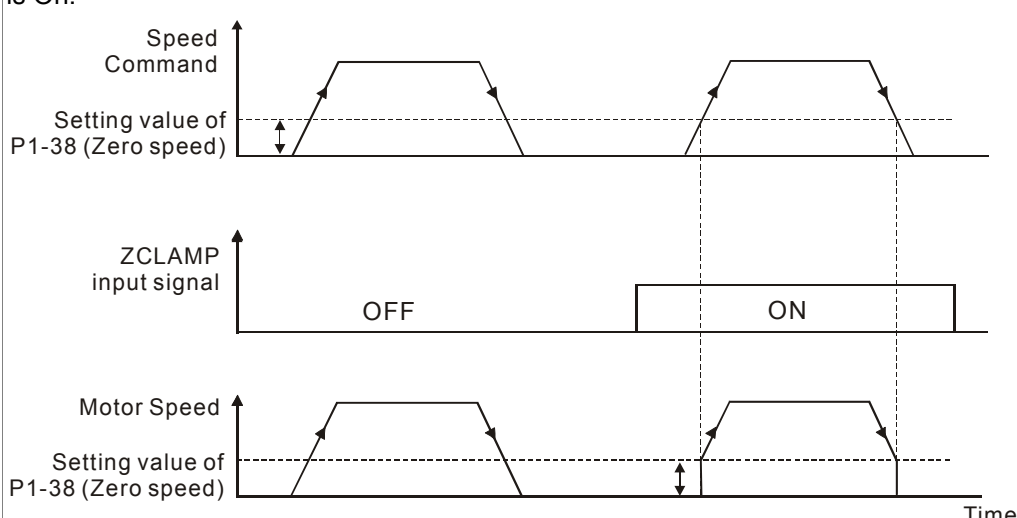
Sign	Setting Value	Digital Input Function Description
SON	01	Servo On. Switch servo to "Servo Ready". Check parameter P2-51.
ARST	02	Alarm Reset. A number of Faults (Alarms) can be cleared by activating ARST.
GAINUP	03	Gain switching in speed and position mode. When GAINUP is activated (P2-27 is set to 1), the gain is switched to the gain multiplied by fluctuation
CCLR	04	Pulse clear (see P2-50). When CCLR is activated, the parameter P2-50 Pulse Deviation Clear Mode is executed. 0: Clear position pulse deviation number (available in Pt and Pr mode only) 1: Clear motor feedback pulse and rotation number (available in Pt and Pr mode only) 2: Clear remaining position pulses and interrupt the motor operation (available Pr mode only). 3: Clear remaining position pulses and interrupt the motor operation. After the motor is stopped, activate TPOS signal (available Pr mode only).
ZCLAMP	05	Zero speed CLAMP. When this signal is On and the motor speed value is below the setting value of P1-38, it is used to lock the motor in the instant position while ZCLAMP is On. 
CMDINV	06	Command input reverse control. When the drive is in Pr, Speed and Torque mode, and CMDINV is activated, the motor is in reverse rotation.
HOLD	07	Position command pause (Internal position control only). When the drive is in Pr mode and HOLD is activated, the motor will pause.
CTRG	08	Command triggered (available in Pr mode only). When the drive is in Pr mode and CTRG is activated, the drive will command the motor to move the stored position which correspond the POS 0, POS 1, POS 2 settings. Activation is triggered on the rising edge of the pulse. The next internal position command will be triggered after the DO ZSPD (At Zero speed) signal is activated (ZSPD=1).
TRQLM	09	Torque limit enabled. When the drive is in speed and position mode, and TRQLM is activated, it indicates the torque limit command is valid. The torque limit command source is internal parameter or analog voltage.
SPDLM	10	Speed limit enabled. When the drive is in torque mode and TRQLM is activated, it indicates the speed limit command is valid. The speed limit command source is internal parameter or analog voltage.

Chapter 7 Servo Parameters | ASDA-A&A+ Series

Sign	Setting Value	Digital Input Function Description							
POS0	11	Position command selection 0 ~ 2 When the Pr mode is selected, the 8 stored positions are programmed via a combination of the POS 0, POS 1, and POS 2 commands.							
		Command No.	POS2	POS1	POS0	CTRG	Parameter		
		P1	OFF	OFF	OFF	↑	P1-15 P1-16		
		P2	OFF	OFF	ON	↑	P1-17 P1-18		
		P3	OFF	ON	OFF	↑	P1-19 P1-20		
		P4	OFF	ON	ON	↑	P1-21 P1-22		
		P5	ON	OFF	OFF	↑	P1-23 P1-24		
		P6	ON	OFF	ON	↑	P1-25 P1-26		
POS1	12	P7	ON	ON	OFF	↑	P1-27 P1-28		
		P8	ON	ON	ON	↑	P1-29 P1-30		
POS2	13								
SPD0	14	Speed command selection 0 ~ 1							
		Command No.	DI signal of CN1		Command Source		Content	Range	
			SPD1	SPD0	Mode	S	External analog command	Voltage between V-REF and GND	+/- 10 V
		S1	OFF	OFF		Sz	None	Speed command is 0	0
SPD1	15	S2	OFF	ON	Internal parameter		P1-09	+/- 5000 r/min	
		S3	ON	OFF			P1-10	+/- 5000 r/min	
		S4	ON	ON			P1-11	+/- 5000 r/min	
TCM0	16	Torque command selection 0 ~ 1							
		Command No.	DI signal of CN1		Command Source		Content	Range	
			TCM1	TCM0	Mode	T	Analog command	Voltage between V-REF and GND	+/- 10 V
		T1	OFF	OFF		Tz	None	Torque command is 0	0
TCM1	17	T2	OFF	ON	Internal parameter		P1-12	+/- 300 %	
		T3	ON	OFF			P1-13	+/- 300 %	
		T4	ON	ON			P1-14	+/- 300 %	
S-P	18	Speed / Position mode switching (OFF: Speed, ON: Position) (see section 6.5)							

Chapter 7 Servo Parameters | ASDA-A&A+ Series

Sign	Setting Value	Digital Input Function Description					
S-T	19	Speed / Torque mode switching (OFF: Speed, ON: Torque) (see section 6.5)					
T-P	20	Torque / Position mode switching (OFF: Torque, ON: Position) (see section 6.5)					
EMGS	21	Emergency stop. It should be contact "b" and normally ON or a fault (ALE13) will display.					
CWL	22	Reverse inhibit limit. It should be contact "b" and normally ON or a fault (ALE14) will display.					
CCWL	23	Forward inhibit limit. It should be contact "b" and normally ON or a fault (ALE15) will display.					
ORGP	24	Reference "Home" sensor. When ORGP is activated, the drive will command the motor to start to search the reference "Home" sensor. [see P1-47]					
TLLM	25	Torque limit - Reverse operation (Torque limit function is valid only when P1-02 is enabled)					
TRLM	26	Torque limit - Forward operation (Torque limit function is valid only when P1-02 is enabled)					
SHOM	27	Move to "Home". When SHOM is activated, the drive will command the motor to move to "Home". [see P1-47]					
INDEX0	28	Feed step selection input 0 (bit 0)	When the drive is in Pr mode, if users set P1-33 to 2, 3 and 4 (Feed step control mode), feed step control function are provided (1~32 steps). [see section 12.6 Feed Step Control]				
INDEX1	29	Feed step selection input 1 (bit 1)					
INDEX2	30	Feed step selection input 2 (bit 2)					
INDEX3	31	Feed step selection input 3 (bit 3)					
INDEX4	32	Feed step selection input 4 (bit 4)					
MD0	33	Feed step mode input 0 (bit 0)	Mode function:				
MD1	34	Feed step mode input 1 (bit 1)	OFF	1	OFF	OFF	Torque decrease
MDP0	35	Manually continuous operation		2	OFF	ON	Homing mode
				3	ON	OFF	Feed step position mode
				4	ON	ON	Emergency stop
MDP1	36	Manually single step operation	ON		X	X	Don't care
					OFF	ON	CCW manual operation
					ON	OFF	CW manual operation
				X	X	Don't care	
JOGU	37	Forward JOG input. When JOGU is activated, the motor will JOG in forward direction. [see P4-05]					
JOGD	38	Reverse JOG input. When JOGD is activated, the motor will JOG in reverse direction. [see P4-05]					
STEPU	39	Step up input. When STEPUP is activated, the motor will run to next position.	Available when the drive is in Pr mode and users must set P1-33 to 5 and 6. (Internal auto running mode) [see section 12-7 Internal Auto Running Mode]				

Chapter 7 Servo Parameters | ASDA-A&A+ Series

Sign	Setting Value	Digital Input Function Description																
STEPD	40	Step down input. When STEPD is activated, the motor will run to previous position.	Available when the drive is in Pr mode and users must set P1-33 to 5 and 6. (Internal auto running mode) [see section 12-7 Internal Auto Running Mode]															
STEPB	41	Step back input. When STEPB is activated, the motor will return to first position.																
AUTOR	42	Auto run input. When AUTOR is activated, the motor will run automatically according to internal position command. For interval time setting (Timer 0 ~ 7), please see parameter P2-52 to P2-59. If the timer is not set, the internal position command without setting timer will be passed over and not executed. The motor will run according to the next internal position command.																
GNUM0	43	Electronic gear ratio (Numerator) selection 0 [see P2-60 ~ P2-62]																
GNUM1	44	Electronic gear ratio (Numerator) selection 1 [see P2-60 ~ P2-62] GNUM0, GNUM1 																
INHP	45	Pulse inhibit input. When the drive is in position mode, if INHP is activated, the external pulse input command is not valid.																
STF	46	Enable motor forward operation. In speed mode, it is used to enable the motor forward operation.																
STB	47	Enable motor reverse operation. In speed mode, it is used to enable the motor reverse operation. <table border="1"> <thead> <tr> <th>STF</th> <th>STB</th> <th>Explanation</th> </tr> </thead> <tbody> <tr> <td>1</td> <td>0</td> <td>Forward operation of speed command (CCWL)</td> </tr> <tr> <td>1</td> <td>1</td> <td>Stop</td> </tr> <tr> <td>0</td> <td>0</td> <td>Stop</td> </tr> <tr> <td>0</td> <td>1</td> <td>Reverse operation of speed command (CWL)</td> </tr> </tbody> </table> 0: indicates OFF (Normally Open); 1: indicates ON (Normally Closed) Please note that never use DI STF and STB with DI SPD0 and SPD1 simultaneously.		STF	STB	Explanation	1	0	Forward operation of speed command (CCWL)	1	1	Stop	0	0	Stop	0	1	Reverse operation of speed command (CWL)
STF	STB	Explanation																
1	0	Forward operation of speed command (CCWL)																
1	1	Stop																
0	0	Stop																
0	1	Reverse operation of speed command (CWL)																

NOTE

- 1) 11~17: Single control mode, 18~20: Dual control mode
- 2) When P2-10 to P2-17 is set to 0, it indicates input function is disabled.

Chapter 7 Servo Parameters | ASDA-A&A+ Series

Table 7.B Output Function Definition

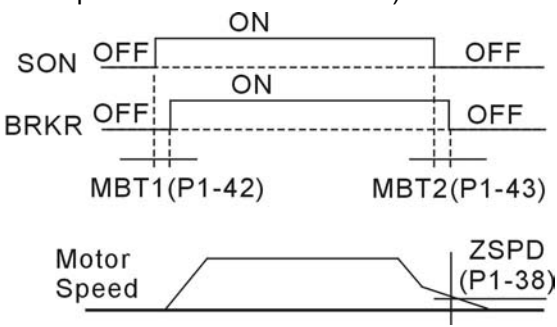
Sign	Setting Value	Digital Output Function Description
SRDY	01	Servo ready. SRDY is activated when the servo drive is ready to run. All fault and alarm conditions, if present, have been cleared.
SON	02	Servo On. SON is activated when control power is applied the servo drive. The drive may or may not be ready to run as a fault / alarm condition may exist. Servo ON (SON) is "ON" with control power applied to the servo drive, there may be a fault condition or not. The servo is not ready to run. Servo ready (SRDY) is "ON" where the servo is ready to run, NO fault / alarm exists. (P2-51 should turn servo ready SRDY off / on)
ZSPD	03	At Zero speed. ZSPD is activated when the drive senses the motor is equal to or below the Zero Speed Range setting as defined in parameter P1-38. For Example, at default ZSPD will be activated when the drive detects the motor rotating at speed at or below 10 r/min. ZSPD will remain activated until the motor speed increases above 10 r/min.
TSPD	04	At Speed reached. TSPD is activated once the drive has detected the motor has reached the Target Motor Speed setting as defined in parameter P1-39. TSPD will remain activated until the motor speed drops below the Target Motor Speed.
TPOS	05	At Positioning completed. When the drive is in Pt mode, TPOS will be activated when the position error is equal and below the setting value of P1-54. When the drive is in Pr mode, TPOS will be activated when the drive detects that the position of the motor is in a -P1-54 to +P1-54 band of the target position. For Example, at factory default TPOS will activate once the motor is in -99 pulses range of the target position, then deactivate after it reaches +99 pulses range of the desired position.
TQL	06	At Torques limit. TQL is activated when the drive has detected that the motor has reached the torques limits set by either the parameters P1-12 ~ P1-14 of via an external analog voltage.
ALRM	07	Servo alarm (Servo fault) activated. ALRM is activated when the drive has detected a fault condition. (However, when Reverse limit error, Forward limit error, Emergency stop, Serial communication error, and Undervoltage these fault occur, WARN is activated first.)
BRKR	08	Electromagnetic brake control. BRKR is activated (Actuation of motor brake). (Please refer to parameters P1-42 ~ P1-43) 
HOME	09	Homing completed. HOME is activated when the servo drive has detected that the "HOME" sensor (Digital Input 24) has been detected and the home conditions set in parameters P1-47, P1-50, and P1-51 have been satisfied.

Chapter 7 Servo Parameters | ASDA-A&A+ Series

Sign	Setting Value	Digital Output Function Description
OLW	10	<p>Output overload warning. OLW is activated when the servo drive has detected that the motor has reached the output overload time set by parameter P1-56.</p> <p>t_{OL} = Permissible Time for Overload x setting value of P1-56</p> <p>When overload accumulated time (continuously overload time) exceeds the value of t_{OL}, the overload warning signal will output, i.e. DO signal, OLW will be ON. However, if the accumulated overload time (continuous overload time) exceeds the permissible time for overload, the overload alarm (ALE06) will occur.</p> <p>For example:</p> <p>If the setting value of parameter P1-56 (Output Overload Warning Time) is 60%, when the permissible time for overload exceeds 8 seconds at 200% rated output, the overload fault (ALE06) will be detected and shown on the LED display.</p> <p>At this time, $t_{OL} = 8 \times 60\% = 4.8$ seconds</p> <p>Result:</p> <p>When the drive output is at 200% rated output and the drive is continuously overloaded for 4.8 seconds, the overload warning signal will be ON (DO code is 10, i.e. DO signal OLW will be activated) and the overload warning (ALE23) will be displayed. If the drive is continuously overloaded for 8 seconds, the overload alarm will be detected and shown on the LED display (ALE06). Then, Servo Fault signal will be ON (DO signal ALRM will be activated).</p>
WARN	11	Servo warning activated. WARN is activated when the drive has detected Reverse limit error, Forward limit error, Emergency stop, Serial communication error, and Undervoltage these fault conditions.
CMDOK	12	Internal position command completed. CMDOK is activated when the servo drive has detected that the internal position command has been completed or stopped after the delay time which is set by the parameter P1-62 has elapsed.

 **NOTE**

- 1) When P2-18 to P2-22 is set to 0, it indicates output function is disabled.

Chapter 7 Servo Parameters | ASDA-A&A+ Series

This page intentionally left blank.

Chapter 8 MODBUS Communications

8.1 Communication Hardware Interface

The ASDA-A and ASDA-A+ series servo drives have three modes of communication: RS-232, RS-485, and RS-422. All aspects of control, operation and monitoring as well as programming of the controller can be achieved via communication. However, only one communication mode can be used at a time. Users can select the desired communication mode via parameter P3-05.

Please refer to the following sections for connections and limitations.

RS-232

■ Configuration

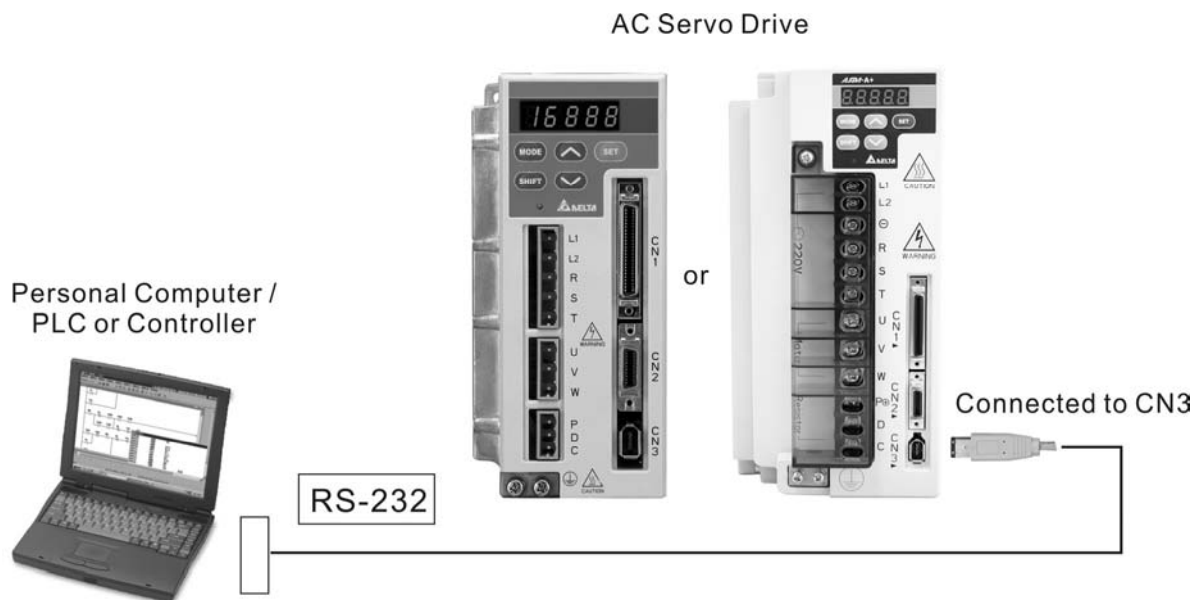

■ Cable Connection

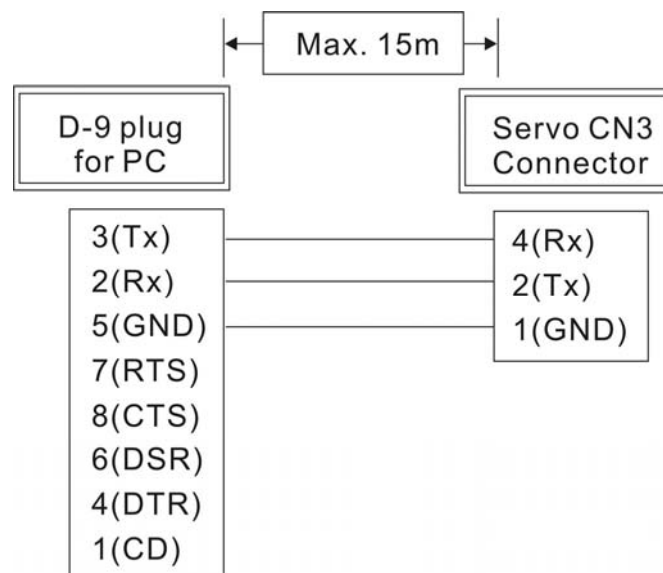

Chapter 8 MODBUS Communications | ASDA-A&A+ Series

NOTE

- 1) Recommended maximum cable length is 15m (50ft.). Please note, RFI / EME noise should be kept to a minimum, communication cable should be kept apart from high voltage wires. If a transmission speed of 38400 bps or greater is required, the maximum length of the communication cable is 3m (9.84ft.) which will ensure the correct and desired baud rate.
- 2) The number shown in the pervious figure indicates the terminal number of each connector.

RS-485, RS-422

■ Configuration

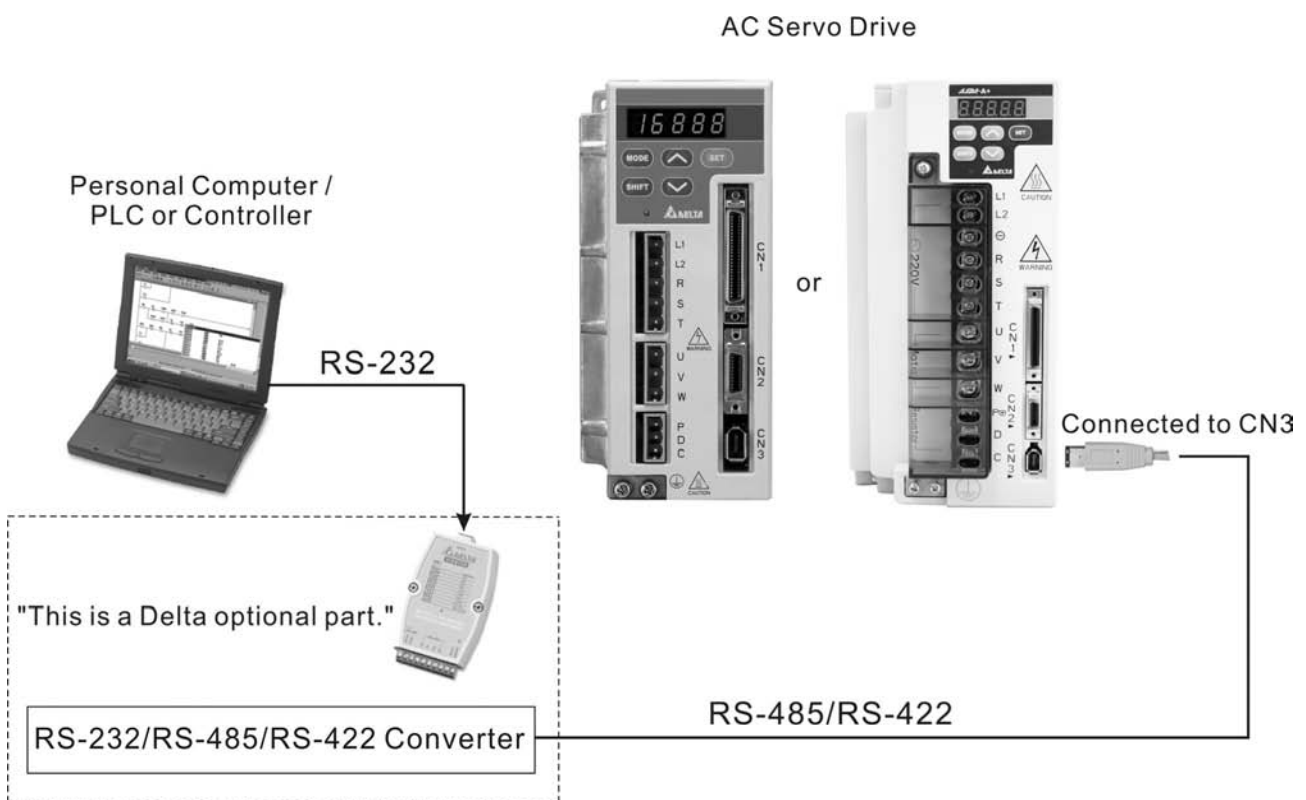

Chapter 8 MODBUS Communications | ASDA-A&A+ Series

■ **Cable Connection**

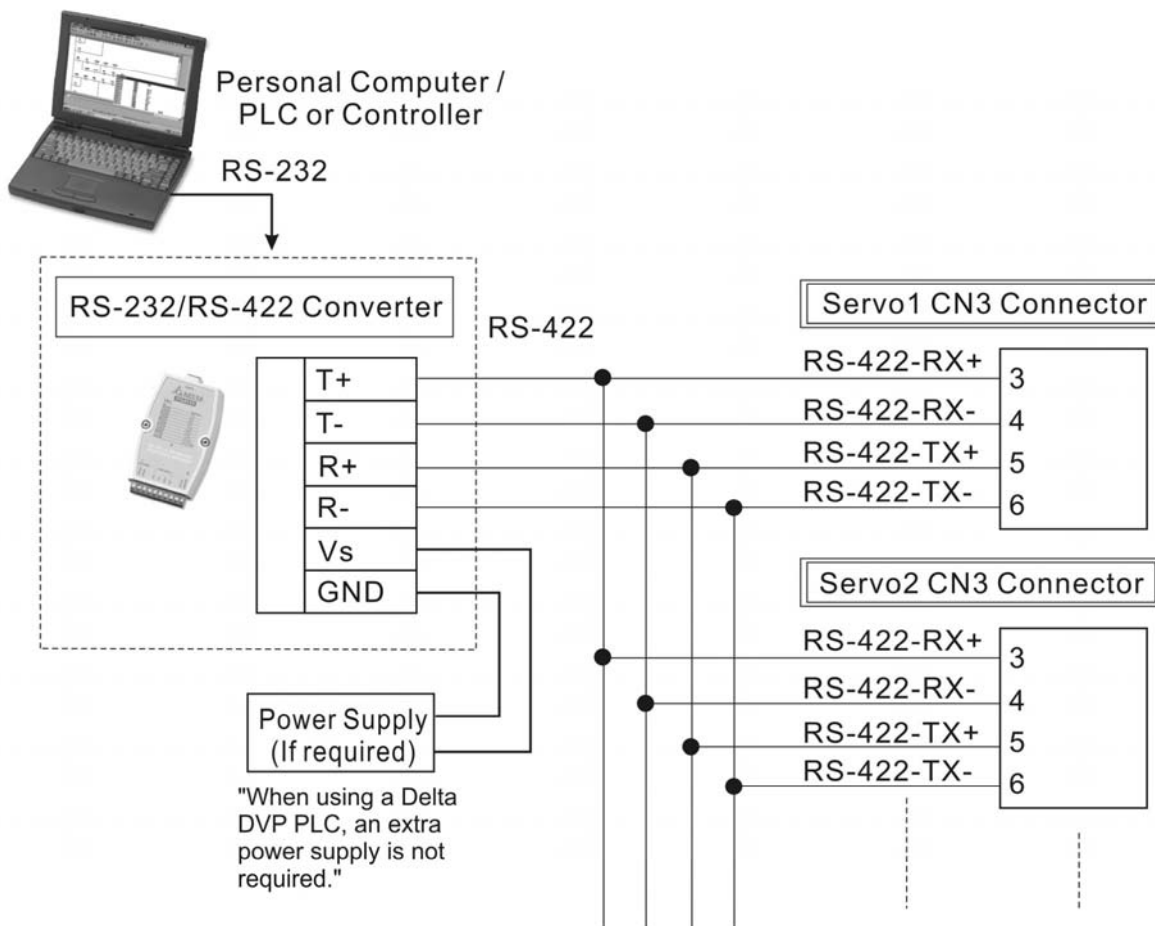
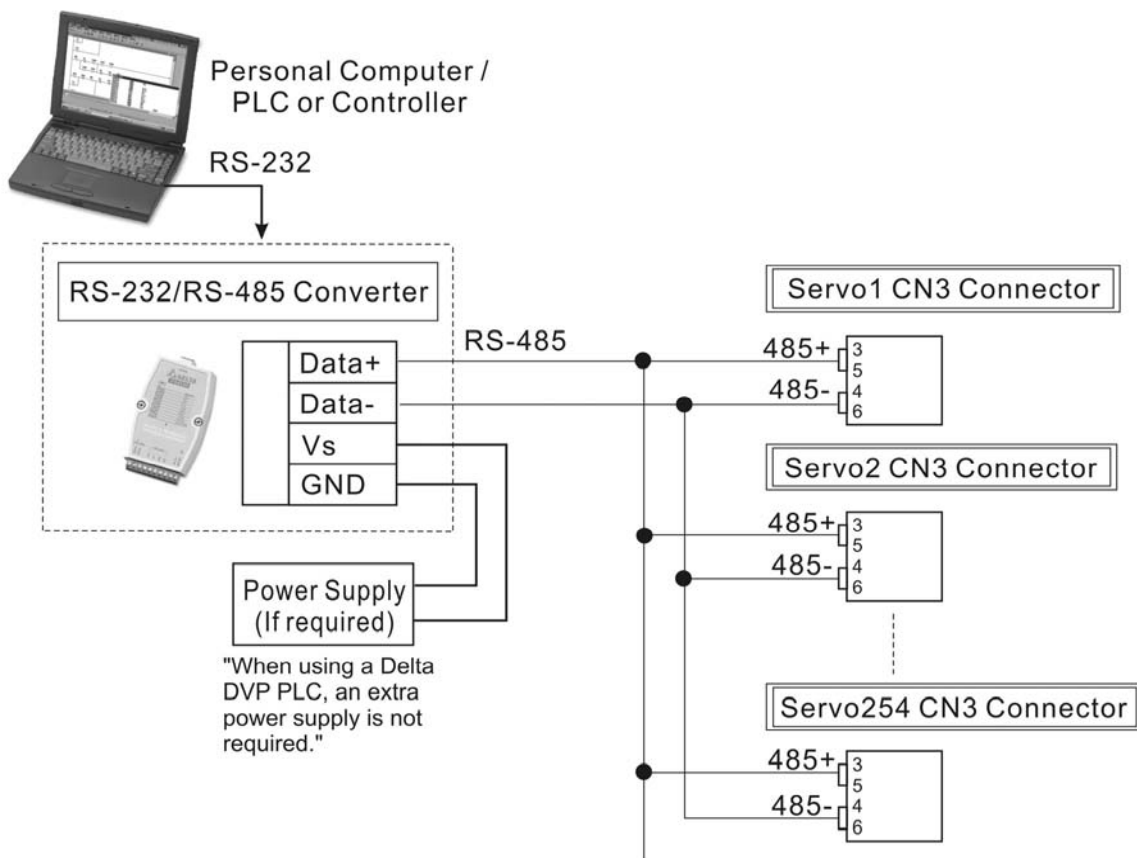

Chapter 8 MODBUS Communications | ASDA-A&A+ Series



- 1) The maximum cable length is 100m (39.37inches) when the servo drive is installed in a location where there are only a few interferences. Please note, RFI / EME noise should be kept to a minimum, communication cable should kept apart from high voltage wires. If a transmission speed of 38400 bps or greater is required, the maximum length of the communication cable is 15m (50ft.) which will ensure the correct and desired baud rate.
- 2) The number shown in the pervious figure indicates the terminal number of each connector.
- 3) The power supply should provide a +12V and higher DC voltage.
- 4) Please use a REPEATER if more than 32 synchronous axes are required.
- 5) For the terminal identification of CN3, please refer to Section 3.5.

Chapter 8 MODBUS Communications | ASDA-A&A+ Series

8.2 Communication Parameter Settings

The following describes the communication addresses for the communication parameters.

For communication parameters, please refer to the Chapter 7. Communication Addresses 0301, 0302, and 0305 have to be set identically for all the drives and devices to communicate correctly.

0300H Communication Address Setting	Default: 1 Range: 1~254
---	----------------------------

 If the AC servo drive is controlled by RS-232/485/422 communication, each drive (or device) must be uniquely identified and addressed between 1 and 254. Access to program this number is via parameter P3-00.

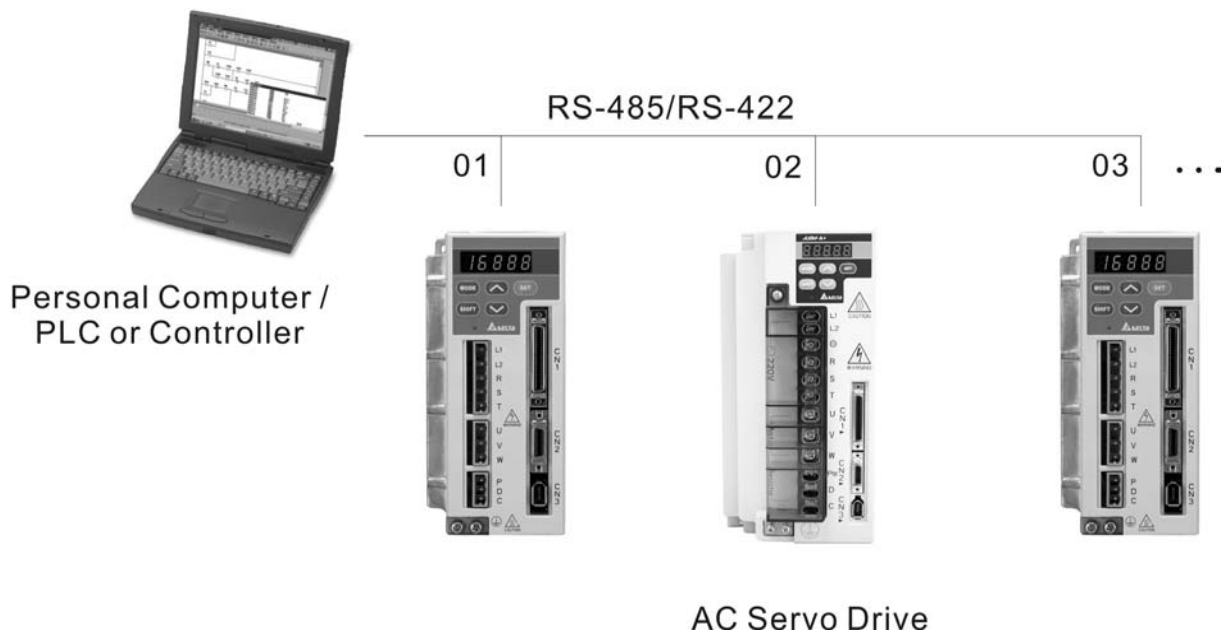

0301H Transmission Speed	Default: 1 Range: 0~5 Settings: 0: Baud rate 4800 (data transmission speed: bits / second) 1: Baud rate 9600 (data transmission speed: bits / second) 2: Baud rate 19200 (data transmission speed: bits / second) 3: Baud rate 38400 (data transmission speed: bits / second) 4: Baud rate 57600 (data transmission speed: bits / second) 5: Baud rate 115200 (data transmission speed: bits / second)
--------------------------------	--

 This parameter is used to set the desired transmission speed between the computer and AC servo drive. Users can set this parameter and control transmission speed to reach the maximum baud rate of 115200 bps.

Chapter 8 MODBUS Communications | ASDA-A&A+ Series

0302H Communication Protocol	Default: 0 Range: 0~8 Settings: 0: Modbus ASCII mode, <7,N,2> 1: Modbus ASCII mode, <7,E,1 > 2: Modbus ASCII mode, <7,O,1> 3: Modbus ASCII mode, <8,N,2 > 4: Modbus ASCII mode, <8,E,1> 5: Modbus ASCII mode, <8,O,1> 6: Modbus RTU mode, <8,N,2> 7: Modbus RTU mode, <8,E,1> 8: Modbus RTU mode, <8,O,1>
---------------------------------	--

 This parameter is used to set the communication protocol. The alphanumeric characters represent the following: 7 or 8 is the number of data bits; N, E or O refer to the parity bit, Non, Even or Odd; the 1 or 2 is the numbers of stop bits.

0303H Transmission Fault Treatment	Default: 0 Range: 0~1 Settings: 0: Display fault and continue operating 1: Display fault and stop operating
---------------------------------------	---

 This parameter is used to determine the operating sequence once a communication fault has been detected. If '1' is selected the drive will stop operating upon detection the communication fault. The mode of stopping is set by parameter P1-32.

0304H Communication Time Out Detection	Watch Dog Timer (It is not recommended to change the factory default setting if not necessary) Default: 0 Range: 0~20 sec. The factory default setting is set to 0 and it indicates this function is disabled.
---	---

 When this parameter is set to any value over 0, it indicates that the timer is enabled. The value set in this parameter is the communication time and the communication time out detection should be completed within the time. Otherwise, a communication error will occur.



 For example, if the value set in this parameter is 5, it indicates that the communication time out detection will be activated once in five seconds or a communication error will occur.

0305H Communication Mode	Communication selection: Default: 0 Range: 0~2 Settings: 0: RS-232 1: RS-422 2: RS-485
-----------------------------	--

 Multiple communication modes RS232, RS-485, RS-422 cannot be used within one communication ring.

Chapter 8 MODBUS Communications | ASDA-A&A+ Series

0306H Digital Input Communication Function	Digital Input Contact Control: Default: 0 Range: 0~FFFF (hexadecimal number)
---	--



-  The setting of this parameter determines how the Digital Inputs (DI) accept commands and signals.
-  Input commands or signals through the DI can be either from an external source, through the CN 1 interface connector, or via communication, (RS-232, RS-485, RS-422). If the Digital Input Contact Control parameter for the DI 1 ~ 8 is set to "0", command is external, and via CN1; if it is set to "1" (decimal number) the DI signal is via communication. Each of the eight Digital Inputs are accessed individually and can be set independently of each other. They can be programmed either via the drive's keypad or via communication and computer UI. If they are programmed via the keypad a hexadecimal number is entered; if programmed via communication or UI a decimal or hexadecimal number can be used. In both methods of programming, a single number is used for all eight Digital Inputs. The following example shows how each DI is addressed and converted to a single decimal or hexadecimal number.
-  The eight Digital Inputs are noted from the right, DI 1 to left, DI 8 with their desired input command or signal method, 0 or 1. Once all eight Digital Inputs have been noted this binary number is converted to a decimal or hexadecimal number and entered into P3-06.

Bit	8	7	6	5	4	3	2	1	
Decimal value	128	64	32	16	8	4	2	1	
Input	DI8	DI7	DI6	DI5	DI4	DI3	DI2	DI1	
State	1	1	0	1	1	0	0	0	= D8 Hex

(Keypad, Communication or UI)

(External CN1
Communication)

or = 216 Dec (Communication or UI only)

-  Please see Chapter 4.4.5 DI Signal Display Diagnosis Operation for display layout of the Digital Signal selection.
-  The Digital Input Control Contact parameter, P3-06 also works in conjunction with the Multi Function Digital Input parameter P4-07 which has several functions.
-  The contents of P4-07 is "read only" via the drive keypad and will display the state on or off ("blank" or "|") of the eight Digital Inputs which have been set in accordance to P3-06. For Example; if P3-06 has been set to 0 (All DI is external and via the CN 1 interface) and the P4-07 display is indicating the following:

_ | | _ _ _ | (for the manual this picture should be similar to the one shown on page 4-8
(Ch 4.4.5))

The Digital Inputs 1, 5, 6, & 7 are "on" (high) and Digital Inputs 2, 3, 4, & 8 are "off" (low).

Chapter 8 MODBUS Communications | ASDA-A&A+ Series

If the contents of P4-07 is being read via communication the output will be a decimal number that will represent the "binary" display. Therefore in the previous example the decimal number being read would be 113.

However, in the communication mode the user can write to P4-07 to turn the Digital Inputs either "on" or "off". Again this achieved by sending a decimal or hexadecimal number that corresponds to the binary representation of the Digital Inputs being addressed. Therefore in the previous example 113 or 71 hex would be sent to 407H to switch on Digital Inputs 1, 5, 6, & 7. Remember, previous to this P3-06 would have been set to either 255 / FF or 113 / 71 (This sets the Digital Inputs 1, 5, 6, & 7 to communication).

0307H Communication Response Delay Time	Default: 0 Range: 0~255
--	----------------------------

-  This parameter is used to delay the communication time that servo drive respond to host controller (external controller)

Chapter 8 MODBUS Communications | ASDA-A&A+ Series

8.3 MODBUS Communication Protocol

When using RS-232/485/422 serial communication interface, each ASDA-A or ASDA-A+ series AC servo drive has a pre-assigned communication address specified by parameter "P3-00". The computer then controls each AC servo drive according to its communication address. ASDA-A and ASDA-A+ series AC servo drives can be set up to communicate on a MODBUS networks using one of the following modes: ASCII (American Standard Code for Information Interchange) or RTU (Remote Terminal Unit). Users can select the desired mode along with the serial port communication protocol in parameter "P3-02".

■ Code Description:

ASCII Mode:

Each 8-bit data is the combination of two ASCII characters. For example, a 1-byte data: 64 Hex, shown as '64' in ASCII, consists of '6' (36Hex) and '4' (34Hex).

The following table shows the available hexadecimal characters and their corresponding ASCII codes.

Character	'0'	'1'	'2'	'3'	'4'	'5'	'6'	'7'
ASCII code	30H	31H	32H	33H	34H	35H	36H	37H
Character	'8'	'9'	'A'	'B'	'C'	'D'	'E'	'F'
ASCII code	38H	39H	41H	42H	43H	44H	45H	46H

RTU Mode:

Each 8-bit data is the combination of two 4-bit hexadecimal characters. For example, a 1-byte data: 64 Hex.

■ Data Format:

10-bit character frame (For 7-bit character)

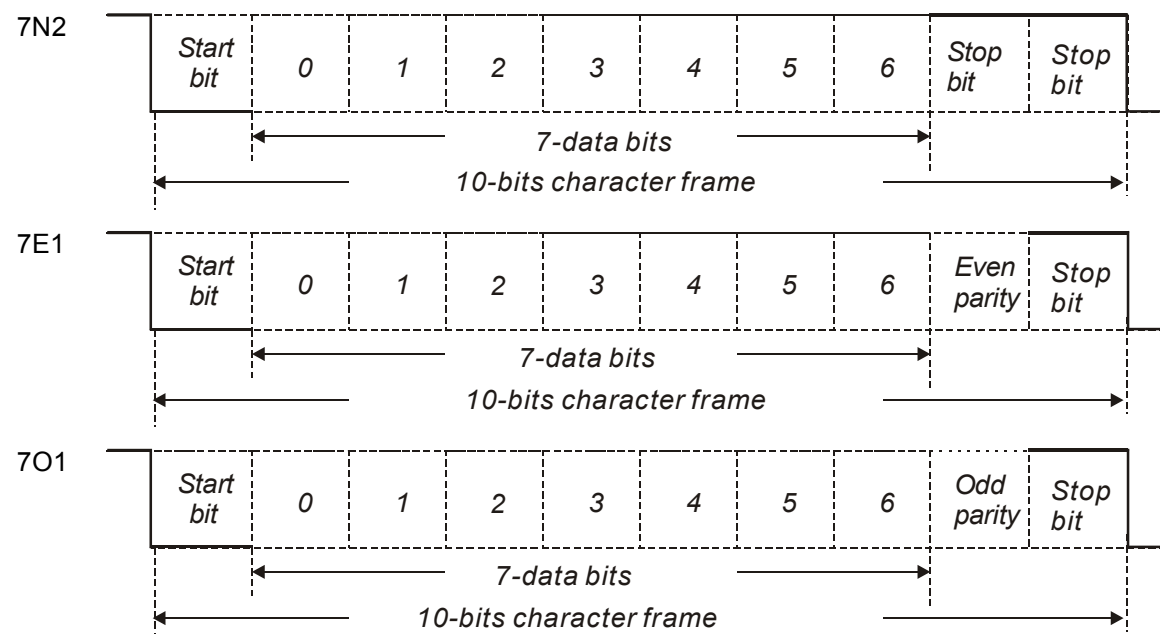

Chapter 8 MODBUS Communications | ASDA-A&A+ Series

11-bit character frame (For 8-bit character)

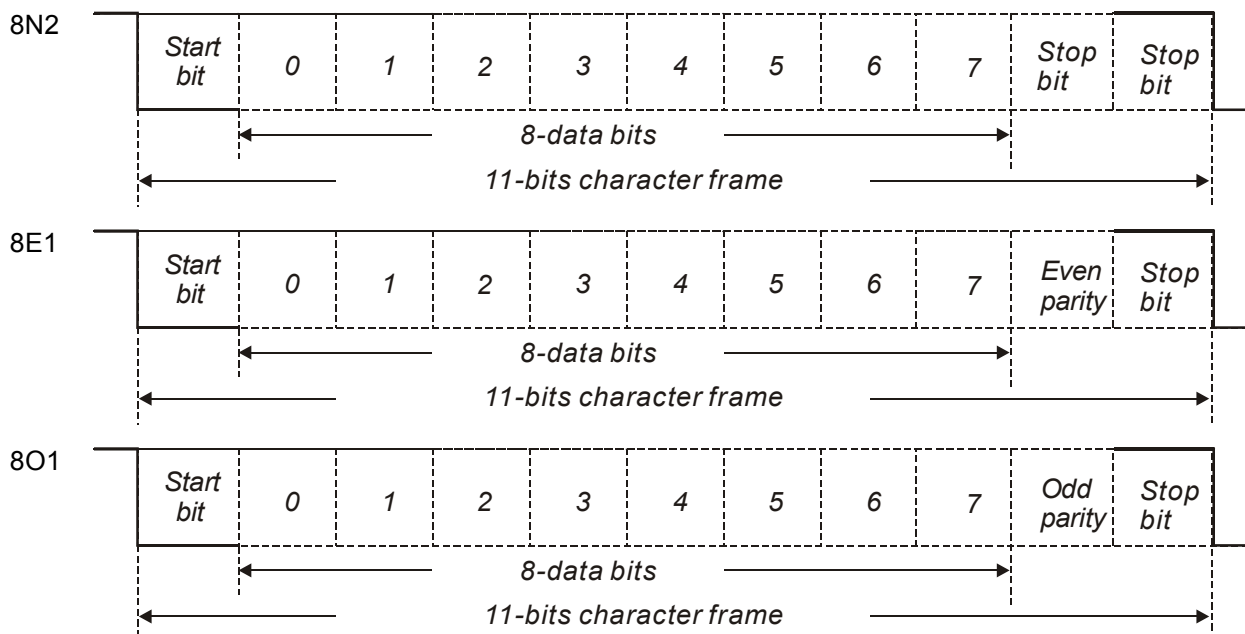

■ Communication Protocol:

ASCII Mode:

STX	Start character: ' ' (3AH)
ADR	Communication address: 1-byte consists of 2 ASCII codes
CMD	Command code: 1-byte consists of 2 ASCII codes
DATA(n-1)	Contents of data: n word = n x 2-byte consists of n x 4 ASCII codes, $n \leq 12$
.....	
DATA(0)	
LRC	Command code: 1-byte consists of 2 ASCII codes
End 1	End code 1: (0DH)(CR)
End 0	End code 0: (0AH)(LF)

RTU Mode:

STX	A silent interval of more than 10ms
ADR	Communication address: 1-byte
CMD	Command code: 1-byte
DATA(n-1)	Contents of data: n word = n x 2-byte, $n \leq 12$
.....	
DATA(0)	
CRC	Command code: 1-byte
End 1	A silent interval of more than 10ms

Chapter 8 MODBUS Communications | ASDA-A&A+ Series

STX (Communication Start)

ASCII Mode: ':' character

RTU Mode: A silent interval of more than 10ms

ADR (Communication Address)

The valid communication addresses are in the range of 1 to 254.

For example, communication to AC servo drive with address 16 decimal:

ASCII Mode: ADR='1','0' => '1'=31H , '0'=30H

RTU Mode: ADR = 10H

CMD (Command Codes) and DATA (Data Characters)

The format of data characters depends on the command code. The available command codes and examples for AC servo drive are described as follows:

Command code: 03H, read N words. The maximum value of N is 10.

For example, reading continuous 2 words from starting address 0200H of AC servo drive with address 01H.

ASCII Mode:

Command message:

STX	:
ADR	0
	1
CMD	0
	3
Starting data address	0
	2
	0
Number of data	0
	0
	0
	2
LRC Check	F
	8
End 1	(0DH)(CR)
End 0	(0AH)(LF)

Response message:

STX	:
ADR	0
	1
CMD	0
	3
Number of data (Count by byte)	0
	4
Contents of starting data address 0200H	0
	0
	B
Contents of second data address 0201H	1
	F
	4
	0
LRC Check	E
	8
End 1	(0DH)(CR)
End 0	(0AH)(LF)

Chapter 8 MODBUS Communications | ASDA-A&A+ Series**RTU Mode:****Command message:**

ADR	01H
CMD	03H
Starting data address	02H (Upper bytes)
	00H (Lower bytes)
Number of data (Count by word)	00H
	02H
CRC Check Low	C5H (Lower bytes)
CRC Check High	B3H (Upper bytes)

Response message:

ADR	01H
CMD	03H
Number of data (Count by byte)	04H
Contents of starting data address 0200H	00H (Upper bytes)
	B1H (Lower bytes)
Contents of second data address 0201H	1FH (Upper bytes)
	40H (Lower bytes)
CRC Check Low	A3H (Lower bytes)
CRC Check High	D4H (Upper bytes)

Command code: 06H, write 1 word

For example, writing 100 (0064H) to starting data address 0200H of ASDA-A and ASDA-A+ series with address 01H.

ASCII Mode:**Command message:**

STX	‘:’
ADR	‘0’
	‘1’
CMD	‘0’
	‘6’
Starting data address	‘0’
	‘2’
	‘0’
	‘0’
Content of data	‘0’
	‘0’
	‘6’
	‘4’
LRC Check	‘9’
	‘3’
End 1	(0DH)(CR)
End 0	(0AH)(LF)

Response message:

STX	‘:’
ADR	‘0’
	‘1’
CMD	‘0’
	‘6’
Starting data address	‘0’
	‘2’
	‘0’
	‘0’
Content of data	‘0’
	‘0’
	‘6’
	‘4’
LRC Check	‘9’
	‘3’
End 1	(0DH)(CR)
End 0	(0AH)(LF)

Chapter 8 MODBUS Communications | ASDA-A&A+ Series

RTU Mode:

Command message:

ADR	01H
CMD	06H
Starting data address	02H (Upper bytes)
	00H (Lower bytes)
Content of data	00H (Upper bytes)
	64H (Lower bytes)
CRC Check Low	89H (Lower bytes)
CRC Check High	99H (Upper bytes)

Response message:

ADR	01H
CMD	06H
Starting data address	02H (Upper bytes)
	00H (Lower bytes)
Content of data	00H (Upper bytes)
	64H (Lower bytes)
CRC Check Low	89H (Lower bytes)
CRC Check High	99H (Upper bytes)

LRC (ASCII Mode):

LRC (Longitudinal Redundancy Check) is calculated by summing up, module 256, the values of the bytes from ADR to last data character then calculating the hexadecimal representation of the 2's-complement negation of the sum.

For example, reading 1 word from address 0201H of the ASDA-A and ASDA-A+ series AC servo drive with address 01H.

STX	'.'
ADR	'0'
	'1'
CMD	'0'
	'3'
Starting data address	'0'
	'2'
	'0'
	'1'
Number of data	'0'
	'0'
	'0'
	'1'
LRC Check	'F'
	'8'
End 1	(0DH)(CR)
End 0	(0AH)(LF)

$01H+03H+02H+01H+00H+01H = 08H$, the 2's complement negation of 08H is F8H.

Hence, we can know that LRC CHK is 'F', '8'.

Chapter 8 MODBUS Communications | ASDA-A&A+ Series

CRC (RTU Mode):

CRC (Cyclical Redundancy Check) is calculated by the following steps:

Step 1: Load a 16-bit register (called CRC register) with FFFFH.

Step 2: Exclusive OR the first 8-bit byte of the command message with the low order byte of the 16-bit CRC register, putting the result in the CRC register.

Step 3: Extract and examine the LSB. If the LSB of CRC register is 0, shift the CRC register one bit to the right. If the LSB of CRC register is 1, shift the CRC register one bit to the right, then Exclusive OR the CRC register with the polynomial value A001H.

Step 4: Repeat step 3 until eight shifts have been performed. When this is done, a complete 8-bit byte will have been processed, then perform step 5.

Step 5: Repeat step 2 to step 4 for the next 8-bit byte of the command message.

Continue doing this until all bytes have been processed. The final contents of the CRC register are the CRC value.



NOTE

- 1) When transmitting the CRC value in the message, the upper and lower bytes of the CRC value must be swapped, i.e. the lower order byte will be transmitted first.
- 2) For example, reading 2 words from address 0101H of the AC servo drive with address 01H. The final content of the CRC register from ADR to last data character is 3794H, then the command message is shown as follows. What should be noticed is that 94H have to be transmitted before 37H.

Command Message	
ADR	01H
CMD	03H
Starting data address	01H (Upper byte)
	01H (Lower bytes)
Number of data (Count by word)	00H (Upper bytes)
	02H (Lower bytes)
CRC Check Low	94H (Lower bytes)
CRC Check High	37H (Upper bytes)

End1, End0 (Communication End)

ASCII Mode:

In ASCII mode, (0DH) stands for character '\r' (carriage return) and (0AH) stands for character '\n' (new line), they indicate communication end.

RTU Mode:

In RTU mode, a silent interval of more than 10ms indicates communication end.

Chapter 8 MODBUS Communications | ASDA-A&A+ Series

The following is an example of CRC generation using C language. The function takes two arguments:

unsigned char* data;

unsigned char length

The function returns the CRC value as a type of unsigned integer.

```
unsigned int crc_chk(unsigned char* data, unsigned char length) {
    int j;
    unsigned int reg_crc=0xFFFF;

    while( length-- ) {
        reg_crc^= *data++;
        for (j=0; j<8; j++ ) {
            if( reg_crc & 0x01 ) { /*LSB(bit 0) = 1 */
                reg_crc = (reg_crc >> 1)^0xA001;
            } else {
                reg_crc = (reg_crc>>1);
            }
        }
    }
    return reg_crc;
}
```

PC communication program example:

```
#include<stdio.h>
#include<dos.h>
#include<conio.h>
#include<process.h>
#define PORT 0x03F8      /* the address of COM 1 */
#define THR 0x0000
#define RDR 0x0000
#define BRDL 0x0000
#define IER 0x0001
#define BRDH 0x0001
#define LCR 0x0003
#define MCR 0x0004
#define LSR 0x0005
#define MSR 0x0006
unsigned char rdat[60];
/* read 2 data from address 0200H of ASD with address 1 */
unsigned char tdat[60]={':','0','1','0','3','0','2','0','0','0','0','0','2','F','8','\r','\n'};
void main() {
```

Chapter 8 MODBUS Communications | ASDA-A&A+ Series

```

int I;
outportb(PORT+MCR,0x08);          /* interrupt enable */
outportb(PORT+IER,0x01);          /* interrupt as data in */
outportb(PORT+LCR,( inportb(PORT+LCR) | 0x80 ) );
/* the BRDL/BRDH can be access as LCR.b7 == 1 */
outportb(PORT+BRDL,12);
outportb(PORT+BRDH,0x00);
outportb(PORT+LCR,0x06);          /* set prorocol
                                   <7,E,1> = 1AH,      <7,O,1> = 0AH
                                   <8,N,2> = 07H      <8,E,1> = 1BH
                                   <8,O,1> = 0BH
                                   */

for( I = 0; I<=16; I++ ) {
    while( !(inportb(PORT+LSR) & 0x20) ); /* wait until THR empty */
    outportb(PORT+THR,tdata[I]);          /* send data to THR */
}
I = 0;
while( !kbhit() ) {
    if( inportb(PORT+LSR)&0x01 ) { /* b0==1, read data ready */
        rdata[I++] = inportb(PORT+RDR); /* read data from RDR */
    }
}
}

```

Chapter 8 MODBUS Communications | ASDA-A&A+ Series

8.4 Communication Parameter Write-in and Read-out

There are following five groups for parameters:

Group 0: Monitor parameter	(example: P0-xx)
Group 1: Basic parameter	(example: P1-xx)
Group 2: Extension parameter	(example: P2-xx)
Group 3: Communication parameter	(example: P3-xx)
Group 4: Diagnosis parameter	(example: P4-xx)

For a complete listing and description of all parameters, refer to Chapter 7.

Communication write-in parameters for ASDA-A and ASDA-A+ series are including:

Group 0: P0-02 ~ P0-17 (0002H to 0017H)

Group 1: P1-00 ~ P1-62 (0100H to 0162H)

Group 2: P2-00 ~ P2-65 (0200H to 0265H)

Group 3: P3-00 ~ P3-07 (0300H to 0307H)

Group 4: P4-05 ~ P4-23 (0405H to 0423H)

NOTE

- 1) P3-01 After the new transmission speed is set, the next data will be written in new transmission speed.
- 2) P3-02 After the new communication protocol is set, the next data will be written in new communication protocol.
- 3) P4-05 JOG control of servo motor. For the description, refer to Chapter 7.
- 4) P4-06 Force output contact control. This parameter is for the users to test if DO (Digit output) is normal. User can set 1, 2, 3, 4, 5 to test DO0, DO1, DO2, DO3, DO4, respectively. After the test has been completed, please set this parameter to 0 to inform the drive that the test has been completed.
- 5) P4-10 Adjustment function selection. If user desires to change the settings of this parameter, user has to set the value of the parameter P2-08 to 20 (hexadecimal: 14H) first and then restart. After restarting, the settings of parameter P4-10 can become modified.
- 6) P4-11 ~ P4-21 These parameters are for offset adjustment. Do not change the factory default setting if not necessary. If the user desires to change the settings of these parameters, the user has to set the value of the parameter P2-08 to 22 (hexadecimal: 16H) first and then restart. After restarting, the settings of parameters P4-11 to P4-21 can become modified.

Chapter 8 MODBUS Communications | ASDA-A&A+ Series

Communication read-out parameters for ASDA-A and ASDA-A+ series are including:

Group 0: P0-00 ~ P0-17 (0000H to 0011H)

Group 1: P1-00 ~ P1-62 (0100H to 013EH)

Group 2: P2-00 ~ P2-65 (0200H to 0241H)

Group 3: P3-00 ~ P3-07 (0300H to 0307H)

Group 4: P4-00 ~ P4-23 (0400H to 0417H)

Chapter 9 Maintenance and Inspection

Delta AC servo drives are based on solid state electronics technology. Preventive maintenance is required to operate this AC servo drives in its optimal condition, and to ensure a long life. It is recommended to perform a periodic maintenance and inspection of the AC servo drive by a qualified technician. Before any maintenance and inspection, always turn off the AC input power to the unit.



➤ *Be sure to disconnect AC power and ensure that the internal capacitors have fully discharged before performing the maintenance and inspection!*

9.1 Basic Inspection

After power is in connected to the AC servo drive, the charge LED will be lit which indicates that the AC servo drive is ready.

Item	Content
General Inspection	<ul style="list-style-type: none"> ● Periodically inspect the screws of the servo drive, motor shaft, terminal block and the connection to mechanical system. Tighten screws as necessary as they may loosen due to vibration and varying temperatures. ● Ensure that oil, water, metallic particles or any foreign objects do not fall inside the servo drive, motor, control panel or ventilation slots and holes. As these will cause damage. ● Ensure the correct installation and the control panel. It should be free from airborne dust, harmful gases or liquids. ● Ensure that all wiring instructions and recommendations are followed; otherwise damage to the drive and or motor may result.
Inspection before operation (Control power is not applied)	<ul style="list-style-type: none"> ● Inspect the servo drive and servo motor to insure they were not damaged. ● To avoid an electric shock, be sure to connect the ground terminal of servo drive to the ground terminal of control panel. ● Before making any connection, wait 10 minutes for capacitors to discharge after the power is disconnected, alternatively, use an appropriate discharge device to discharge. ● Ensure that all wiring terminals are correctly insulated. ● Ensure that all wiring is correct or damage and or malfunction may result. ● Visually check to ensure that there are not any unused screws, metal strips, or any conductive or inflammable materials inside the drive. ● Never put inflammable objects on servo drive or close to the external regenerative resistor. ● Make sure control switch is OFF. ● If the electromagnetic brake is being used, ensure that it is correctly wired. ● If required, use an appropriate electrical filter to eliminate noise to the servo drive. ● Ensure that the external applied voltage to the drive is correct and matched to the controller.

Chapter 9 Maintenance and Inspection | ASDA-A&A+ Series

Item	Content
Inspection during operation (Control power is applied)	<ul style="list-style-type: none"> ● Ensure that the cables are not damaged, stressed excessively or loaded heavily. When the motor is running, pay close attention on the connection of the cables and notice that if they are damaged, frayed or over extended. ● Check for abnormal vibrations and sounds during operation. If the servo motor is vibrating or there are unusual noises while the motor is running, please contact the dealer or manufacturer for assistance. ● Ensure that all user-defined parameters are set correctly. Since the characteristics of various machinery are different, in order to avoid accident or cause damage, do not adjust the parameter abnormally and ensure the parameter setting is not an excessive value. ● Ensure to reset some parameters when the servo drive is off (Please refer to Chapter 7). Otherwise, it may result in malfunction. ● If there is no contact sound or there be any unusual noises when the relay of the servo drive is operating, please contact your distributor for assistance or contact with Delta. ● Check for abnormal conditions of the power indicators and LED display. If there is any abnormal condition of the power indicators and LED display, please contact your distributor for assistance or contact with Delta.

9.2 Maintenance

- Use and store the product in a proper and normal environment.
- Periodically clean the surface and panel of servo drive and motor.
- Make sure the conductors or insulators are corroded and/or damaged.
- Do not disassemble or damage any mechanical part when performing maintenance.
- Clean off any dust and dirt with a vacuum cleaner. Place special emphasis on cleaning the ventilation ports and PCBs. Always keep these areas clean, as accumulation of dust and dirt can cause unforeseen failures.

9.3 Life of Replacement Components

■ Smooth capacitor

The characteristics of smooth capacitor would be deteriorated by ripple current affection. The life of smooth capacitor varies according to ambient temperature and operating conditions. The common guaranteed life of smooth capacitor is ten years when it is properly used in normal air-conditioned environment.

■ Relay

The contacts will wear and result in malfunction due to switching current. The life of relay varies according to power supply capacity. Therefore, the common guaranteed life of relay is cumulative 100,000 times of power on and power off.

Chapter 9 Maintenance and Inspection | ASDA-A&A+ Series

■ **Cooling fan**

The cooling fan life is limited and should be changed periodically. The cooling fan will reach the end of its life in 2~3 years when it is in continuous operation. However, it also must be replaced if the cooling fan is vibrating or there are unusual noises.

Chapter 9 Maintenance and Inspection | ASDA-A&A+ Series

This page intentionally left blank.

Chapter 10 Troubleshooting

If a fault is detected on the servo drive or motor a corresponding fault code will be shown on the drive's LED display. Fault codes can also be transmitted via communication, see P0-01 and P4-00 ~ P4-04 for display on controller or HMI.

10.1 Fault Messages Table

Servo Drive Fault Messages

Fault Messages		
Display	Fault Name	Fault Description
ALE01	Overcurrent	Main circuit current is higher than 1.5 multiple of motor's instantaneous maximum current value.
ALE02	Overvoltage	Main circuit voltage has exceeded its maximum allowable value.
ALE03	Undervoltage	Main circuit voltage is below its minimum specified value.
ALE04	Reserved	
ALE05	Regeneration error	Regeneration control operation is in error.
ALE06	Overload	Servo motor and drive is overload.
ALE07	Overspeed	Motor's control speed exceeds the limit of normal speed.
ALE08	Abnormal pulse control command	Input frequency of pulse command exceeds the limit of its allowable setting value.
ALE09	Excessive deviation	Position control deviation value exceeds the limit of its allowable setting value.
ALE10	Watch dog execution time out	Watch dog execution time out.
ALE11	Encoder error	Pulse signal is in error.
ALE12	Adjustment error	Adjusted value exceeds the limit of its allowable setting value when perform electrical adjustment.
ALE13	Emergency stop activated	Emergency stop switch is activated.
ALE14	Reverse limit switch error	Reverse limit switch is activated.
ALE15	Forward limit switch error	Forward limit switch is activated.

Chapter 10 Troubleshooting | ASDA-A&A+ Series

Fault Messages		
Display	Fault Name	Fault Description
ALE16	IGBT temperature error	The temperature of IGBT is over high.
ALE17	Memory error	EE-PROM write-in and read-out is in error.
ALE18	DSP communication error	The communication between DSP and MCU is in error. DSP do not respond to MCU command. The problem is on DSP side.
ALE19	Serial communication error	RS232/485 communication is in error.
ALE20	Serial communication time out	RS232/485 communication time out.
ALE21	Command write-in error	Control command write-in error.
ALE22	Input power phase loss	One phase of the input power is loss.
ALE23	Pre-overload warning	To warn that the servo motor and drive is going to overload. This alarm will display before ALM06. When the servo motor reach the setting value of P1-56, the motor will send a warning to the drive. After the drive has detected the warning, the DO signal OLW will be activated and this fault message will display.
ALE97	Internal command execution time out	An error occurs when internal command is executing.
ALE98	DSP communication error	<ol style="list-style-type: none"> 1. DSP do not respond to MCU command. 2. DSP has responded to MCU command but there is error in response message. Maybe the hardware is damaged.
ALE99	DSP communication error	<ol style="list-style-type: none"> 1. DSP do not respond to MCU command. 2. DSP has responded to MCU command but there is error in response message. Maybe the hardware is damaged.

Servo Drive Fault Messages (ASDA-A+ Series Only)

Fault Messages		
Display	Fault Name	Fault Description
ALE04	"Mismatch" error	The servo drive and servo motor are not correctly match for size (power rating)
ALE24	Encoder error	Z pulse shift. The corresponding angle of magnetic field of Z phase is error.
ALE25	Encoder error	The servo drive automatically detect the servo motor is in error.

 **NOTE**

- 1) If there is any unknown fault code that is not listed on the above table, please inform the distributor or contact with Delta for assistance.

Chapter 10 Troubleshooting | ASDA-A&A+ Series

10.2 Potential Cause and Corrective Actions

Servo Drive Fault Messages

ALED01 : Overcurrent

Potential Cause	Checking Method	Corrective Actions
Short-circuit at drive output (U, V, W)	<ol style="list-style-type: none"> 1. Check the wiring connections between drive and motor. 2. Check if the wire is short-circuited. 	Repair the short-circuited and avoid metal conductor being exposed.
Motor wiring error	Check if the wiring steps are all correct when connecting motor to drive.	Follow the wiring steps in the user manual to reconnect wiring.
IGBT error	Heat sink overheated	Please contact your distributor for assistance or contact with Delta.
Control parameter setting error	Check if the setting value exceeds the factory default setting.	Set the setting back to factory default setting and then reset and adjust the parameter setting again.
Control command setting error	Check if the control input command is unstable (too much fluctuation).	<ol style="list-style-type: none"> 1. Ensure that input command frequency is stable (too much fluctuation). 2. Activate filter function.

ALED02 : Overvoltage

Potential Cause	Checking Method	Corrective Actions
The main circuit voltage has exceeded its maximum allowable value.	Use voltmeter to check whether the input voltage falls within the rated input voltage. (For voltage specification, please refer to section 11.1 in Chapter11.)	Use correct power supply or stabilizing power.
Input power error (Incorrect power input)	Use voltmeter to check whether the input voltage is within the specified limit.	Use correct power supply or stabilizing power.

ALED03 : Undervoltage

Potential Cause	Checking Method	Corrective Actions
The main circuit voltage is below its minimum specified value.	Check whether the wiring of main circuit input voltage is normal.	Reconfirm voltage wiring.
No input voltage at main circuit.	Use voltmeter to check whether input voltage at main circuit is normal.	Reconfirm power switch.
Input power error (Incorrect power input)	Use voltmeter to check whether the input voltage is within the specified limit.	Use correct power supply or serial stabilizing power.

ALED04 : Reserved

Chapter 10 Troubleshooting | ASDA-A&A+ Series**ALE05 : Regeneration error**

Potential Cause	Checking Method	Corrective Actions
Regenerative resistor is not connected.	Check the wiring connection of regenerative resistor.	Reconnect regenerative resistor.
Regenerative switch transistor fault	Check if regenerative switch transistor is short-circuited.	Please contact your distributor for assistance or contact with Delta.
Parameter setting is in error	Confirm the parameter setting and specifications of regenerative resistor.	Correctly reset parameter again.

ALE06 : Overload

Potential Cause	Checking Method	Corrective Actions
The drive has exceeded its rated load during continuous operation.	Check if the drive is overloaded.	Increase motor capacity or reduce load.
Control system parameter setting is incorrect.	Check if there is mechanical vibration	Adjust gain value of control circuit.
	Accel/Decel time setting is too fast.	Decrease Accel/Decel time setting.
The wiring of drive and encoder is in error.	Check the wiring of U, V, W and encoder.	Ensure all wiring is correct.

ALE07 : Overspeed

Potential Cause	Checking Method	Corrective Actions
Speed input command is not stable (too much fluctuation).	Use signal detector to detect if input signal is abnormal.	Ensure that input command frequency is stable (not fluctuate too much) and activate filter function (P1-06, P1-07 and P1-08).
Over-speed parameter setting is defective.	Check if over-speed parameter setting value is too low.	Correctly set over-speed parameter setting (P2-34).

ALE08 : Abnormal pulse control command

Potential Cause	Checking Method	Corrective Actions
Pulse command frequency is higher than rated input frequency.	Use pulse frequency detector to measure input frequency.	Correctly set the input pulse frequency.

ALE09 : Excessive deviation

Potential Cause	Checking Method	Corrective Actions
Maximum deviation parameter setting is too small.	Check the maximum deviation parameter setting and observe the position error value when the motor is running.	Increases the parameter setting value of P2-35.
Gain value is too small.	Check for proper gain value.	Correctly adjust gain value.
Torque limit is too low.	Check torque limit value.	Correctly adjust torque limit value.
There is an overload.	Check for overload condition.	Reduce external applied load or re-estimate the motor capacity.

Chapter 10 Troubleshooting | ASDA-A&A+ Series

ALE 10 : Watch dog execution time out

Potential Cause	Checking Method	Corrective Actions
Watch dog execution error.	Check and reset the power supply.	If there are any abnormal conditions after resetting the power supply, please contact your distributor for assistance or contact with Delta.

ALE 11 : Encoder error (Position detector fault)

Potential Cause	Checking Method	Corrective Actions
The wiring of encoder is in error.	<ol style="list-style-type: none"> 1. Check if all wiring is correct. 2. Check if the users conduct the wiring by the wiring information in the user manual. 	Ensure all wiring is correct.
Encoder is loose	Examine the encoder connector.	Install the motor again.
The wiring of encoder is defective.	Check if all connections are tight.	Conduct the wiring again.
Encoder is damage	Check the motor for the damage.	Repair or replace the motor.
The circuit (loop) of Encoder is in error.	Check the drive for the damage.	Repair or replace the drive.

ALE 12 : Adjustment error

Potential Cause	Checking Method	Corrective Actions
The setting value of drift adjustment has exceeded its maximum allowable value.	<ol style="list-style-type: none"> 1. Remove CN1 wiring. 2. Execute the drift adjustment again. (Set P2-08 to 20 first, and then set P4-10 to 5.) 	If the error does not clear after executing the drift adjustment again, please contact your distributor for assistance or contact with Delta.

ALE 13 : Emergency stop activated

Potential Cause	Checking Method	Corrective Actions
Emergency stop switch is activated.	Check if emergency stop switch is On or Off.	Activate emergency stop switch.

ALE 14 : Reverse (CWL) limit switch error

Potential Cause	Checking Method	Corrective Actions
Reverse limit switch is activated.	Check if reverse limit switch is On or Off.	Activate reverse limit switch.
Servo system is not stable.	Check the value of control parameter setting and load inertia.	Modify parameter setting and re-estimate motor capacity.

Chapter 10 Troubleshooting | ASDA-A&A+ Series**ALE 15 : Forward (CCWL) limit switch error**

Potential Cause	Checking Method	Corrective Actions
Forward limit switch is activated.	Check if forward limit switch is On or Off.	Activate forward limit switch.
Servo system is not stable.	Check the value of control parameter setting and load inertia.	Modify parameter setting and re-estimate motor capacity.

ALE 16 : IGBT temperature error

Potential Cause	Checking Method	Corrective Actions
The drive has exceeded its rated load during continuous operation.	Check if there is overload or the motor current is too high.	Increase motor capacity or reduce load.
Short-circuit at drive output.	Check the drive input wiring.	Ensure all wiring is correct.

ALE 17 : Memory error

Potential Cause	Checking Method	Corrective Actions
Data error in Memory read-out / write-in.	Reset parameter or power supply.	If the error does not clear after resetting the power supply, please contact your distributor for assistance or contact with Delta.

ALE 18 : DSP communication error

Potential Cause	Checking Method	Corrective Actions
Control power is in error.	Check and reset control power	If the error does not clear after resetting the power supply, please contact your distributor for assistance or contact with Delta.

ALE 19 : Serial communication error

Potential Cause	Checking Method	Corrective Actions
Communication parameter setting is defective.	Check the communication parameter setting.	Correctly set parameter setting.
Communication address is incorrect.	Check the communication address.	Correctly set communication address.
Communication value is incorrect.	Check the communication value.	Correctly set communication value.

Chapter 10 Troubleshooting | ASDA-A&A+ Series

ALE20 : Serial communication time out

Potential Cause	Checking Method	Corrective Actions
Setting value in time out parameter is not correct.	Check communication time out parameter setting.	Correctly set P3-07.
Not receiving communication command for a long time.	Check whether communication cable is loose or broken.	Tighten the communication cable, make sure the communication cable is not damaged and ensure all wiring is correct.

ALE21 : Command write-in error

Potential Cause	Checking Method	Corrective Actions
Control power is in error.	Check and reset control power	If the error does not clear after resetting the power supply, please contact your distributor for assistance or contact with Delta.

ALE22 : Input power phase loss

Potential Cause	Checking Method	Corrective Actions
Control power supply is in error.	Check the power cable and connections of R, S, T. Check whether the power cable is loose or the possible loss of phase on input power.	If the fault does not clear even when the three-phase power is connected correctly, please contact your distributor for assistance or contact with Delta.

ALE23 : Pre-overload warning

Potential Cause	Checking Method	Corrective Actions
The drive is going to overload.	<ol style="list-style-type: none"> 1. Check the load condition of the servo motor and drive. 2. Check the setting value of P1-56. Check whether the setting value of P1-56 is too small. 	<ol style="list-style-type: none"> 1. Please refer to the correction actions of ALE06. 2. Increase the setting value of P1-56 or set P1-56 to 100 and above.

ALE97 : Internal command execution time out

Potential Cause	Checking Method	Corrective Actions
An error occurs when internal command is executing.	Check and reset control power	If the error does not clear after resetting the power supply, please contact your distributor for assistance or contact with Delta.

ALE98 : DSP communication error

Potential Cause	Checking Method	Corrective Actions
Maybe the hardware is damaged.	Check and reset control power	If the error does not clear after resetting the power supply, please contact your distributor for assistance or contact with Delta.

Chapter 10 Troubleshooting | ASDA-A&A+ Series**ALE99** : DSP communication error

Potential Cause	Checking Method	Corrective Actions
Maybe the hardware is damaged.	Check and reset control power	If the error does not clear after resetting the power supply, please contact your distributor for assistance or contact with Delta.

Servo Drive Fault Messages (ASDA-A+ Series Only)**ALE04** : "Mismatch" error

Potential Cause	Checking Method	Corrective Actions
The type of the servo motor is incorrect.	Check if the servo drive and servo motor are not correctly matched for size (power rating).	Repair or replace the servo drive or the servo motor.

ALE24 : Encoder error (Position detector fault)

Potential Cause	Checking Method	Corrective Actions
Maybe the Encoder is damaged.	If the error does not clear after resetting the power supply, please contact your distributor for assistance or contact with Delta.	

ALE25 : Encoder error (Position detector fault)

Potential Cause	Checking Method	Corrective Actions
The servo drive automatically detect the servo motor is in error.	<ol style="list-style-type: none"> 1. Check if the servo motor is properly grounded. 2. Check if the encoder signal cables are placed in separate conduits from the cables connected to R, S, T and U, V, W terminals to prevent the interference. 3. Check if the shielded cables are used when performing Encoder wiring. 	<ol style="list-style-type: none"> 1. Please connect the grounding (green color) of U, V, W terminal to the heatsink of the servo drive. 2. Ensure that the encoder signal cables are placed in separate conduits from the cables connected to R, S, T and U, V, W terminals to prevent the interference. 3. Please use shielded cables for Encoder wiring.

Chapter 10 Troubleshooting | ASDA-A&A+ Series**10.3 Clearing Faults**

Display	Fault Name	Clearing Method
ALE01	Overcurrent	Turn ARST (DI signal) ON to clear the fault or restart the servo drive.
ALE02	Overvoltage	Turn ARST (DI signal) ON to clear the fault or restart the servo drive.
ALE03	Undervoltage	This fault message can be removed automatically after the voltage has returned within its specification.
ALE04	Reserved	
ALE05	Regeneration error	Turn ARST (DI signal) ON to clear the fault or restart the servo drive.
ALE06	Overload	Turn ARST (DI signal) ON to clear the fault or restart the servo drive.
ALE07	Overspeed	Turn ARST (DI signal) ON to clear the fault or restart the servo drive.
ALE08	Abnormal pulse control command	Turn ARST (DI signal) ON to clear the fault or restart the servo drive.
ALE09	Excessive deviation	Turn ARST (DI signal) ON to clear the fault or restart the servo drive.
ALE10	Watch dog execution time out	This fault message cannot be cleared.
ALE11	Encoder error	This fault message can be removed by restarting the servo drive.
ALE12	Adjustment error	This fault message can be removed after the wiring of CN1 connector (I/O signal connector) is removed and auto adjustment function is executed.
ALE13	Emergency stop activated	This fault message can be removed automatically by turning off EMGS (DI signal).
ALE14	Reverse limit switch error	Turn ARST (DI signal) ON to clear the fault. This fault message can be removed when the servo drive is Off (Servo Off)
ALE15	Forward limit switch error	Turn ARST (DI signal) ON to clear the fault. This fault message can be removed when the servo drive is Off (Servo Off)
ALE16	IGBT temperature error	Turn ARST (DI signal) ON to clear the fault or restart the servo drive.
ALE17	Memory error	Turn ARST (DI signal) ON to clear the fault or restart the servo drive.
ALE18	DSP communication error	Turn ARST (DI signal) ON to clear the fault or restart the servo drive.
ALE19	Serial communication error	Turn ARST (DI signal) ON to clear the fault. This fault message can also be removed automatically after the communication is normal.
ALE20	Serial communication time out	Turn ARST (DI signal) ON to clear the fault or restart the servo drive.

Chapter 10 Troubleshooting | ASDA-A&A+ Series

Display	Fault Name	Clearing Method
ALE21	Command write-in error	Turn ARST (DI signal) ON to clear the fault or restart the servo drive.
ALE22	Input power phase loss	Turn ARST (DI signal) ON to clear the fault. This fault message can be removed automatically after input power phase lost problem is solved.
ALE23	Pre-overload warning	Turn ARST (DI signal) ON to clear the fault or restart the servo drive.
ALE97	Internal command execution time out	Turn ARST (DI signal) ON to clear the fault or restart the servo drive.
ALE98	DSP communication error	Turn ARST (DI signal) ON to clear the fault or restart the servo drive.
ALE99	DSP communication error	Turn ARST (DI signal) ON to clear the fault or restart the servo drive.

ASDA-A+ Series Only





ALE01	Overcurrent	This fault message can be removed by restarting the servo drive.
ALE04	"Mismatch" error	This fault message can be removed by restarting the servo drive.
ALE24	Encoder error (Position detector fault)	This fault message can be removed by rotating the motor shaft first and then restarting the servo drive.
ALE25	Encoder error (Position detector fault)	This fault message can be removed by restarting the servo drive.

Chapter 11 Specifications

11.1 Specifications of Servo Drive (ASDA-A Series)

ASDA-A Series		100W	200W	400W	750W	1kW	1.5kW	2kW	3kW	
		01	02	04	07	10	15	20	30	
Power supply	Phase / Voltage	Three-phase or Single-phase 220VAC						Three-phase 220VAC		
	Permissible Voltage Range	Three-phase: 170 ~ 255VAC						170 ~ 255VAC		
		Single-phase: 200 ~ 255VAC								
Permissible Frequency Range	50/60Hz ±5%									
Cooling System	Natural Air Circulation				Fan Cooling					
Encoder Resolution / Feedback Resolution	2500ppr/10000ppr									
Control of Main Circuit	SVPWM Control									
Tuning Modes	Easy / Auto / Manual									
Dynamic Brake	Built-in									
Position Control Mode	Max. Input Pulse Frequency	Max. 500Kpps (Line driver), Max. 200Kpps (Open collector)								
	Pulse Type	Pulse + Direction, A phase + B phase, CCW pulse + CW pulse								
	Command Source	External pulse train / Internal parameters								
	Smoothing Strategy	Low-pass and P-curve filter								
	Electronic Gear	Electronic gear N/M multiple N: 1~32767, M: 1:32767 (1/50<N/M<200)								
	Torque Limit Operation	Set by parameters								
	Feed Forward Compensation	Set by parameters								
Analog Input Command	Voltage Range	0 ~ ±10 V _{DC}								
	Input Resistance	10KΩ								
	Time Constant	2.2 us								
Speed Control Range ^{*1}	1:5000									
Command Source	External analog signal / Internal parameters									
Smoothing Strategy	Low-pass and S-curve filter									
Torque Limit Operation	Set by parameters or via Analog input									
Frequency Response Characteristic	Maximum 450Hz									
Speed Fluctuation Rate ^{*2}	0.01% or less at load fluctuation 0 to 100% (at rated speed)									
	0.01% or less at power fluctuation ±10% (at rated speed)									
	0.01% or less at ambient temperature fluctuation 0°C to 50°C (at rated speed)									

Chapter 11 Specifications | ASDA-A&A+ Series

ASDA-A Series		100W	200W	400W	750W	1kW	1.5kW	2kW	3kW
		01	02	04	07	10	15	20	30
Torque Control Mode	Analog Input Command	Voltage Range	0 ~ ±10 V _{DC}						
		Input Resistance	10KΩ						
		Time Constant	2.2 us						
	Command Source	External analog signal / Internal parameters							
	Smoothing Strategy	Low-pass filter							
	Speed Limit Operation	Parameter Setting or via Analog input							
Analog Monitor Output		Monitor signal can set by parameters (Output voltage range: ±8V)							
Digital Input/Output	Input	Servo On, Reset, Gain switching, Pulse clear, Zero speed CLAMP, Speed/Torque limit enabled, Emergency stop, Forward / Reverse inhibit limit, Position / Speed mode switching, Speed / Torque mode switching, Torque / Position mode switching, Feed step selection input, Feed step mode input, Auto run input, Electronic gear ratio (Numerator) selection							
	Output	Encoder signal output (A, B, Z Line Driver / Z Open collector) Servo ready, Servo On, At Zero speed, At Speed reached, At Positioning completed, At Torques limit, Servo alarm (Servo fault) activated, Electromagnetic brake control, Homing completed, Output overload warning, Servo warning activated, Internal position command completed							
Protective Functions		Overcurrent, Overvoltage, Undervoltage, Motor overheated, Regeneration error, Overload, Overspeed, Abnormal pulse control command, Excessive deviation, Watch dog execution time out, Encoder error, Adjustment error, Emergency stop activated, Reverse/ Forward limit switch error, Memory error, DSP communication error, Serial communication error, Input power phase loss, Serial communication time out, Command write-in error, short circuit protection of U, V, W, and CN1, CN2, CN3 terminals							
Environment	Communication Interface	RS-232 / RS-485 / RS-422							
	Installation Site	Indoor location (free from direct sunlight), no corrosive liquid and gas (far away from oil mist, flammable gas, dust)							
	Altitude	Altitude 1000m or lower above sea level							
	Atmospheric pressure	86kPa to 106kPa							
	Operating Temperature	0°C ~ 55°C (If operating temperature is above specified range, forced cooling will be required)							
	Storage Temperature	-20°C to 65°C (-4°F to 149°F)							
	Humidity	0 to 90% (non-condensing)							
Environment	Vibration	9.80665m/s ² (1G) less than 20Hz, 5.88m/s ² (0.6G) 20 to 50Hz							
	IP Rating	IP20							
	Power System	TN System ^{*3}							
	Approvals	IEC/EN 61800-5-1, UL 508C, TUV, C-tick     							

Chapter 11 Specifications | ASDA-A&A+ Series

Footnote:



- *1 Rated rotation speed: When full load, speed ratio is defined as the minimum speed (the motor will not pause).
- *2 When command is rated rotation speed, the speed fluctuation rate is defined as:
(Empty load rotation speed – Full load rotation speed) / Rated rotation speed
- *3 TN system: A power distribution system having one point directly earthed, the exposed conductive parts of the installation being connected to that points by protective earth conductor.
- *4 Please refer to “Chart of load and operating time” in section 11.7 “Overload Characteristics”.

Chapter 11 Specifications | ASDA-A&A+ Series

11.2 Specifications of Servo Drive (ASDA-A+ Series)

ASDA-A+ Series		4.5kW	5.5kW	7.5kW
		45	55	75
Power Supply	Phase / Voltage	Three-phase 220VAC		
	Permissible Voltage Range	170 ~ 255VAC		
	Permissible Frequency Range	50/60Hz ±5%		
Cooling System		Fan Cooling		
Feedback Resolution		1280000 p/rev		
Control of Main Circuit		SVPWM Control		
Tuning Modes		Auto / Manual		
Dynamic Brake		Built-in		
Position Control Mode	Max. Input Pulse Frequency	High-speed position pulse input: 4Mpps Max. 500Kpps (Line driver) / Max. 200Kpps (Open collector)		
	Pulse Type	Pulse + Direction, A phase + B phase, CCW pulse + CW pulse		
	Command Source	External pulse train / Internal parameters		
	Smoothing Strategy	Low-pass and P-curve filter		
	Electronic Gear	Electronic gear N/M multiple N: 1~32767, M: 1:32767 (1/50<N/M<200)		
	Torque Limit Operation	Set by parameters		
	Feed Forward Compensation	Set by parameters		
Speed Control Mode	Analog Input Command	Voltage Range	0 ~ ±10 V _{DC}	
		Input Resistance	10KΩ	
		Time Constant	2.2 us	
	Speed Control Range ^{*1}	1:3000		
	Command Source	External analog signal / Internal parameters		
	Smoothing Strategy	Low-pass and S-curve filter		
	Torque Limit Operation	Set by parameters or via Analog input		
	Frequency Response Characteristic	Maximum 550Hz		
	Speed Fluctuation Rate ^{*2}	0.01% or less at load fluctuation 0 to 100% (at rated speed)		
		0.01% or less at power fluctuation ±10% (at rated speed)		
0.01% or less at ambient temperature fluctuation 0°C to 50°C (at rated speed)				
Torque Control Mode	Analog Input Command	Voltage Range	0 ~ ±10 V _{DC}	
		Input Resistance	10KΩ	
		Time Constant	2.2 us	
	Command Source	External analog signal / Internal parameters		
	Smoothing Strategy	Low-pass filter		
Speed Limit Operation	Parameter Setting or via Analog input			

Chapter 11 Specifications | ASDA-A&A+ Series

ASDA-A+ Series		4.5kW	5.5kW	7.5kW
		45	55	75
Analog Monitor Output		Monitor signal can set by parameters (Output voltage range: $\pm 8V$)		
Digital Input/Output	Input	Servo On, Reset, Gain switching, Pulse clear, Zero speed CLAMP, Speed/Torque limit enabled, Emergency stop, Forward / Reverse inhibit limit, Position / Speed mode switching, Speed / Torque mode switching, Torque / Position mode switching, Feed step selection input, Feed step mode input, Auto run input, Electronic gear ratio (Numerator) selection		
	Output	Encoder signal output (A, B, Z Line Driver / Z Open collector) Servo ready, Servo On, At Zero speed, At Speed reached, At Positioning completed, At Torques limit, Servo alarm (Servo fault) activated, Electromagnetic brake control, Homing completed, Output overload warning, Servo warning activated, Internal position command completed		
Protective Functions		Overcurrent, Overvoltage, Undervoltage, Motor overheated, Regeneration error, Overload, Overspeed, Abnormal pulse control command, Excessive deviation, Watch dog execution time out, Encoder error, Adjustment error, Emergency stop activated, Reverse/ Forward limit switch error, Memory error, DSP communication error, Serial communication error, Input power phase loss, Serial communication time out, Command write-in error, short circuit protection of U, V, W, and CN1, CN2, CN3 terminals		
Communication Interface		RS-232 / RS-485 / RS-422		
Environment	Installation Site	Indoor location (free from direct sunlight), no corrosive liquid and gas (far away from oil mist, flammable gas, dust)		
	Altitude	Altitude 1000m or lower above sea level		
	Atmospheric pressure	86kPa ~ 106kPa		
	Operating Temperature	0°C to 55°C (If operating temperature is above specified range, forced cooling will be required)		
	Storage Temperature	-20°C to 65°C (-4°F to 149°F)		
	Humidity	0 to 90% (non-condensing)		
	Vibration	9.80665m/s ² (1G) less than 20Hz, 5.88m/s ² (0.6G) 20 to 50Hz		
	IP Rating	IP20		
	Power System	TN System ^{*3}		
	Approvals	IEC/EN 61800-5-1, UL 508C  		

Footnote:



- *1 Rated rotation speed: When full load, speed ratio is defined as the minimum speed (the motor will not pause).
- *2 When command is rated rotation speed, the speed fluctuation rate is defined as:
(Empty load rotation speed – Full load rotation speed) / Rated rotation speed
- *3 TN system: A power distribution system having one point directly earthed, the exposed conductive parts of the installation being connected to that points by protective earth conductor.
- *4 Please refer to “Chart of load and operating time” in section 11.7 “Overload Characteristics”.

Chapter 11 Specifications | ASDA-A&A+ Series

11.3 Low Inertia Servo Motor Specifications (ASMT□□L Series)

Model: ASMT□□L250□□	100W	200W	400W	750W	1kW	2kW	3kW
	01	02	04	07	10	20	30
Rated output power (kW)	0.1	0.2	0.4	0.75	1.0	2.0	3.0
Rated torque (N-m)	0.318	0.64	1.27	2.39	3.3	6.8	9.5
Maximum torque (N-m)	0.95	1.91	3.82	7.16	9.9	19.2	31.5
Rated speed (r/min)	3000						
Maximum speed (r/min)	5000				4500		
Rated current (A)	1.1	1.7	3.3	5.0	6.8	13.4	17.5
Maximum current (A)	3.0	4.9	9.3	14.1	18.7	38.4	55
Power rating (kW/s)	34.5	23.0	48.7	51.3	42	98	95.1
Rotor moment of inertia (Kg.m ²) (without brake)	0.03E-4	0.18E-4	0.34E-4	1.08E-4	2.6E-4	4.7E-4	11.6E-4
Mechanical time constant (ms)	0.6	0.9	0.7	0.6	1.7	1.2	1.5
Static friction torque (N-m)	0.02	0.04	0.04	0.08	0.49	0.49	0.49
Torque constant-KT (N-m/A)	0.32	0.39	0.4	0.5	0.56	0.54	0.581
Voltage constant-KE (mV/(r/min))	33.7	41.0	41.6	52.2	58.4	57.0	60.9
Armature resistance (Ohm)	20.3	7.5	3.1	1.3	2.052	0.765	0.32
Armature inductance (mH)	32	24	11	6.3	8.4	3.45	2.63
Electrical time constant (ms)	1.6	3.2	3.2	4.8	4.1	4.5	8.2
Insulation class	Class F						
Insulation resistance	>100MΩ, DC 500V						
Insulation strength	AC 1500 V, 50 Hz, 60 seconds						
Max. radial shaft load (N)	78.4	196	196	343	490	490	490
Max. thrust shaft load (N)	39.2	68.6	68.6	98	98	98	98
Vibration grade (μm)	15						
DC brake power (V)	24 ±10%						
Rotor moment of inertia (Kg.m ²) (with brake)	0.06E-4	0.28E-4	0.44E-4	1.32E-4	3.1E-4	5.2E-4	14.39E-4
Brake holding torque [Nt-m (min)]	0.32	1.27	1.27	2.55	9.3	9.3	13.5
Brake power consumption (at 20°C) [W]	5	9	9	9.5	17.9	17.9	30
Brake release time [ms (Max)]	20	20	20	50	20	20	20
Brake pull-in time [ms (Max)]	40	50	50	80	90	90	90
Operating temperature	0°C to 40°C (32°F to 104°F)						
Storage temperature (°C)	-20°C to 70°C (-4°F to 158°F)						
Operating humidity	20 to 90%RH (non-condensing)						
Storage humidity	20 to 90%RH (non-condensing)						
Vibration capacity	2.5G						

Chapter 11 Specifications | ASDA-A&A+ Series

Model: ASMT□□L250□□	100W	200W	400W	750W	1kW	2kW	3kW
	01	02	04	07	10	20	30
IP Rating	IP65 (when waterproof connectors are used, or when an oil seal is used to be fitted to the rotating shaft (an oil seal model is used))						
Approvals	IEC60034-1, UL1004  						

Chapter 11 Specifications | ASDA-A&A+ Series

11.4 Medium Inertia Servo Motor Specifications (ASMT□□M Series)

Model: ASMT□□M250□□	1kW	1.5kW	2kW	3kW
	10	15	20	30
Rated output power (kW)	1.0	1.5	2.0	3.0
Rated torque (N-m)	4.8	7.16	9.4	14.3
Maximum torque (N-m)	15.7	21.5	23.5	35.8
Rated speed (r/min)	2000			
Maximum speed (r/min)	3000			
Rated current (A)	5.6	10.6	13.1	17.4
Maximum current (A)	17.6	30.3	31.4	42.3
Power rating (kW/s)	38.4	58.3	55.6	47.2
Rotor moment of inertia (Kg.m ²) (without brake)	5.98E-4	8.79E-4	15.8E-4	43.3E-4
Mechanical time constant (ms)	1.4	1.3	1.6	0.9
Static friction torque (N-m)	0.29	0.5	0.98	0.98
Torque constant-KT (N-m/A)	0.91	0.73	0.77	0.86
Voltage constant-KE (mV/(r/min))	95.71	76.0	81.1	90.5
Armature resistance (Ohm)	1.98	0.828	0.6	0.162
Armature inductance (mH)	13.2	5.5	8.1	2.3
Electrical time constant (ms)	6.7	6.6	10.1	14.2
Insulation class	Class F			
Insulation resistance	>100MΩ, DC 500V			
Insulation strength	AC 1500 V, 50 Hz, 60 seconds			
Max. radial shaft load (N)	490	490	784	784
Max. thrust shaft load (N)	98	98	392	392
Vibration grade (μm)	15			
DC brake power (V)	24 ±10%			
Rotor moment of inertia (Kg.m ²) (with brake)	8.77 E-4	11.57 E-4	27.8 E-4	56.3 E-4
Brake holding torque [Nt-m (min)]	7.5	10.5	32	50
Brake power consumption (at 20°C) [W]	20	30	34.7	40
Brake release time [ms (Max)]	20	20	50	140
Brake pull-in time [ms (Max)]	90	90	170	110
Operating temperature	0°C to 40°C (32°F to 104°F)			
Storage temperature	-20°C to 70°C (-4°F to 158°F)			
Operating humidity	20~90%RH (non-condensing)			
Storage humidity	20~90%RH (non-condensing)			
Vibration capacity	2.5G			

Chapter 11 Specifications | ASDA-A&A+ Series

Model: ASMT□□M250□□	1kW	1.5kW	2kW	3kW
	10	15	20	30
IP Rating	IP65 (when waterproof connectors are used, or when an oil seal is used to be fitted to the rotating shaft (an oil seal model is used))			
Approvals	IEC60034-1, UL1004 			

Chapter 11 Specifications | ASDA-A&A+ Series**11.5 Medium and Medium / High Inertia Servo Motor Specifications (ECMA Series)**

Model: ECMA Series	E218	F218			
	35	30	45	55	75
Rated output power (kW)	3.5	3.0	4.5	5.5	7.5
Rated torque (N-m)	16.71	19.10	28.65	35.01	47.74
Maximum torque (N-m)	50.13	57.29	71.62	87.53	119.36
Rated speed (r/min)	2000	1500			
Maximum speed (r/min)	3000				
Rated current (A)	19.2	19.4	32.5	40.0	47.5
Maximum current (A)	57.6	58.2	81.3	100.0	118.8
Power rating (kW/s)	51	66.4	105.5	122.9	159.7
Rotor moment of inertia (Kg.m ²) (without brake)	54.95E-4	54.95E-4	77.75E-4	99.78E-4	142.7E-4
Mechanical time constant (ms)	1.06	1.28	0.92	0.96	0.63
Torque constant-KT (N-m/A)	0.87	0.98	0.88	0.88	1.01
Voltage constant-KE (mV/(r/min))	32	35.0	32.0	31.0	35.5
Armature resistance (Ohm)	0.052	0.077	0.032	0.025	0.015
Armature inductance (mH)	1.38	1.27	0.89	0.60	0.40
Electrical time constant (ms)	26.4	16.5	27.8	24.0	26.7
Insulation class	Class B (CE)				
Insulation resistance	>100MΩ, DC 500V				
Insulation strength	AC 1500 V, 50 Hz, 60 seconds				
Weight (kg) (without brake)	18.5	18.5	23.5	30.5	37.0
Max. radial shaft load (N)	1470	1470	1470	1764	1764
Max. thrust shaft load (N)	490	490	490	588	588
Vibration grade (μm)	15				
Operating temperature	0°C to 40°C (32°F to 104°F)				
Storage temperature	-10°C to 80°C (-14°F to 176°F)				
Operating humidity	20~90%RH (non-condensing)				
Storage humidity	20~90%RH (non-condensing)				
Vibration capacity	2.5G				
IP Rating	IP65 (when waterproof connectors are used, or when an oil seal is used to be fitted to the rotating shaft (an oil seal model is used))				
Approvals					

11.6 Servo Motor Speed-Torque Curves (T-N Curves)

■ Low Inertial Servo Motor Speed-Torque Curves

(ASMT□□L Series)

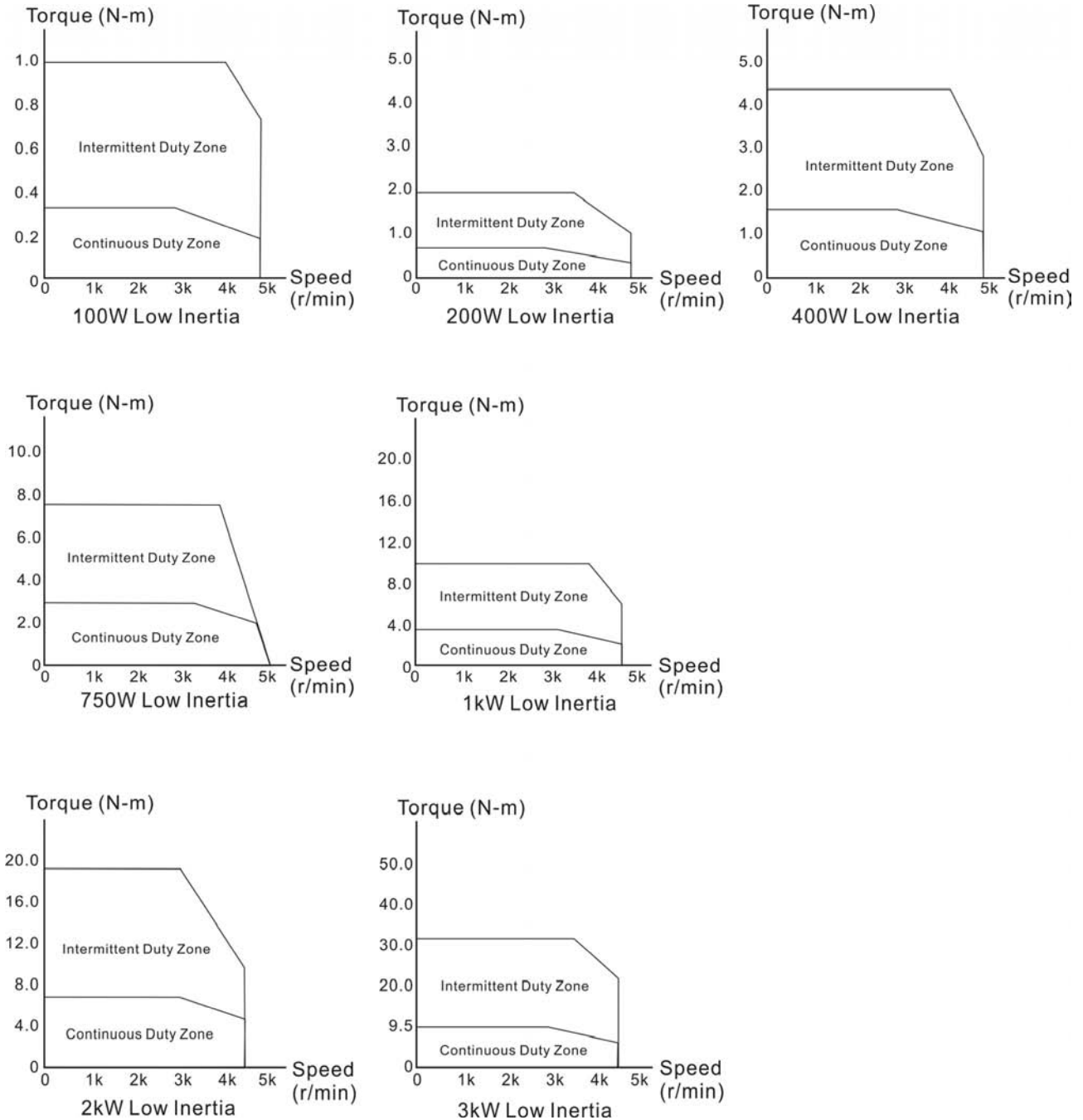

Chapter 11 Specifications | ASDA-A&A+ Series

■ Medium and Medium / High Inertial Servo Motor Speed-Torque Curves

(ASMT□□M Series)

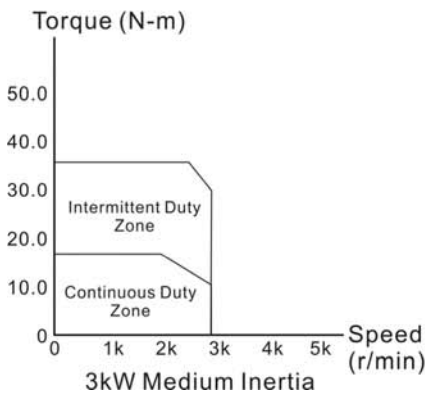
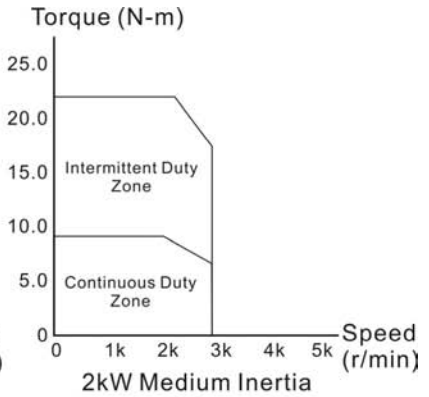
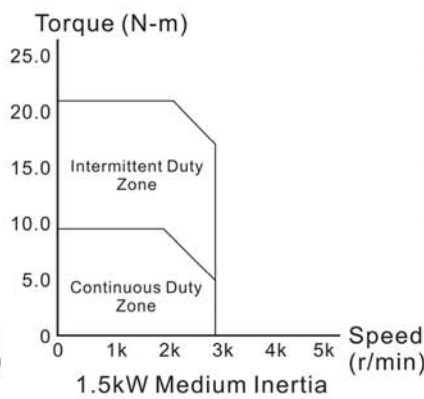
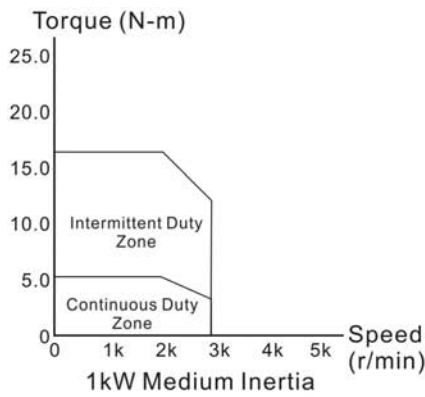

(ECMA Series)

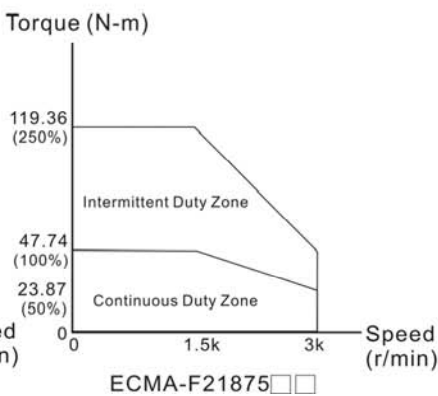
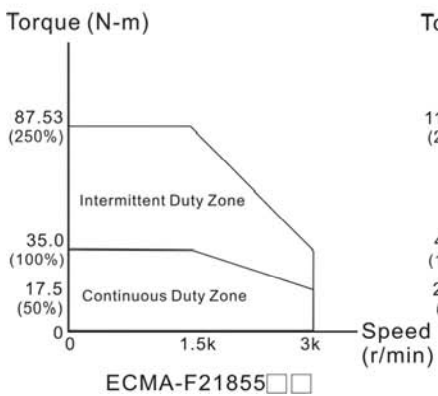
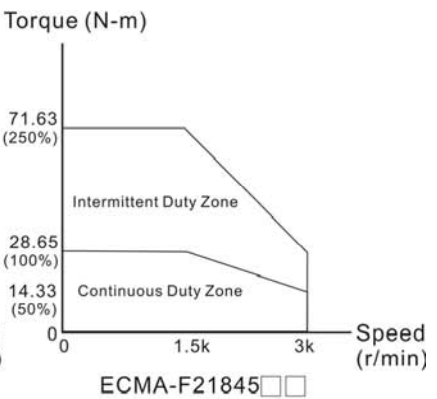
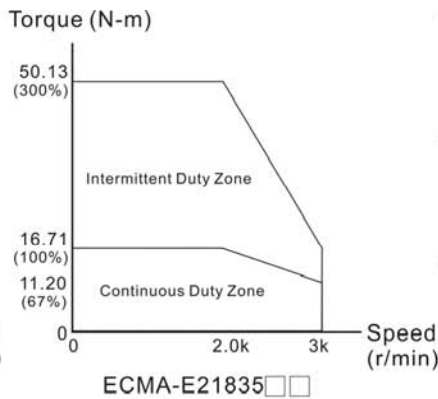
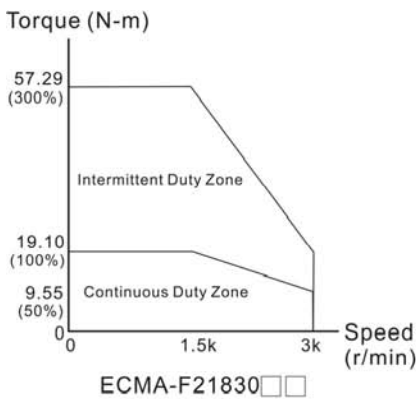

11.7 Overload Characteristics

■ Overload Protection Function

Overload protection is a built-in protective function to prevent a motor from overheating.

■ Occasion of Overload

1. Motor was operated for several seconds under a torque exceeding 100% torque.
2. Motor had driven high inertia machine and had accelerated and decelerated at high frequency.
3. Motor UVW cable or encoder cable was not connected correctly.
4. Servo gain was not set properly and caused motor hunting.
5. Motor holding brake was not released.

■ Chart of load and operating time (Low Inertia Servo Motor)

(ASMT□□L Series)

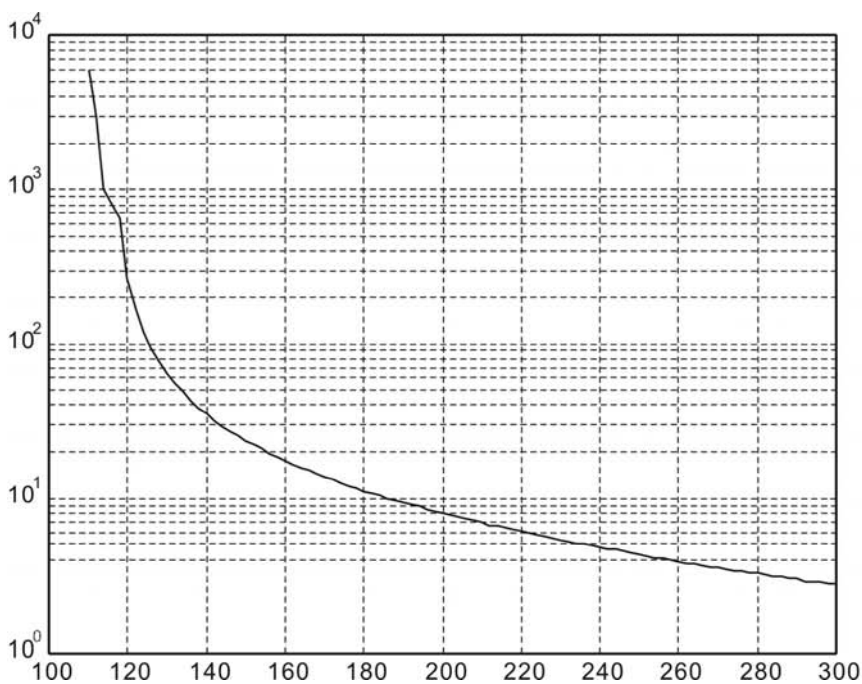

Load	Operating Time
120%	263.8s
140%	35.2s
160%	17.6s
180%	11.2s
200%	8s
220%	6.1s
240%	4.8s
260%	3.9s
280%	3.3s
300%	2.8s

Chapter 11 Specifications | ASDA-A&A+ Series

■ Chart of load and operating time (Medium and Medium / High Inertia Servo Motor)

(ASMT□□M Series)

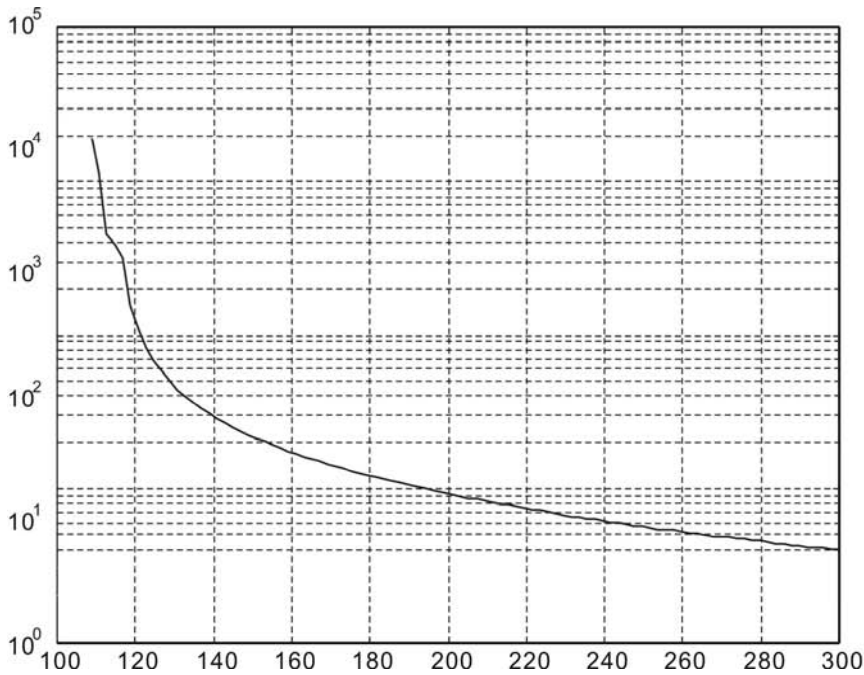

Load	Operating Time
120%	527.6s
140%	70.4s
160%	35.2s
180%	22.4s
200%	16s
220%	12.2s
240%	9.6s
260%	7.8s
280%	6.6s
300%	5.6s

(ECMA Series)

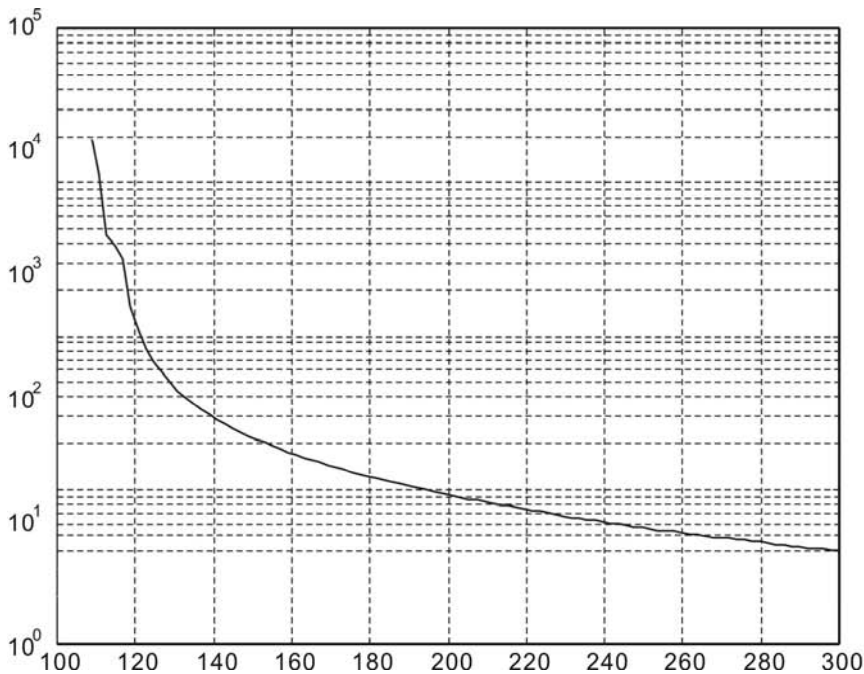

Load	Operating Time
120%	527.6s
140%	70.4s
160%	35.2s
180%	22.4s
200%	16s
220%	12.2s
240%	9.6s
260%	7.8s
280%	6.6s
300%	5.6s

Chapter 11 Specifications | ASDA-A&A+ Series

11.8 Dimensions of Servo Drive

Order P/N: ASD-A0121LA; ASD-A0221LA; ASD-A0421LA (100W ~ 400W)

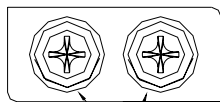
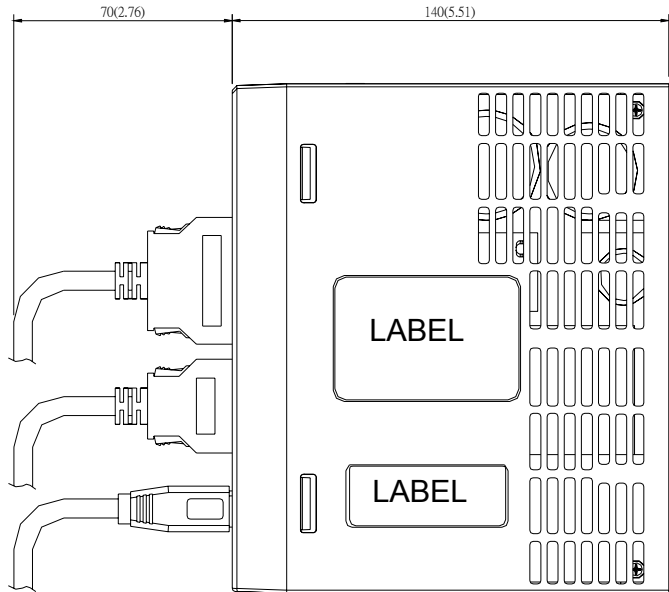
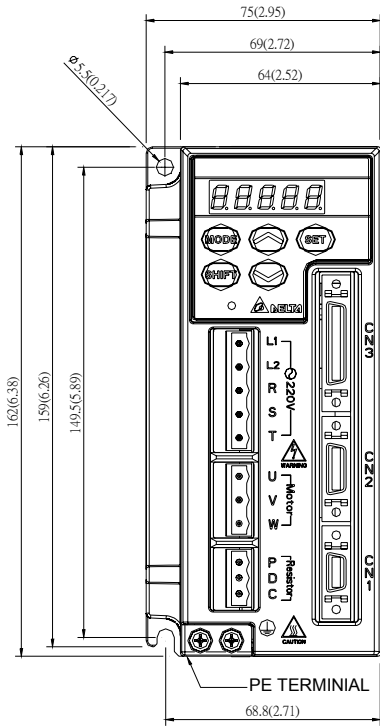

SCREW : M4x 0.7
MOUNTING SCREW TORQUE :14 (kgf-cm)

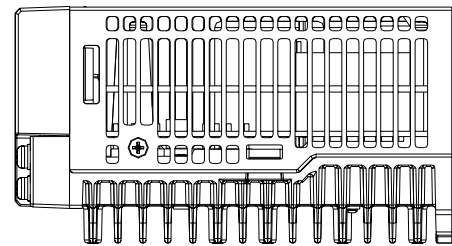

WEIGHT
1.5 (3.3)

NOTE

- 1) Dimensions are in millimeters (inches); Weights are in kilograms (kg) and (pounds (lbs)).
- 2) Actual measured values are in metric units. Dimensions and weights in (imperial units) are for reference only.
- 3) Dimensions and weights of the servo drive may be revised without prior notice.

Chapter 11 Specifications | ASDA-A&A+ Series

Order P/N: ASD-A0721LA; ASD-A1021□A; ASD-A1521□A (750W ~ 1.5kW)

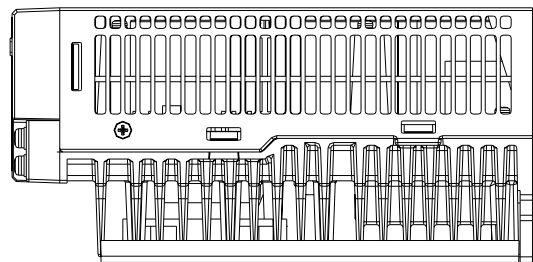
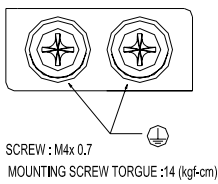
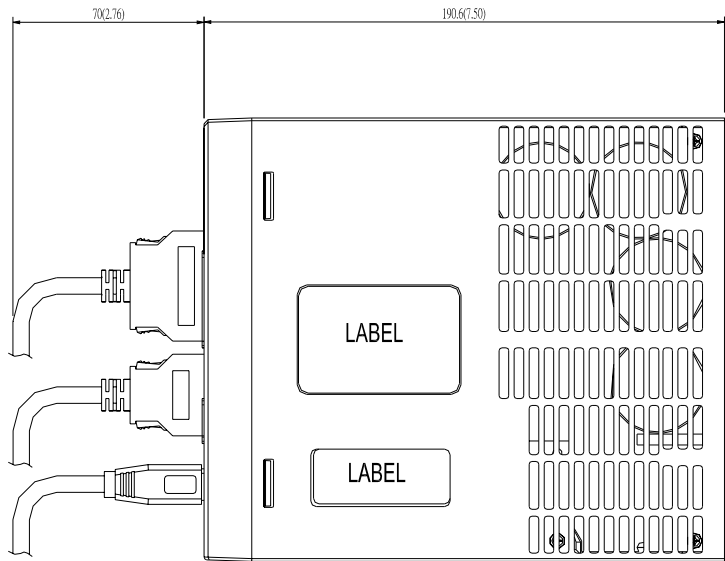
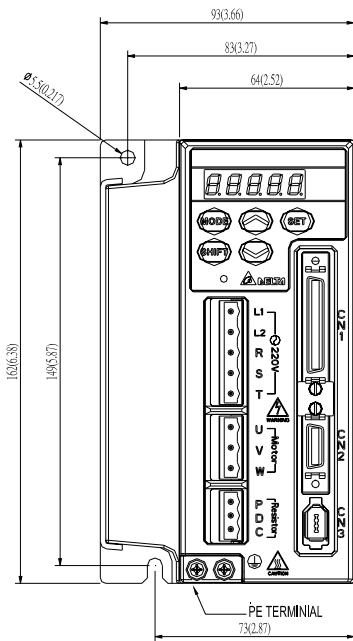

WEIGHT
2.0 (4.4)

NOTE

- 1) Dimensions are in millimeters (inches); Weights are in kilograms (kg) and (pounds (lbs)).
- 2) Actual measured values are in metric units. Dimensions and weights in (imperial units) are for reference only.
- 3) Dimensions and weights of the servo drive may be revised without prior notice.

Chapter 11 Specifications | ASDA-A&A+ Series

Order P/N: ASD-A2023□A; ASD-A3023□A (2kW ~ 3kW)

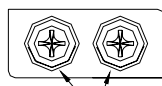
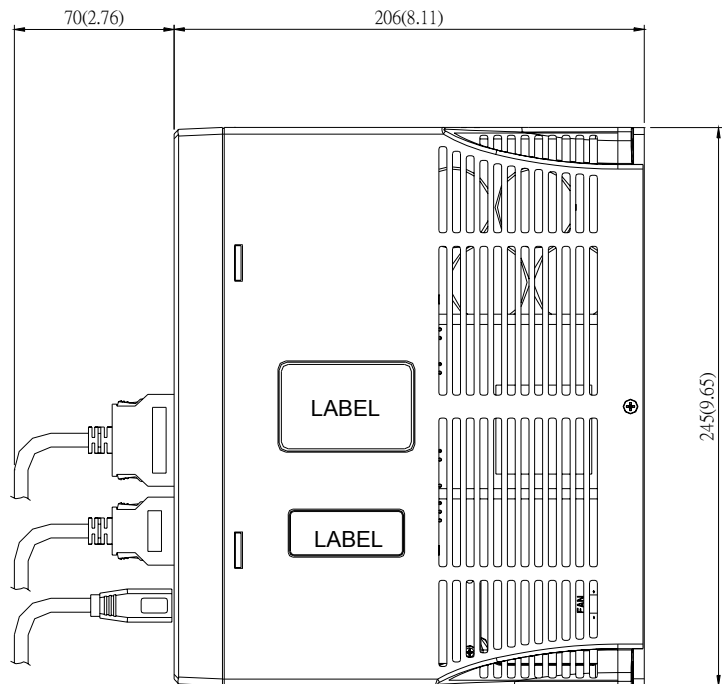
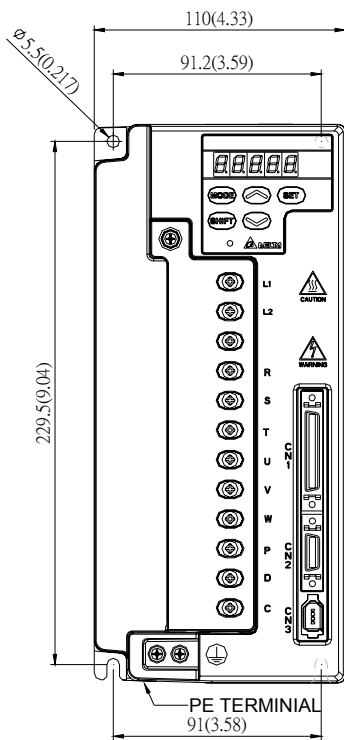

SCREW : M4x 0.7
MOUNTING SCREW TORQUE :14 (kgf-cm)

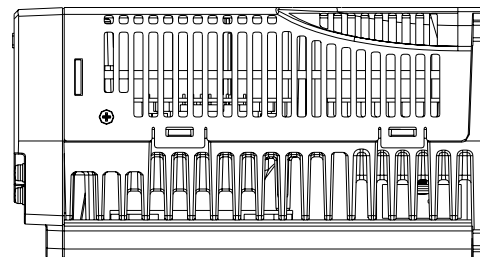

WEIGHT
3.0 (6.6)

NOTE

- 1) Dimensions are in millimeters (inches); Weights are in kilograms (kg) and (pounds (lbs)).
- 2) Actual measured values are in metric units. Dimensions and weights in (imperial units) are for reference only.
- 3) Dimensions and weights of the servo drive may be revised without prior notice.

Chapter 11 Specifications | ASDA-A&A+ Series

Order P/N: ASD-A4523-B (4.5kW)

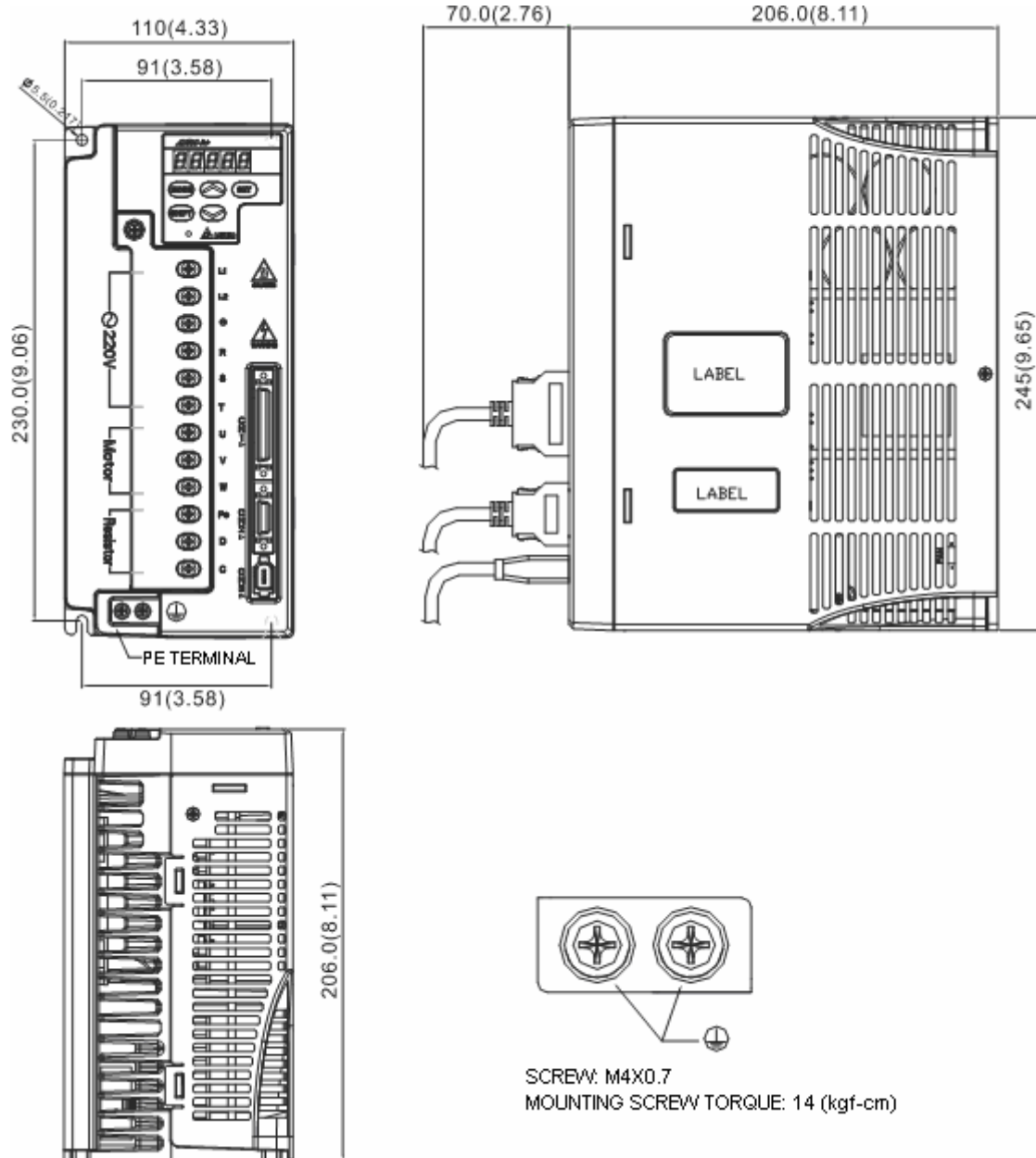

WEIGHT
3.0 (6.6)

NOTE

- 1) Dimensions are in millimeters (inches); Weights are in kilograms (kg) and (pounds (lbs)).
- 2) Actual measured values are in metric units. Dimensions and weights in (imperial units) are for reference only.
- 3) Dimensions and weights of the servo drive may be revised without prior notice.

Chapter 11 Specifications | ASDA-A&A+ Series

Order P/N: ASD-A5523-B (5.5kW)

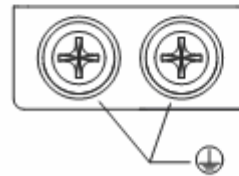
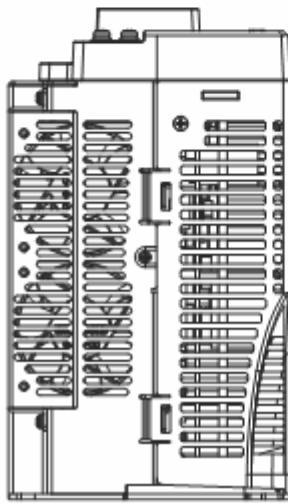
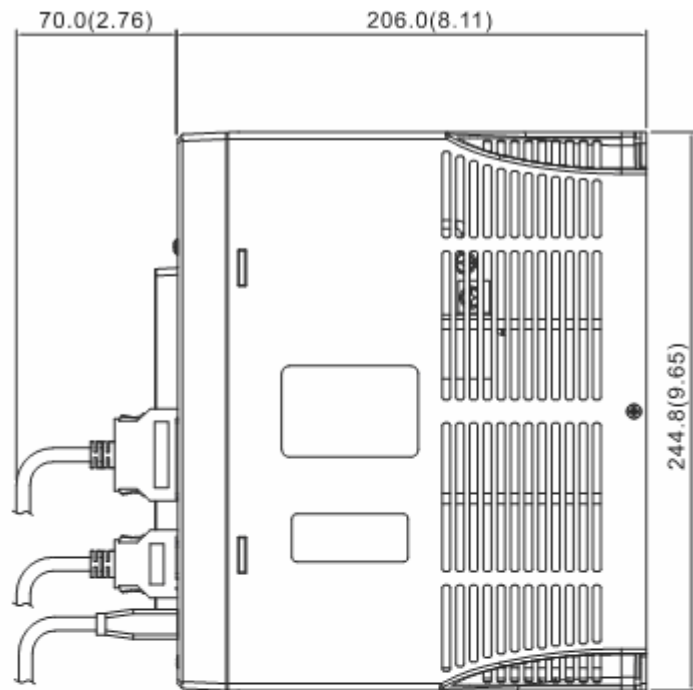
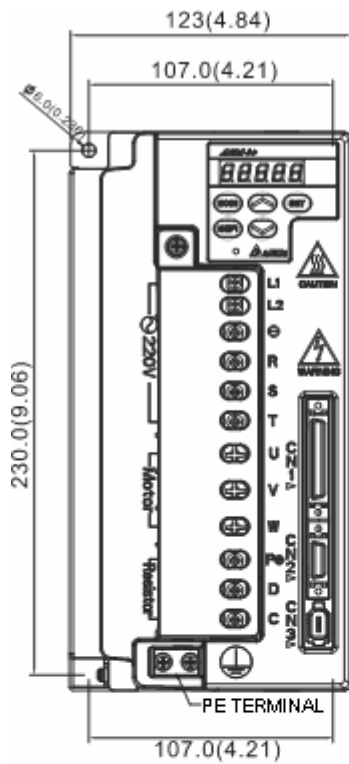

SCREW: M4 X 0.7
MOUNTING SCREW TORQUE: 14 (kgf-cm)

WEIGHT
5.5 (12.1)

 **NOTE**

- 1) Dimensions are in millimeters (inches); Weights are in kilograms (kg) and (pounds (lbs)).
- 2) Actual measured values are in metric units. Dimensions and weights in (imperial units) are for reference only.
- 3) Dimensions and weights of the servo drive may be revised without prior notice.

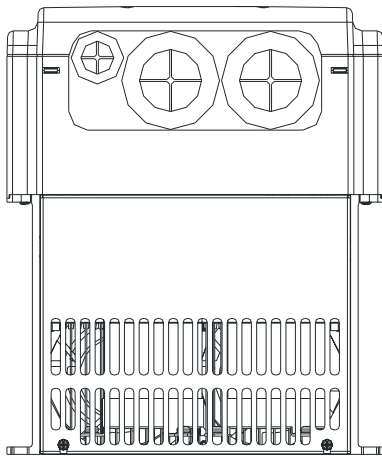
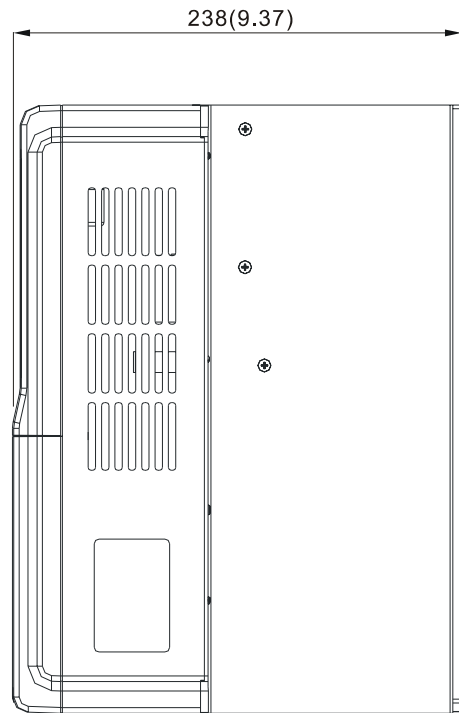
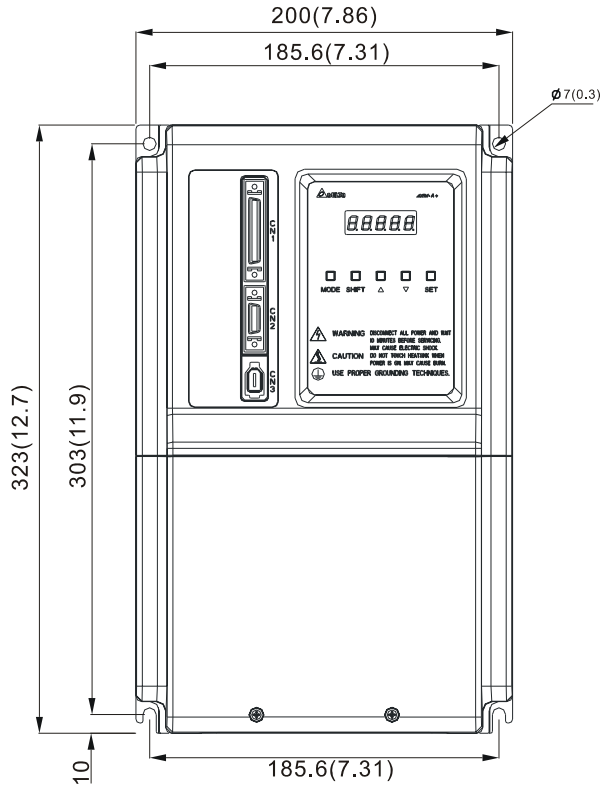
Chapter 11 Specifications | ASDA-A&A+ Series**Order P/N: ASD-A7523-B (7.5kW)**

WEIGHT
8.0 (17.6)

NOTE

- 1) Dimensions are in millimeters (inches); Weights are in kilograms (kg) and (pounds (lbs)).
- 2) Actual measured values are in metric units. Dimensions and weights in (imperial units) are for reference only.
- 3) Dimensions and weights of the servo drive may be revised without prior notice.

Chapter 11 Specifications | ASDA-A&A+ Series

11.9 Dimensions of Low Inertia Servo Motor (ASMT□□L Series)

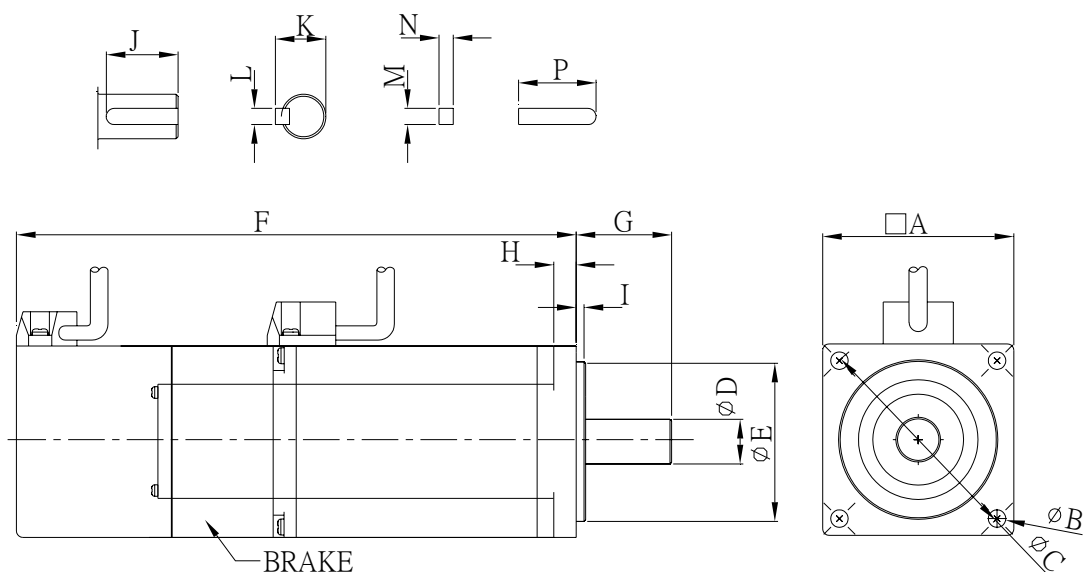

Model	ASMT01L250□□	ASMT02L250□□	ASMT04L250□□	ASMT07L250□□
A	40	60	60	80
B	4.5	5.5	5.5	6.6
C	46	70	70	90
D	8h6 +0.0 -0.009	14h6 +0.0 -0.011	14h6 +0.0 -0.011	19h6 +0.0 -0.013
E	30h7 +0.0 -0.021	50h7 +0.0 -0.025	50h7 +0.0 -0.025	70h7 +0.0 -0.030
F (without brake)	100.1	102.4	124.4	135
F (with brake)	135.7	137	159	171.6
G	25	30	30	35
H	5	6	6	8
I	2.5	3	3	3
J	16	20	20	25
K	9.2 +0.0 -0.2	16 +0.0 -0.2	16 +0.0 -0.2	21.5 +0.0 -0.2
L	3h9 -0.006 -0.031	5h9 -0.012 -0.042	5h9 -0.012 -0.042	6h9 -0.012 -0.042
M	3 +0.0 -0.025	5 +0.0 -0.030	5 +0.0 -0.030	6 +0.0 -0.030
N	3 +0.0 -0.025	5 +0.0 -0.030	5 +0.0 -0.030	6 +0.0 -0.030
P	16 +0.0 -0.18	20 +0.0 -0.21	20 +0.0 -0.21	25 +0.0 -0.21
Weight (without brake)	0.5 (1.1)	0.9 (1.98)	1.3 (2.87)	2.5 (5.5)
Weight (with brake)	0.7 (1.54)	1.4 (3.09)	1.8 (3.97)	3.4 (7.5)

 **NOTE**

- 1) Dimensions are in millimeters. Weights are in kilograms (kg) and (pounds (lbs)).
- 2) Dimensions and weights of the servo motor may be revised without prior notice.
- 3) The boxes (□) in the model names are for optional configurations. (Please refer to section 1.2 for model explanation.)
- 4) Actual measured values are in metric units. Dimensions and weights in (imperial units) are for reference only.

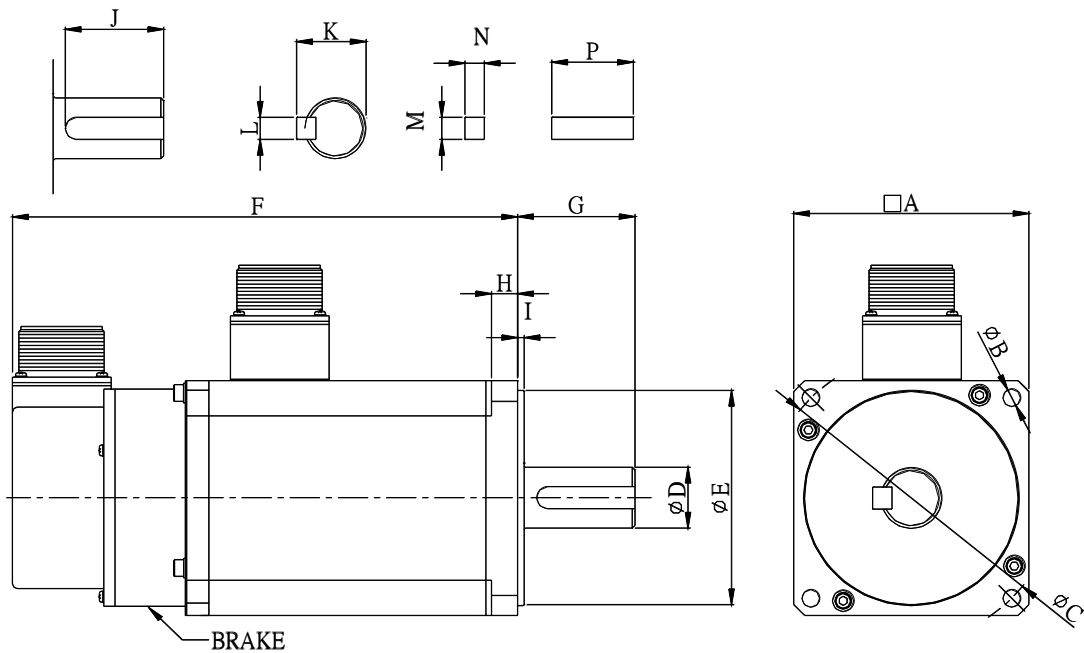
Chapter 11 Specifications | ASDA-A&A+ Series

Model	ASMT10L250□□	ASMT20L250□□	ASMT30L250□□
A	100	100	130
B	9	9	9
C	115 +0.2 -0.2	115 +0.2 -0.2	145 +0.2 -0.2
D	22h6 +0.0 -0.013	22h6 +0.0 -0.013	24h6 +0.0 -0.013
E	95h7 +0.0 -0.035	95h7 +0.0 -0.035	110h7 +0.0 -0.035
F (without brake)	158	194	173
F (with brake)	190	226	211
G	45	55	55
H	17	17	15
I	7	7	4
J	34	44	44
K	25 +0.0 -0.2	25 +0.0 -0.2	27 +0.0 -0.2
L	8h9 +0.0-0.036	8h9 +0.0 -0.036	8h9 -0.0-0.036
M	8	8	8
N	7	7	7
P	30	40	40
Weight (without brake)	4.7 (10.36)	6.7 (12.57)	8.0 (17.64)
Weight (with brake)	6.3 (13.89)	8.3 (16.09)	10.7 (23.59)

 **NOTE**

- 1) Dimensions are in millimeters. Weights are in kilograms (kg) and (pounds (lbs)).
- 2) Dimensions and weights of the servo motor may be revised without prior notice.
- 3) The boxes (□) in the model names are for optional configurations. (Please refer to section 1.2 for model explanation.)
- 4) Actual measured values are in metric units. Dimensions and weights in (imperial units) are for reference only.

Chapter 11 Specifications | ASDA-A&A+ Series

11.10 Dimensions of Medium Inertia Servo Motor (ASMT□□M Series)

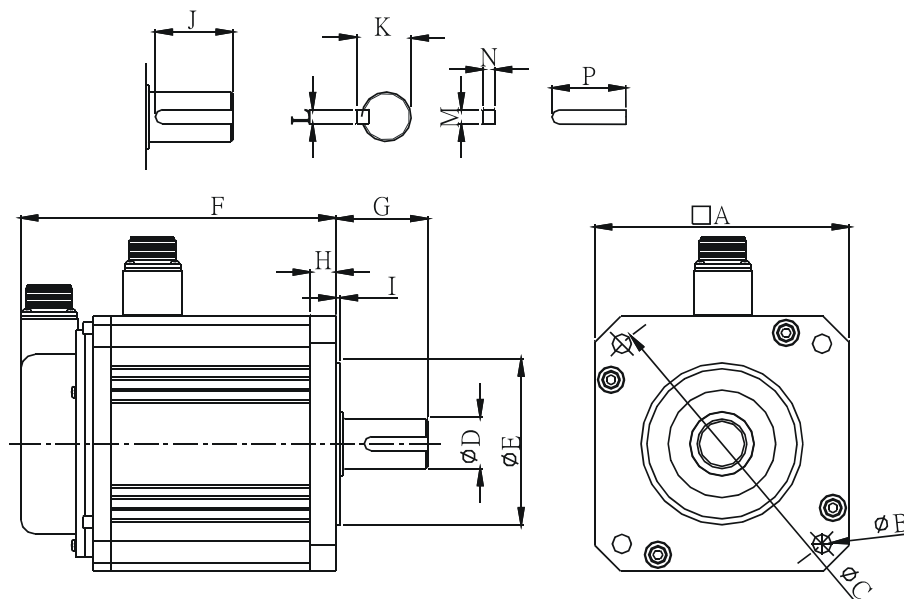

Model	ASMT10M250□□	ASMT15M250□□	ASMT20M250□□	ASMT30M250□□
A	130	130	180	180
B	9	9	13.5	13.5
C	145 +0.2 -0.2	145 +0.2 -0.2	200 +0.2 -0.2	200 +0.2 -0.2
D	22h6 +0.0 -0.013	22h6 +0.0 -0.013	35h6 +0.0 -0.016	35h6 +0.0 -0.016
E	110h7 +0.0 -0.035	110h7 +0.0 -0.035	114.3h7 +0 -0.035	114.3h7 +0 -0.035
F (without brake)	143	158	164	212
F (with brake)	181	196	213	258
G	55	55	75	75
H	15	15	20	20
I	4	4	4	4
J	44	44	65	65
K	25 +0.0 -0.1	25 +0.0 -0.1	38 +0.0 -0.2	38+0.0 -0.2
L	8h9 +0.0 -0.036	8h9 +0.0 -0.036	10h9 +0.0 -0.036	10h9 +0.0 -0.036
M	8	8	10	10
N	7	7	8	8
P	40	40	60	60
Weight (without brake)	4.8 (10.58)	7.0 (15.43)	12.0 (26.46)	17.0 (37.48)
Weight (with brake)	7.5 (16.53)	9.7 (21.38)	19.0 (41.89)	24.0 (52.91)

 **NOTE**

- 1) Dimensions are in millimeters. Weights are in kilograms (kg) and (pounds (lbs)).
- 2) Dimensions and weights of the servo motor may be revised without prior notice.
- 3) The boxes (□) in the model names are for optional configurations. (Please refer to section 1.2 for model explanation.)
- 4) Actual measured values are in metric units. Dimensions and weights in (imperial units) are for reference only.

Chapter 11 Specifications | ASDA-A&A+ Series

11.11 Dimensions of Medium / High Inertia Servo Motor (ECMA Series)

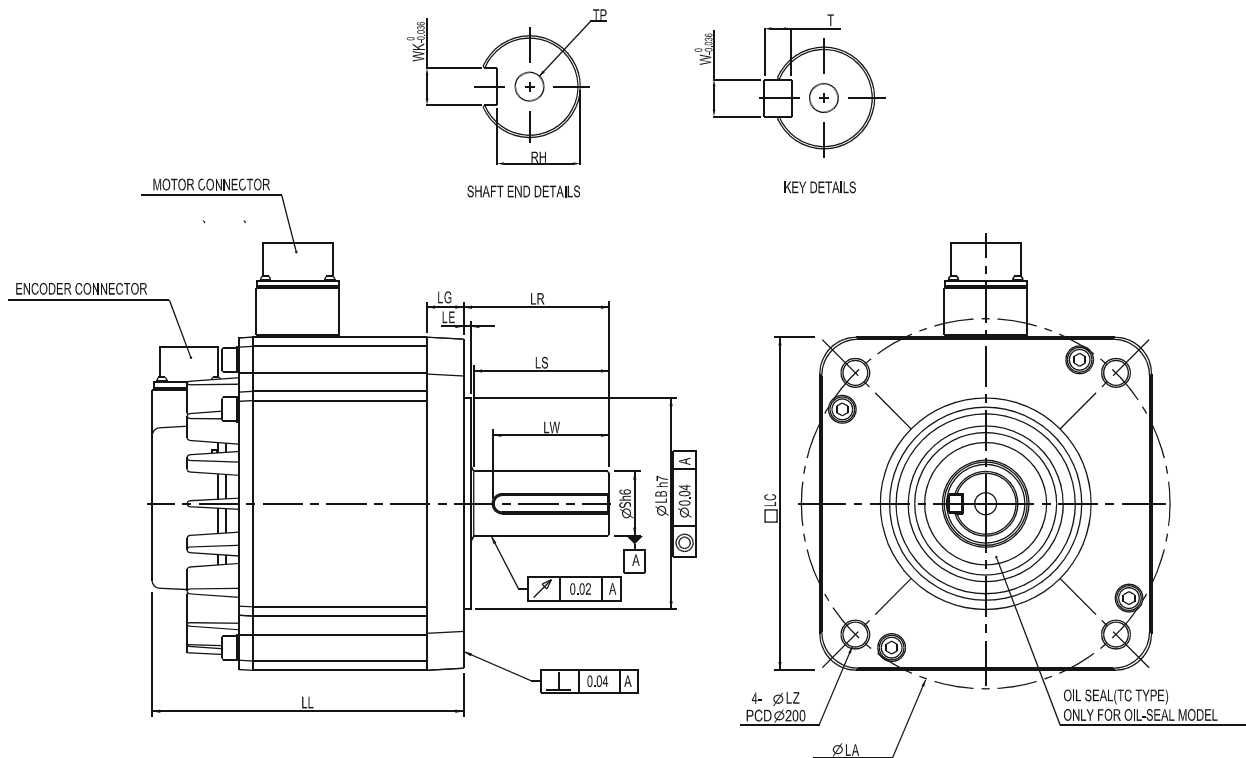

Model	ECMA-F21830□S	ECMA-E21835□S	ECMA-F21845□S
LC	180	180	180
LZ	13.5	13.5	13.5
LA	200	200	200
S	35	35	35
LB	114.3	114.3	114.3
LL	202.1	202.1	235.3
LR	79	79	79
LE	4	4	4
LG	20	20	20
LS	73	73	73
LW	63	63	63
RH	30	30	30
WK	10	10	10
W	10	10	10
T	8	8	8
TP	M12, Depth25	M12, Depth25	M12, Depth25
Weight (without brake)	18.5 (40.79)	18.5 (40.79)	23.5 (51.81)
Weight (with brake)	22.5 (49.6)	22.5 (49.6)	27.5 (60.63)

Chapter 11 Specifications | ASDA-A&A+ Series

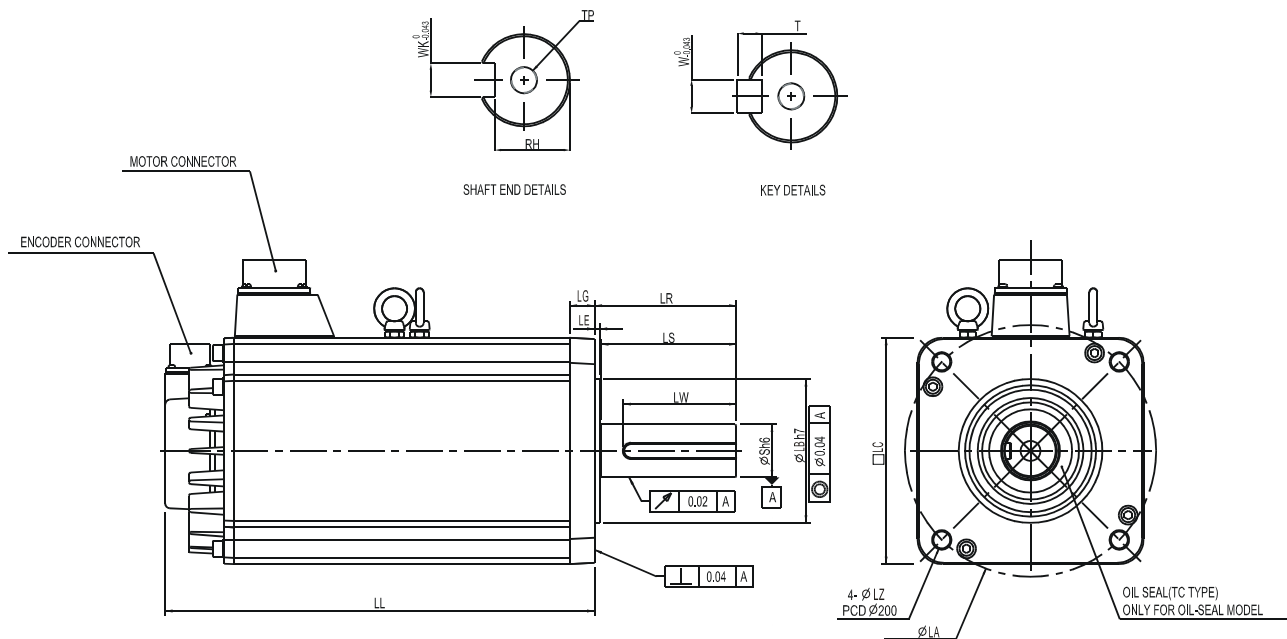

Model	ECMA-F21855□3	ECMA-F21875□3
LC	180	180
LZ	13.5	13.5
LA	200	200
S	42	42
LB	114.3	114.3
LL	279.7	342.0
LR	113	113
LE	4	4
LG	20	20
LS	108.5	108.5
LW	90	90
RH	37	37
WK	12	12
W	12	12
T	8	8
TP	M16, Depth32	M16, Depth32
Weight (without brake)	30.5 (67.24)	37.0 (81.57)
Weight (with brake)	36.0 (79.37)	47 (103.62)

 **NOTE**

- 1) Dimensions are in millimeters. Weights are in kilograms (kg) and (pounds (lbs)).
- 2) Dimensions and weights of the servo motor may be revised without prior notice.
- 3) The boxes (□) in the model names are for optional configurations. (Please refer to section 1.2 for model explanation.)
- 4) Actual measured values are in metric units. Dimensions and weights in (imperial units) are for reference only.

Chapter 11 Specifications | ASDA-A&A+ Series

This page intentionally left blank.

Chapter 12 Application Examples

12.1 Position Control (including homing function)

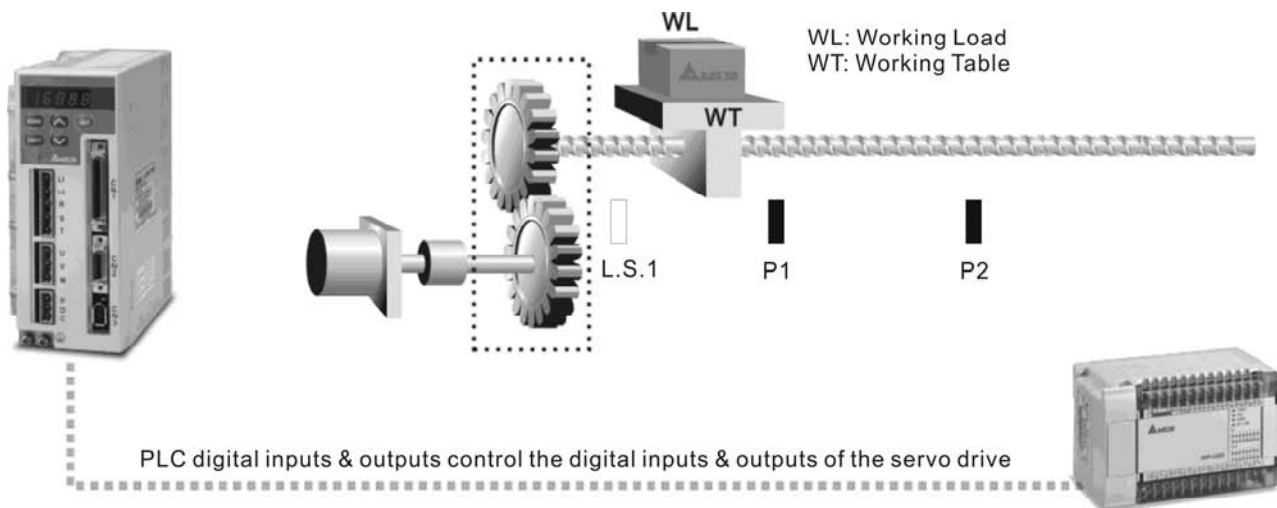

Suppose that the machine will move to limit switch (CCWL), L.S.1 when motor is in forward rotation (from motor shaft view) and the machine will move to limit switch (CWL), L.S.2 when motor is in reverse rotation, if limit switch is set, L.S.1 as “Home”, the machine will be positioned between P1 and P2 according to working procedure.

Parameters Setting

- P1-01=1 (Position control (Pr) mode setting)
- P1-47=100 (Activate forward homing)
- P2-15=022 (Reverse inhibit limit (CWL). Then, connect contact “b” of L.S.1 to DI6)
- P2-16=023 (Forward inhibit limit (CCWL). Then, connect contact “b” of L.S.2 to DI7)
- P2-10=101 (Servo On (SON), default: DI1)
- P2-11=108 (Command triggered (CTRG), default: DI2)
- P2-12=111 (Position command selection (POS0), default: DI3)
- P1-33=0 (Absolute position command)
- Set P1-15, P1-16 as position P1 (Internal position command 1)
- Set P1-17, P1-18 as position P2 (Internal position command 2)
- P2-18=101 (Servo ready (SRDY), default: DO1)
- P2-21=105 (Positioning completed (TPOS), default: DO4)
- P2-20=109 (Home completed (HOME), default: DO3)
- P1-50=0, P1-51=0 (Homing offset rotation / pulse number)

Chapter 12 Application Examples | ASDA-A&A+ Series

- Other relevant parameters: P1-34, P1-35, P1-36 (Acceleration/Deceleration time setting); P1-48, P1-49 (Speed setting of high/low speed Homing)

Operation

- Re-start the power to be ON again.
- After Servo ready is completed, activate the drive to be Servo ON. Then, the system will automatically complete home operation.
- When home operation is completed (Home ready), then can perform the position control function.

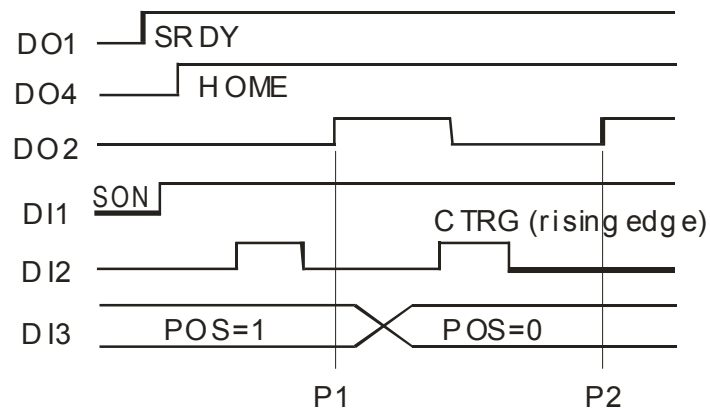

Chapter 12 Application Examples | ASDA-A&A+ Series

12.2 Roller Feeding

Suppose that the motor rotate 1/4 rev. while it is triggered every time ($10000/4=2500$ Pulse).



Parameters Setting

- P1-01=1 (Position control (Pr) mode setting)
- P2-10=101 (Servo On (SON), default: DI1)
- P2-11=108 (Command triggered (CTRG), default: DI2)
- P1-15=0 (Position rotation number is 0(zero))
- P1-16=2500 (Position rotation pulse number)
- P1-33=1 (Incremental position command)
- P2-18=101 (Servo ready (SRDY), default: DO1)
- P2-21=105 (Positioning completed (TPOS), default: DO4)
- Other relevant parameters: P1-34, P1-35, P1-36 (Acceleration/Deceleration time setting)

Operation

- Re-start the power to be ON again.
- After Servo ready is completed, press the Servo ON key and activate the drive to be Servo ON.
- After DI2 is triggered, the motor will rotate 1/4rev automatically.

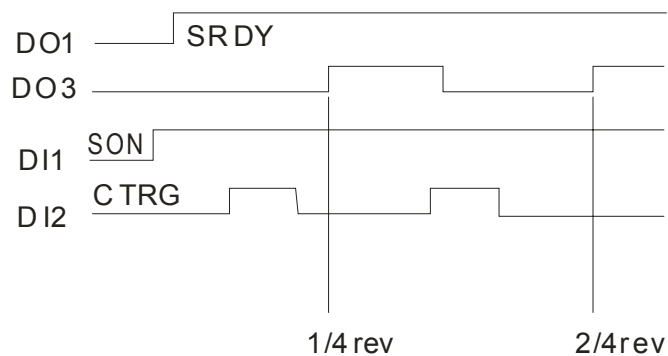

Chapter 12 Application Examples | ASDA-A&A+ Series

12.3 Connecting to Delta DVP-EH Series PLC

Delta servo drives can be connected to Delta DVP-EH series PLC and provide functions including: home, JOG operation, acceleration/deceleration setting, relative position control, absolute position control and pulse numbers monitor.

DVP-EH Series PLC

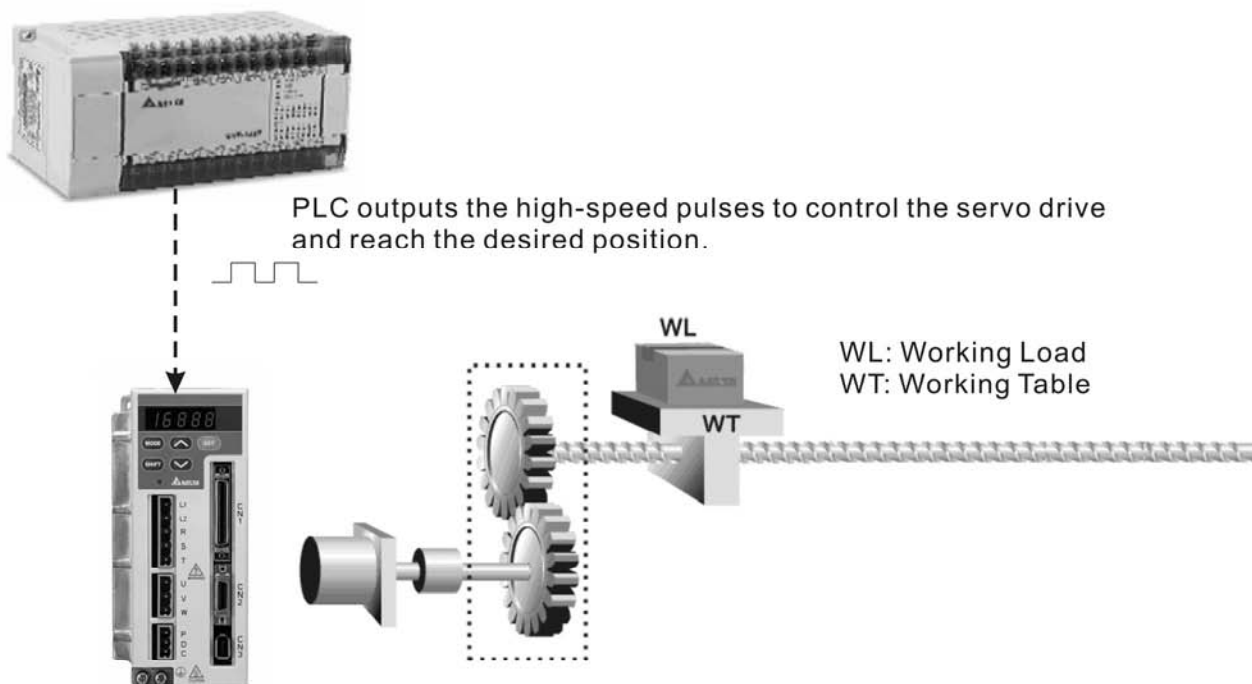

Parameters Setting

- P1-00=2 (Input type setting of external pulse, 2: pulse input + direction)
- P1-01=0 (Position control (Pt) mode setting)
- P2-10=101 (Servo On (SON), default: DI1)
- P2-11=104 (Pulse count clear function, contact: DI2)
- P2-15=102 (Fault reset, contact: DI5)
- Other relevant parameters: P1-34, P1-35, P1-36 (Acceleration/Deceleration time setting)

Operation

- Re-start the power to be ON again.
- After Servo ready is completed, activate the drive to be Servo ON.
- Connect contact X1 of PLC (drive X1 to be ON) to perform home operation. When contact X10 is ON, home operation is completed.
- PLC X2 : JOG forward operation ; PLC X3 : JOG reverse operation.
- After home operation is completed, connect contact X5 of PLC (drive X5 to be ON) and the absolute coordinate position will be 10000. Then, connect contact X4 of PLC (drive X4 to be ON) and the absolute coordinate position will be 0.

Chapter 12 Application Examples | ASDA-A&A+ Series

- Repeat this position control operation.

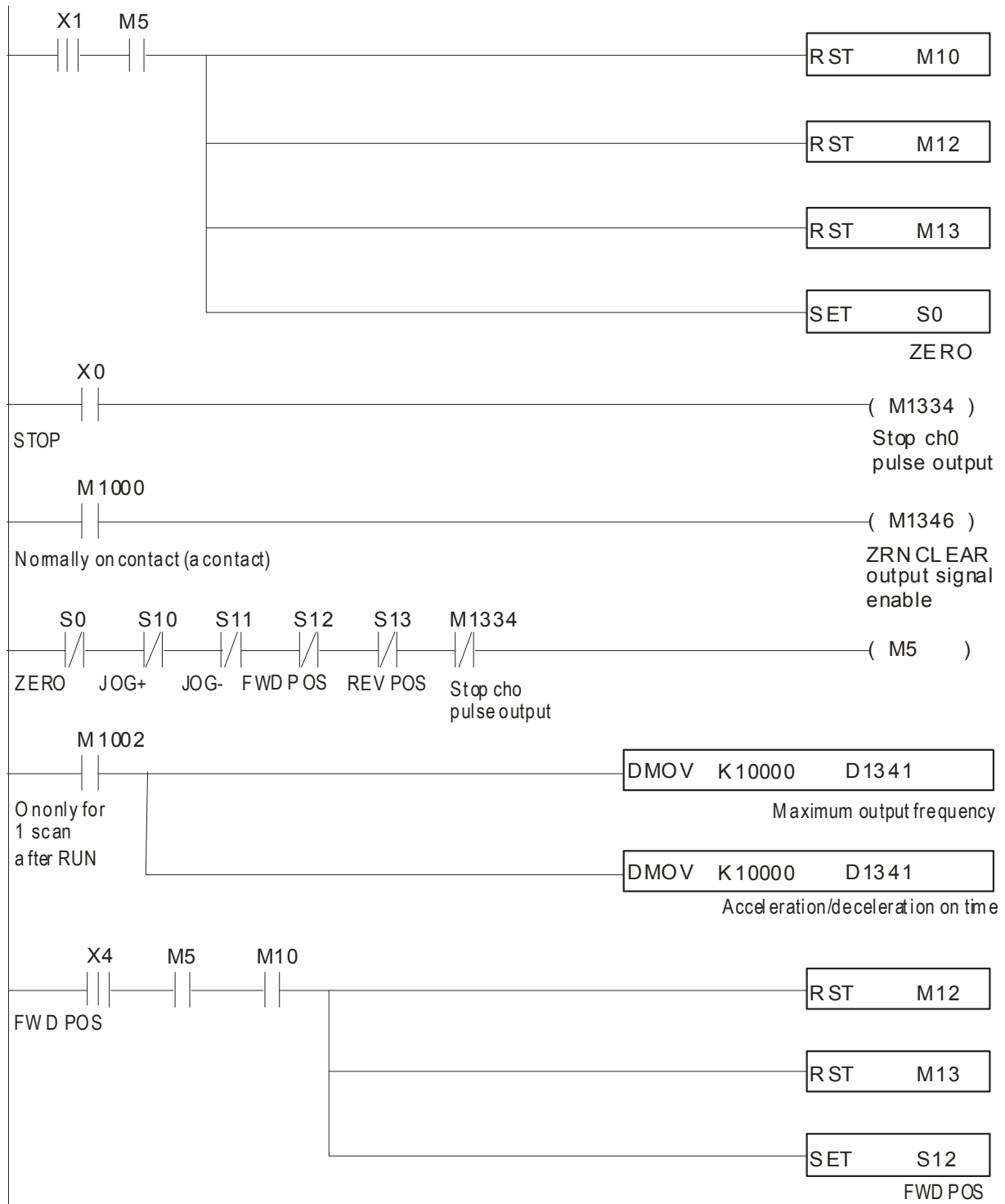

Chapter 12 Application Examples | ASDA-A&A+ Series

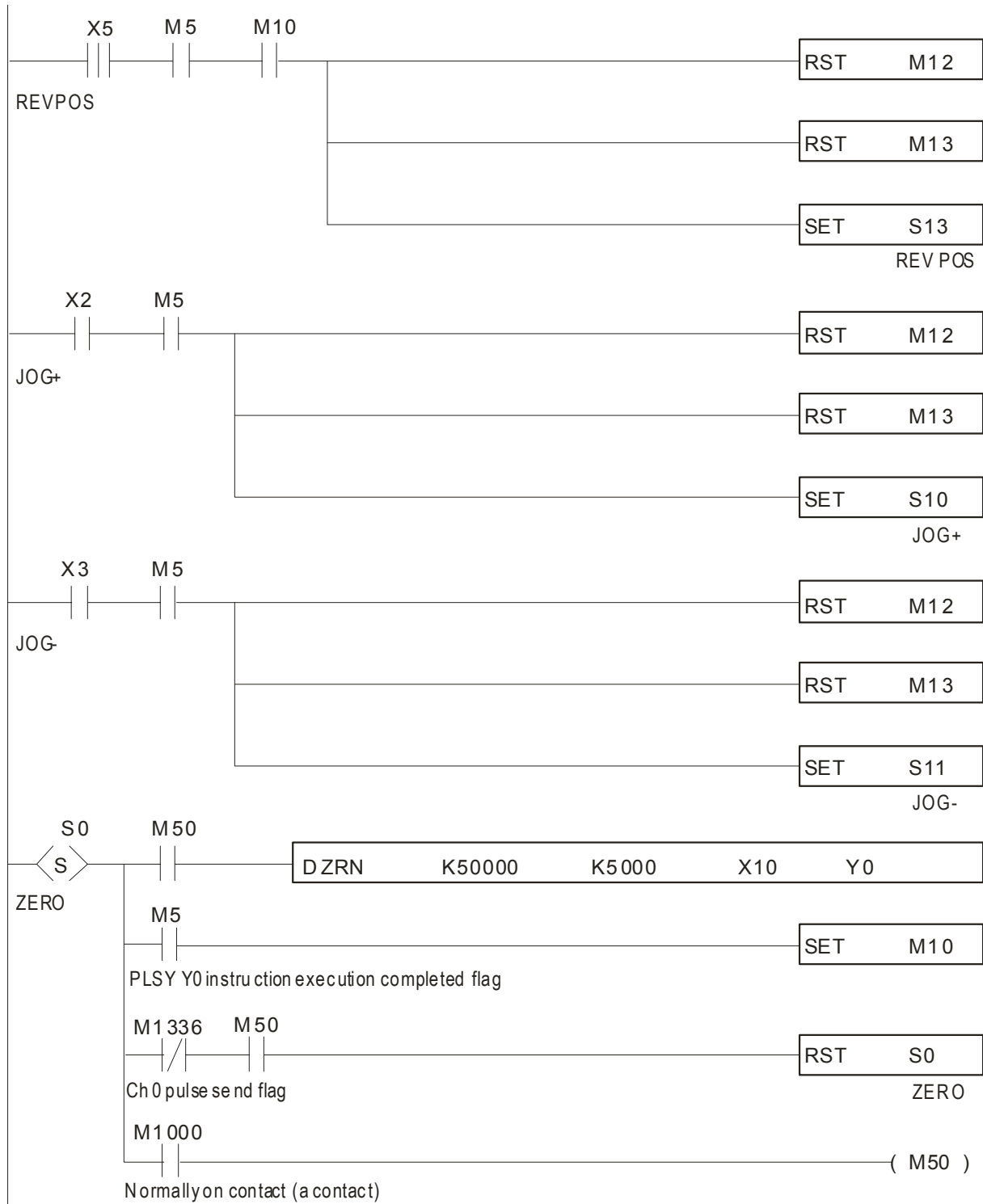

Chapter 12 Application Examples | ASDA-A&A+ Series

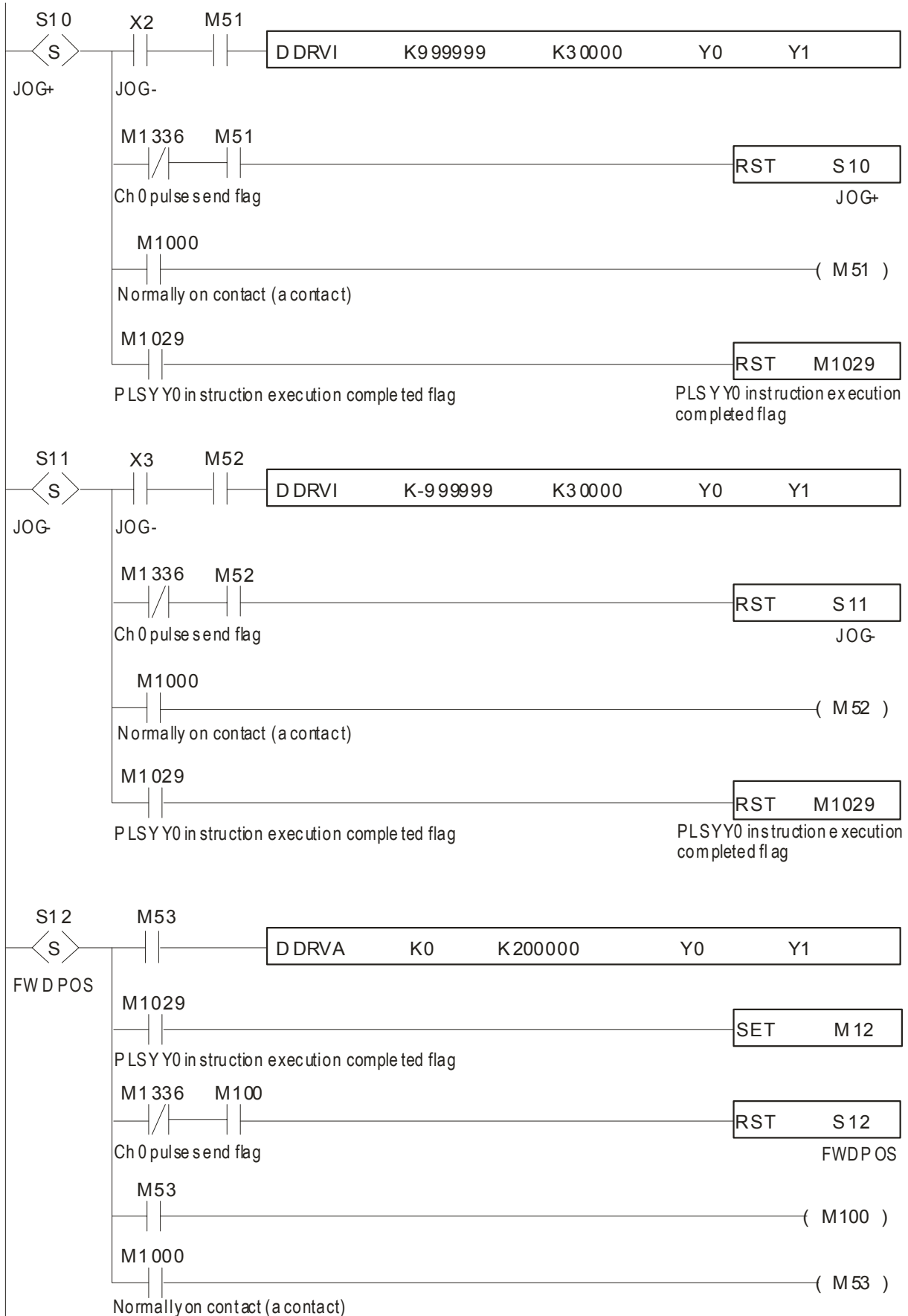

Chapter 12 Application Examples | ASDA-A&A+ Series

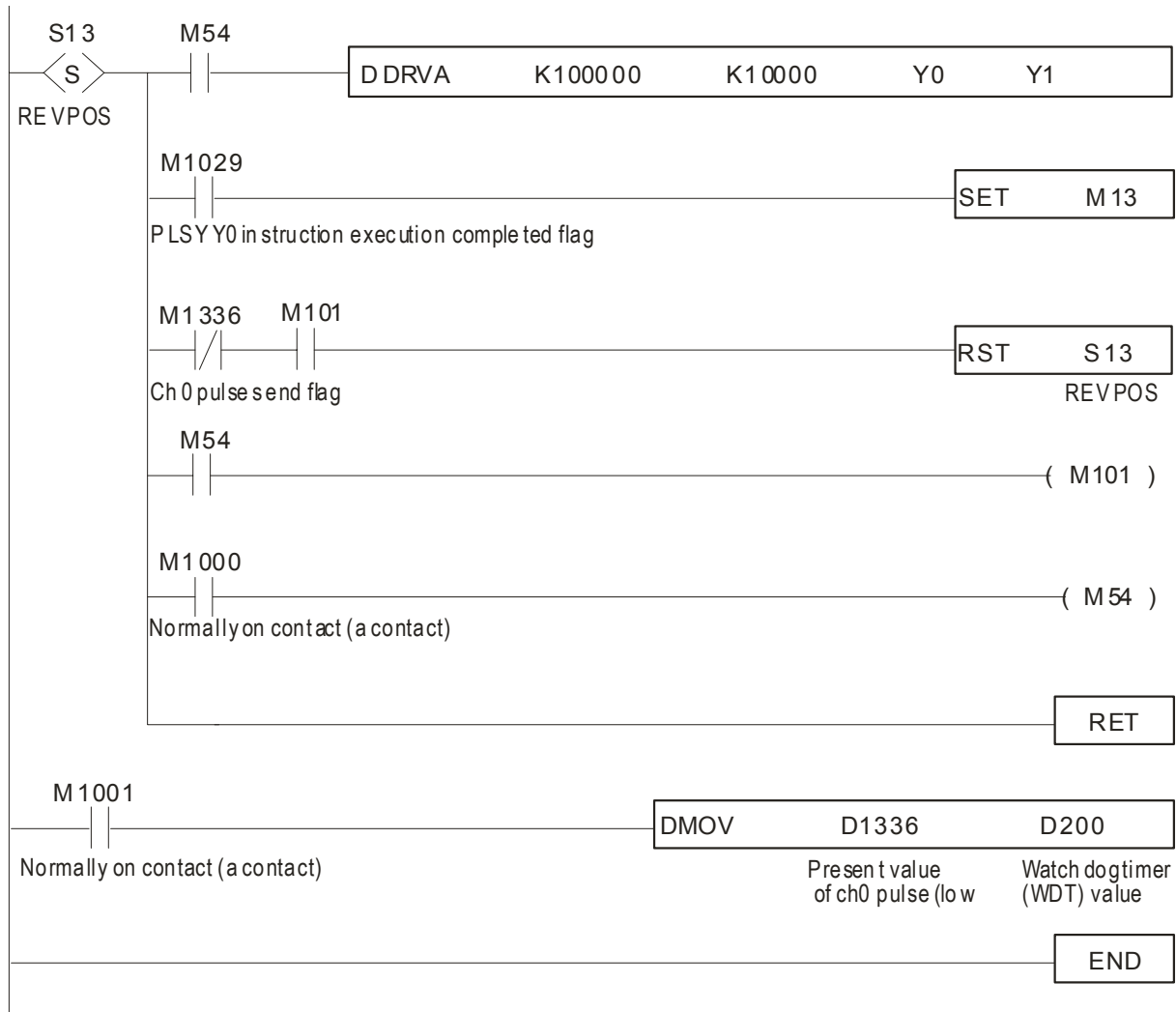

Chapter 12 Application Examples | ASDA-A&A+ Series

12.4 Connecting to Delta TP04 Series

Delta servo drives can be connected to Delta TP04 Series Operation Interface Panel and provide functions including: Home, JOG operation, Position learning function, Relative position control, Absolute position control, Monitor and parameter settings.



Parameters Setting

- P1-01=1 (Position control (Pr) mode setting)
- P1-47=202 (SHOM drive ORGP to perform forward homing)
- P2-15=124 (Home detection position, contact: DI6)
- P2-16=127 (Activate signal of home, contact: DI7)
- P2-10=101 (Servo On (SON), default: DI1)
- P2-11=108 (Command triggered (CTRG), default: DI2)
- P2-12=111 (Position command selection (POS0), default: DI3)
- P2-13=112 (Position command selection (POS1), default: DI4)
- P3-02=1 (Communication protocol 7,E,1)
- P3-05=2 (RS-485 serial communication)

Operation

- Re-start the power to be ON again.
- After Servo ready is completed, press the Servo ON key and activate the drive to be Servo ON.

Chapter 12 Application Examples | ASDA-A&A+ Series

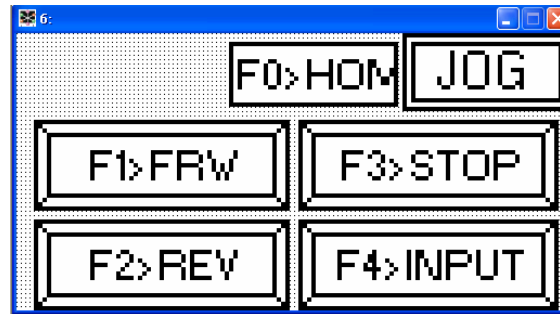
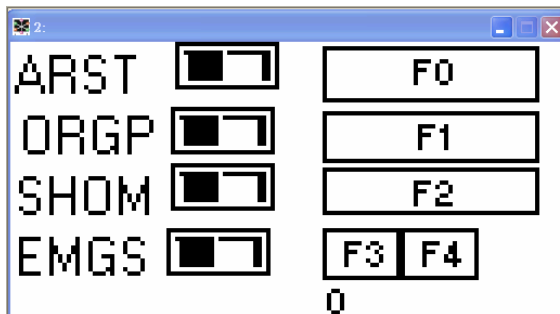
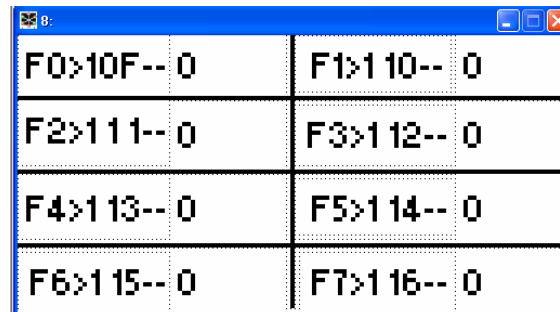
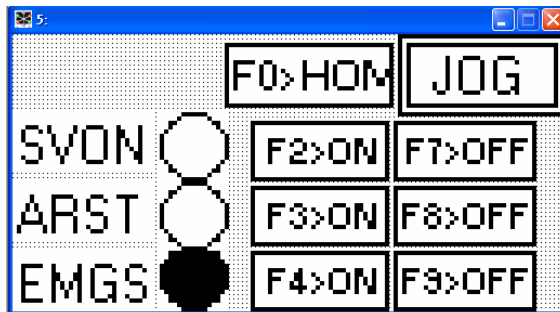
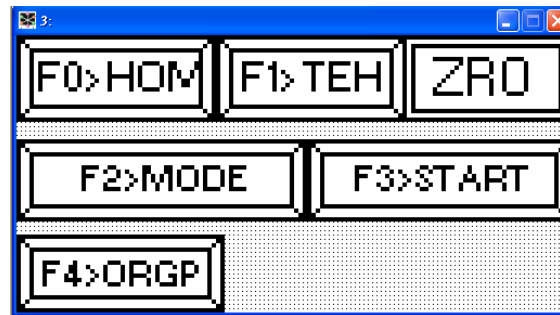
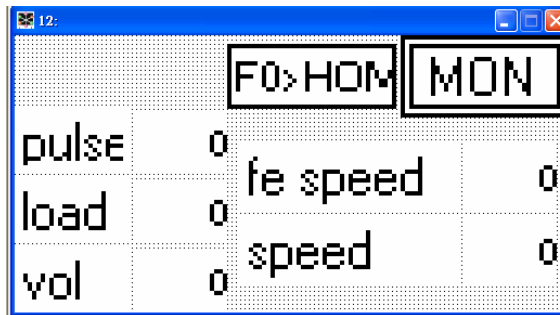
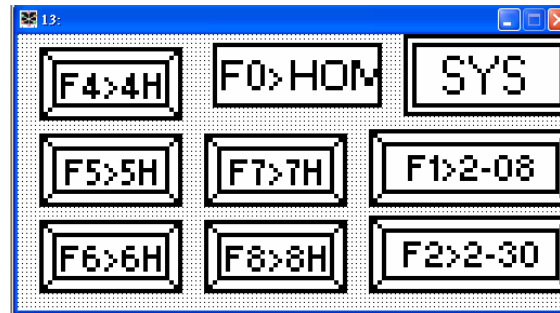
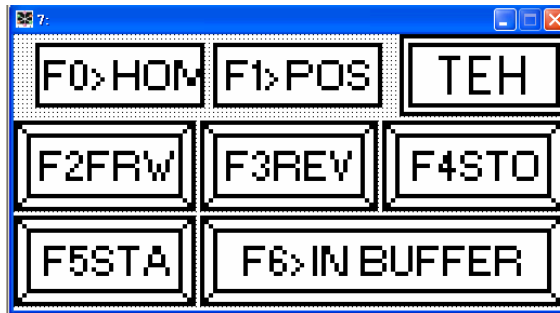
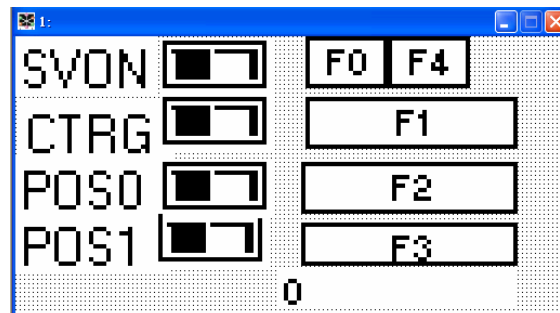

Chapter 12 Application Examples | ASDA-A&A+ Series

12.5 Position Control Mode (Pr Mode)

■ Relevant Parameters Description

Parameter	Communication Address	Parameter Description
P1-01	0101H	Control Mode and Output Direction 001: Forward torque in Pr mode 101: Reverse torque in Pr mode
P1-33	0121H	Position Control Mode (Pr) 0: Absolute position command 1: Incremental position command
P1-34	0122H	Acceleration Time 1st to 3rd step Acceleration time (When parameter P1-36 is set to 0, accel / decel function is disabled, i.e. P1-34, P1-35 is disabled)
P1-35	0123H	Deceleration Time 1st to 3rd step Deceleration time (When parameter P1-36 is set to 0, accel / decel function is disabled, i.e. P1-34, P1-35 is disabled)
P1-36	0124H	Accel /Decel S-curve When parameter P1-36 is set to 0, accel / decel function is disabled, i.e. P1-34, P1-35 is disabled.
P1-44	012CH	Electronic Gear Ratio (1st Numerator) (N1) If the electronic gear deceleration ratio is 1/75, set numerator to 75
P1-45	012DH	Electronic Gear Ratio (Denominator)
P1-47	012FH	Homing Mode 202: When (MD1, MD0)=(OFF, ON), Forward Homing 203: When (MD1, MD0)=(OFF, ON), Reverse Homing
P1-50	0132H	Homing Offset Rotation Number
P1-51	0133H	Homing Offset Pulse Number Total homing offset pulse number =P1-50 x 10000 + P1-51

The following table indicates the position command registers and the corresponding moving speed registers.

Positioning Point	Position Command Register	Moving Speed Register
P1	(P1-15, P1-16)	P2-36 (V1)
P2	(P1-17, P1-18)	P2-37 (V2)
P3	(P1-19, P1-20)	P2-38 (V3)
P4	(P1-21, P1-22)	P2-39 (V4)
P5	(P1-23, P1-24)	P2-40 (V5)
P6	(P1-25, P1-26)	P2-41 (V6)
P7	(P1-27, P1-28)	P2-42 (V7)
P8	(P1-29, P1-30)	P2-43 (V8)

Chapter 12 Application Examples | ASDA-A&A+ Series

■ Trigger Timing Charts

(1) Timing Chart of Internal Position Register Selection

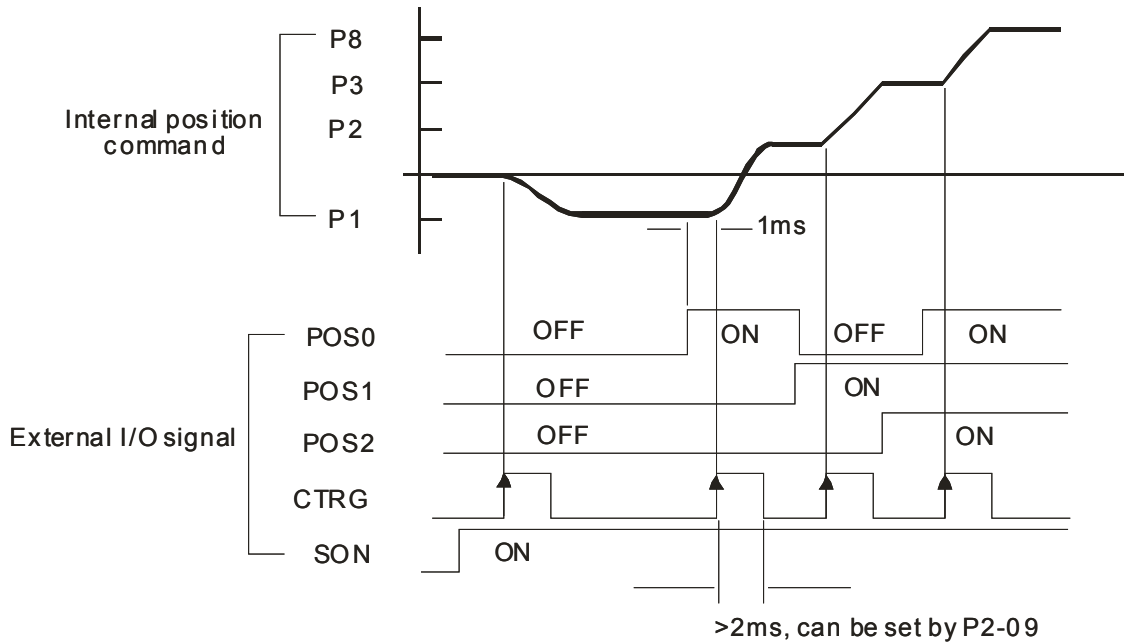

(2) HOLD Timing Chart:

If HOLD signal is ON when the motor is running, the motor will decelerate first and stop according to the deceleration time which is set by parameter P1-34 ~ P1-36. When TRIG signal is ON again, the motor will continue to move across the remaining pulses. Then, reach the target position that is set last time.

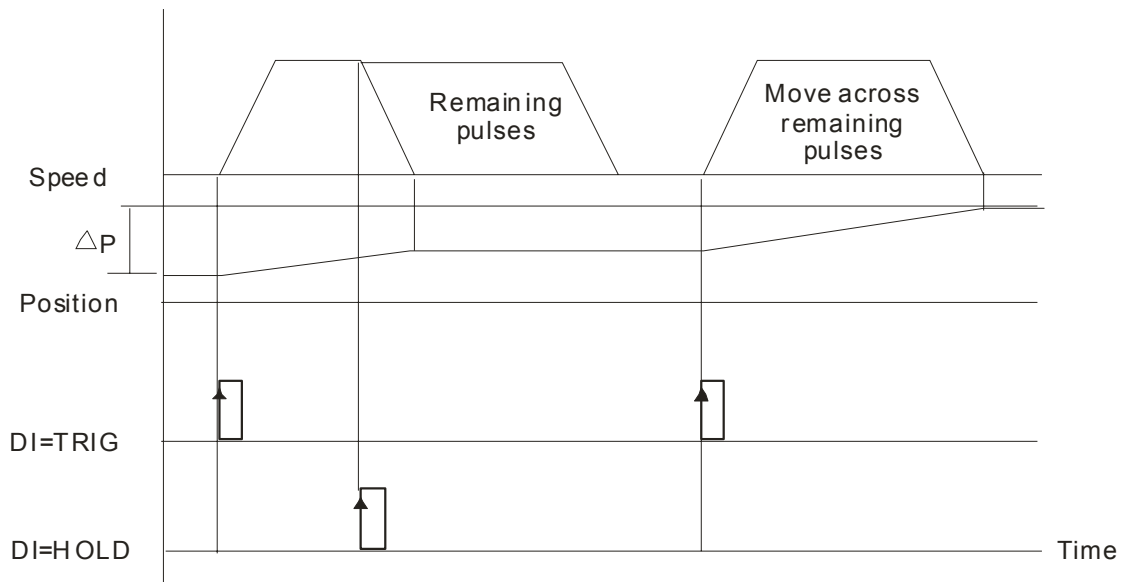

Chapter 12 Application Examples | ASDA-A&A+ Series**(3) Command Abort Timing Chart:**

To use command abort function, set parameter P2-50 to 2. At this time, if CCLR signal is ON when the motor is running, the motor will decelerate first and stop according to the deceleration time which is set by parameter P1-34 ~ P1-36 and the remaining pulses will be aborted. When TRIG signal is ON again, the motor will continue to move forward and reach the target position that is set currently.

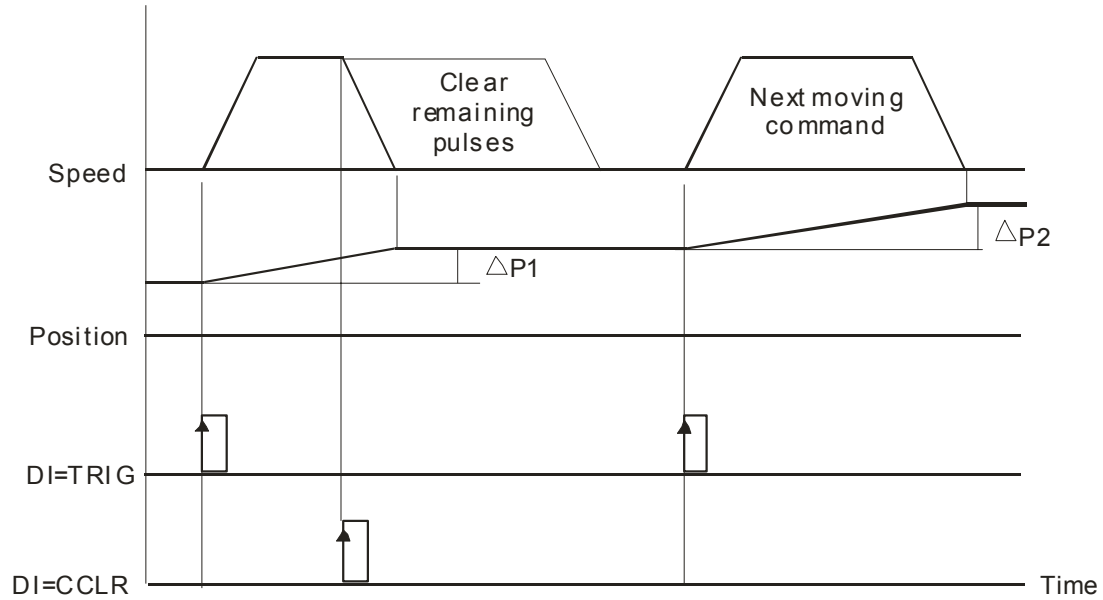

Chapter 12 Application Examples | ASDA-A&A+ Series

12.6 Feed Step Control

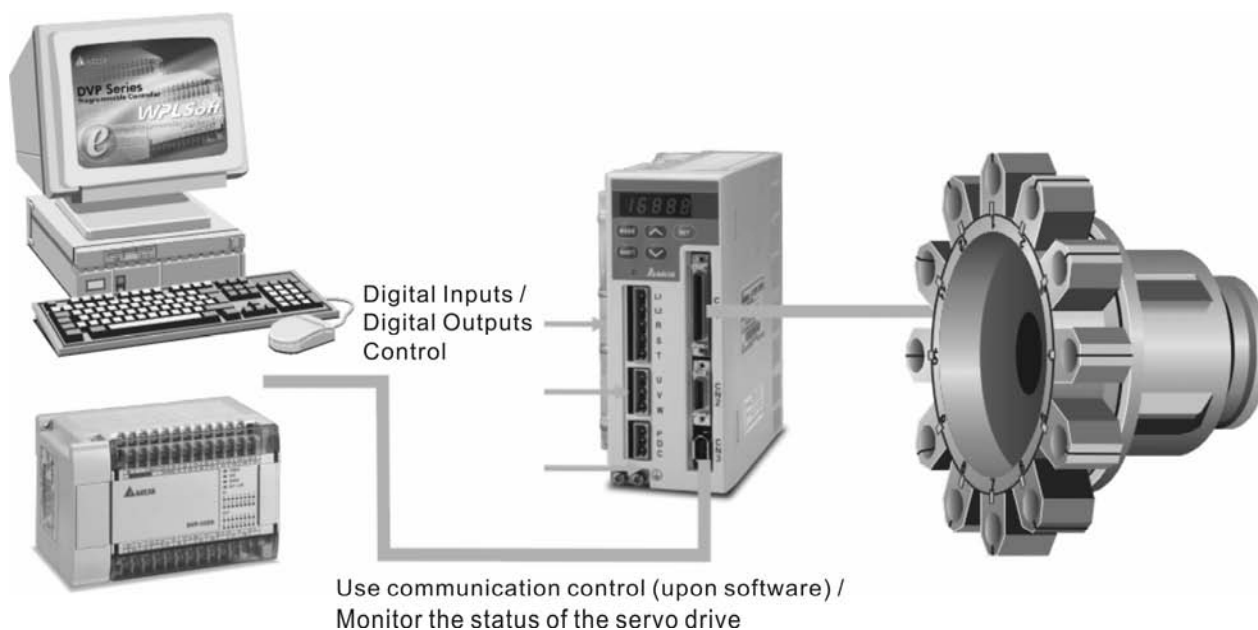

■ Relevant Parameters Description

Parameter	Communication Address	Parameter Description
P1-01	0101H	Control Mode and Output Direction 001: Forward torque in Pr mode 101: Reverse torque in Pr mode
P1-12	010CH	Torque Limit Setting Torque decrease value is represented by a percentage of rated torque.
P1-33	0121H	Position Control Mode (Pr) 2: Forward operation search feed step 3: Reverse operation search feed step 4: Short-pass search feed step
P1-34	0122H	Acceleration Time 1st to 3rd step Acceleration time (When parameter P1-36 is set to 0, accel / decel function is disabled, i.e. P1-34, P1-35 is disabled)
P1-35	0123H	Deceleration Time 1st to 3rd step Deceleration time (When parameter P1-36 is set to 0, accel / decel function is disabled, i.e. P1-34, P1-35 is disabled)
P1-36	0124H	Accel /Decel S-curve When parameter P1-36 is set to 0, accel / decel function is disabled, i.e. P1-34, P1-35 is disabled.
P1-44	012CH	Electronic Gear Ratio (1st Numerator) (N1) If the electronic gear deceleration ratio is 1/75, set numerator to 75
P1-45	012DH	Electronic Gear Ratio (Denominator)
P1-47	012FH	Homing Mode 202: When (MD1, MD0)=(OFF, ON), Forward Homing 203: When (MD1, MD0)=(OFF, ON), Reverse Homing

Chapter 12 Application Examples | ASDA-A&A+ Series

Parameter	Communication Address	Parameter Description
P1-50	0132H	Homing Offset Rotation Number
P1-51	0133H	Homing Offset Pulse Number Total homing offset pulse number =P1-50 x 10000 + P1-51
P1-55	0137H	Maximum Speed Limit
P2-36	0224H	Moving Speed Setting of 1st Position Maximum feed step speed (When speed is above 3000r/min, please set P1-55 to a proper value)
P2-44	022CH	Digital Output Mode Setting 0: General output mode 1: Combination output mode

■ **Relevant Parameters Description, cont.**

Parameter	Communication Address	Parameter Description
P2-45	022DH	Combination Output Signal Delay Time [UNIT: 4msec] Output signal will hold delay time when position command is completed.
P2-46	022EH	Feed Step Number Range: 2~32
P2-47	022FH	Position Deviation Clear Delay Time [UNIT: 20msec] This function is disabled when its setting value is set to 0.
P2-51	0233H	Internal Servo ON setting

■ **Digital I/O Signal Setting**

DI Signal	Parameter Setting	Explanation
DI1 (INDEX0)	P2-10 = 128	Feed step selection input 0
DI2 (INDEX1)	P2-11 = 129	Feed step selection input 1
DI3 (INDEX2)	P2-12 = 130	Feed step selection input 2
DI4 (INDEX3)	P2-13 = 131	Feed step selection input 3
DI5 (ORGP)	P2-14 = 124	Reference "Home" sensor
DI6 (SON)	P2-15 = 101	Servo ON (when the setting value is 137, it is manual operation function.)
(MDP0)	P2-15 = 35 (contact "b")	Manually continuous operation
(MDP1)	P2-15 = 36 (contact "b")	Manually single step operation
DI7 (MD0)	P2-16 = 33 (contact "b")	Feed step mode input 0
DI8 (MD1)	P2-17 = 34 (contact "b")	Feed step mode input 1

Chapter 12 Application Examples | ASDA-A&A+ Series

DO Signal	Parameter Setting	Explanation
DO1	P2-18 = 101	Please refer to "Definition of DO Signals" in the following section.
DO2	P2-19 = 103	
DO3	P2-20 = 109	
DO4	P2-21 = 105	
DO5	P2-22 = 107	

 **NOTE**

- 1) Please set parameter P2-08 to 12 before changing the setting value of DI and DO signals.

Mode Functions

MDP0, MDP1	Status	MD1	MD0	Explanation
OFF	1	OFF	OFF	Torque decrease
	2	OFF	ON	Homing mode
	3	ON	OFF	Feed step position mode
	4	ON	ON	Emergency stop
ON	-	-	-	Don't care
	-	OFF	ON	CCW manual operation
	-	ON	OFF	CW manual operation
	-	-	-	Don't care

 **NOTE**

- 1) The emergency stop warning message will appear if MD0 and MD1 are ON after power suppliers to AC servo drive. If turn MD0 and MD1 to be OFF, the emergency stop warning message will disappear automatically.
- 2) When the status is switched from 3 (MD0=OFF, MD1=ON, Feed step position mode) to 2 (MD0=ON, MD1=OFF, Homing mode), the emergency stop warning message will appear. On the other hand, the emergency stop warning message will also appear when the status is switched from 2 to 3. Therefore, no matter what status you want to switch to, it is needed to switch to status 1 first to perform torque decrease (for example, switch from 2 → 1 → 3 or 3 → 1 → 2).
- 3) Ensure that MD0 and MD1 are set to ON state to enforce an emergency stop.

Chapter 12 Application Examples | ASDA-A&A+ Series**■ Definitions of INDEX0~4 (ON=1, OFF=0)**

Item	INDEX4	INDEX3	INDEX2	INDEX1	INDEX0	INDEX NUMBER
1	0	0	0	0	0	INDEX 1
2	0	0	0	0	1	INDEX 2
3	0	0	0	1	0	INDEX 3
4	0	0	0	1	1	INDEX 4
5	0	0	1	0	0	INDEX 5
6	0	0	1	0	1	INDEX 6
7	0	0	1	1	0	INDEX 7
8	0	0	1	1	1	INDEX 8
9	0	1	0	0	0	INDEX 9
10	0	1	0	0	1	INDEX 10
11	0	1	0	1	0	INDEX 11
12	0	1	0	1	1	INDEX 12
13	0	1	1	0	0	INDEX 13
14	0	1	1	0	1	INDEX 14
15	0	1	1	1	0	INDEX 15
16	0	1	1	1	1	INDEX 16
17	1	0	0	0	0	INDEX 17
18	1	0	0	0	1	INDEX 18
19	1	0	0	1	0	INDEX 19
20	1	0	0	1	1	INDEX 20
21	1	0	1	0	0	INDEX 21
22	1	0	1	0	1	INDEX 22
23	1	0	1	1	0	INDEX 23
24	1	0	1	1	1	INDEX 24
25	1	1	0	0	0	INDEX 25
26	1	1	0	0	1	INDEX 26
27	1	1	0	1	0	INDEX 27

Chapter 12 Application Examples | ASDA-A&A+ Series**■ Definitions of DO Signals (ON=1, OFF=0)**

Item	DO5	DO4	DO3	DO2	DO1	Description
1	0	0	0	0	0	ALRAM
2	0	0	0	0	1	SERVO READY
3	0	0	0	1	0	HOMING (under operation)
4	0	0	0	1	1	HOME Completed
5	0	0	1	0	0	CHANGE INDEX (under operation)
6	0	0	1	0	1	INDEX 1 (In position)
7	0	0	1	1	0	INDEX 2 (In position)
8	0	0	1	1	1	INDEX 3 (In position)
9	0	1	0	0	0	INDEX 4 (In position)
10	0	1	0	0	1	INDEX 5 (In position)
11	0	1	0	1	0	INDEX 6 (In position)
12	0	1	0	1	1	INDEX 7 (In position)
13	0	1	1	0	0	INDEX 8 (In position)
14	0	1	1	0	1	INDEX 9 (In position)
15	0	1	1	1	0	INDEX 10 (In position)
16	0	1	1	1	1	INDEX 11 (In position)
17	1	0	0	0	0	INDEX 12 (In position)
18	1	0	0	0	1	INDEX 13 (In position)
19	1	0	0	1	0	INDEX 14 (In position)
20	1	0	0	1	1	INDEX 15 (In position)
21	1	0	1	0	0	INDEX 16 (In position)
22	1	0	1	0	1	INDEX 17 (In position)
23	1	0	1	1	0	INDEX 18 (In position)
24	1	0	1	1	1	INDEX 19 (In position)
25	1	1	0	0	0	INDEX 20 (In position)
26	1	1	0	0	1	INDEX 21 (In position)
27	1	1	0	1	0	INDEX 22 (In position)
28	1	1	0	1	1	INDEX 23 (In position)
29	1	1	1	0	0	INDEX 24 (In position)
30	1	1	1	0	1	INDEX 25 (In position)
31	1	1	1	1	0	INDEX 26 (In position)
32	1	1	1	1	1	INDEX 27 (In position)

 NOTE

- 1) When alarm occurs, DO=0 (all OFF).
- 2) When the servo drive is ready, DO=1

Chapter 12 Application Examples | ASDA-A&A+ Series

- 3) When return back to "Home" (Homing), DO=2
- 4) When returning back to "Home" is completed, DO=3
- 5) When feed step function is undergoing, DO=4
- 6) When feed step function is completed (In position), the corresponding INDEX NUMBER will display, and DO=nn
- 7) Feed step output position = DO value - 4 (Example: if DO=7, the feed step output position = 7 - 4 = 3)
- 8) When returning to HOME, if DO=1 (SERVO READY) after any abnormal conditions are removed, it is recommended to return to HOME again to ensure that the "Home" is correct.

■ Timing charts of DI/DO Signals Operation

(1) Homing Mode

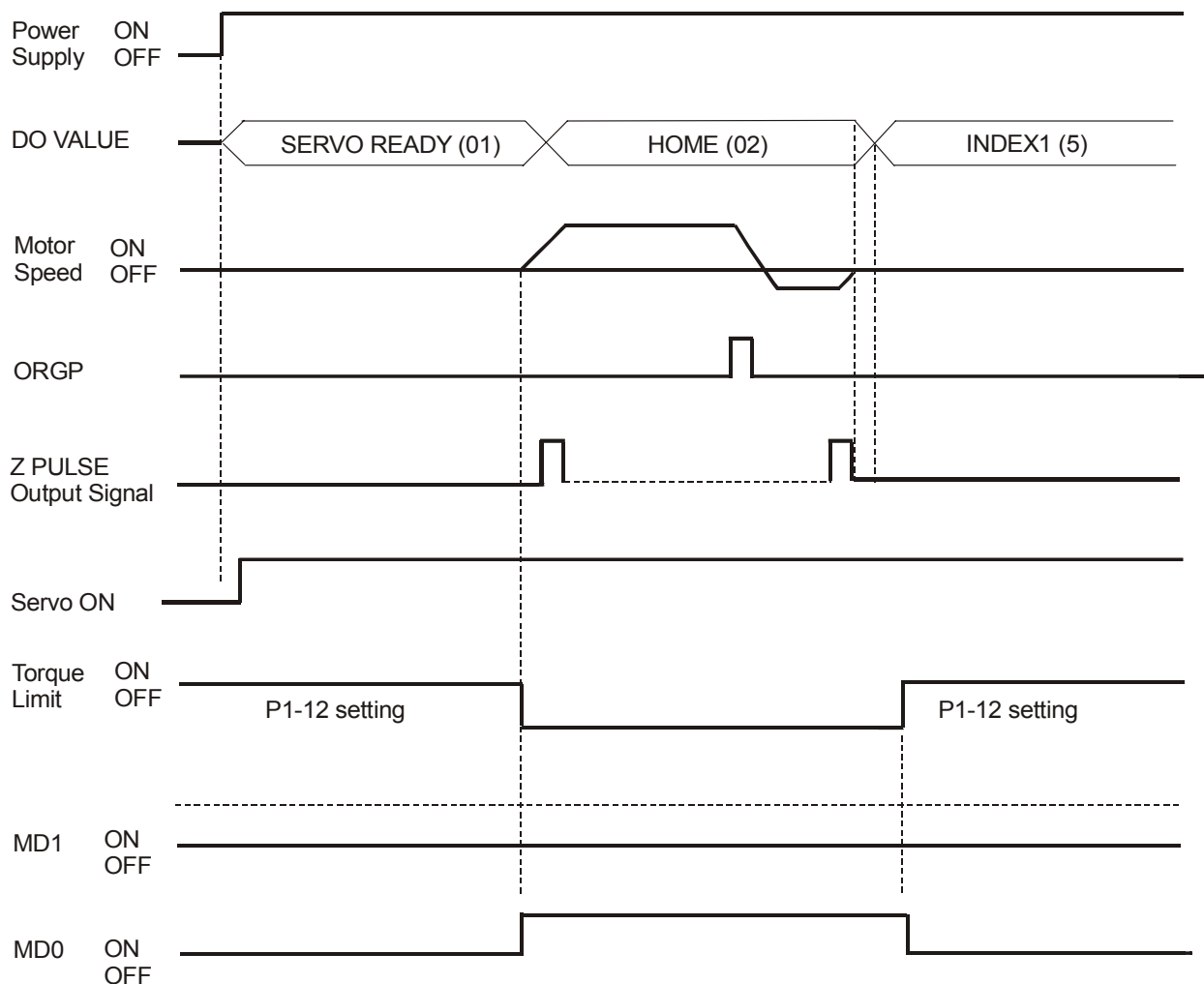

Chapter 12 Application Examples | ASDA-A&A+ Series

(2) Feed Step Control Mode

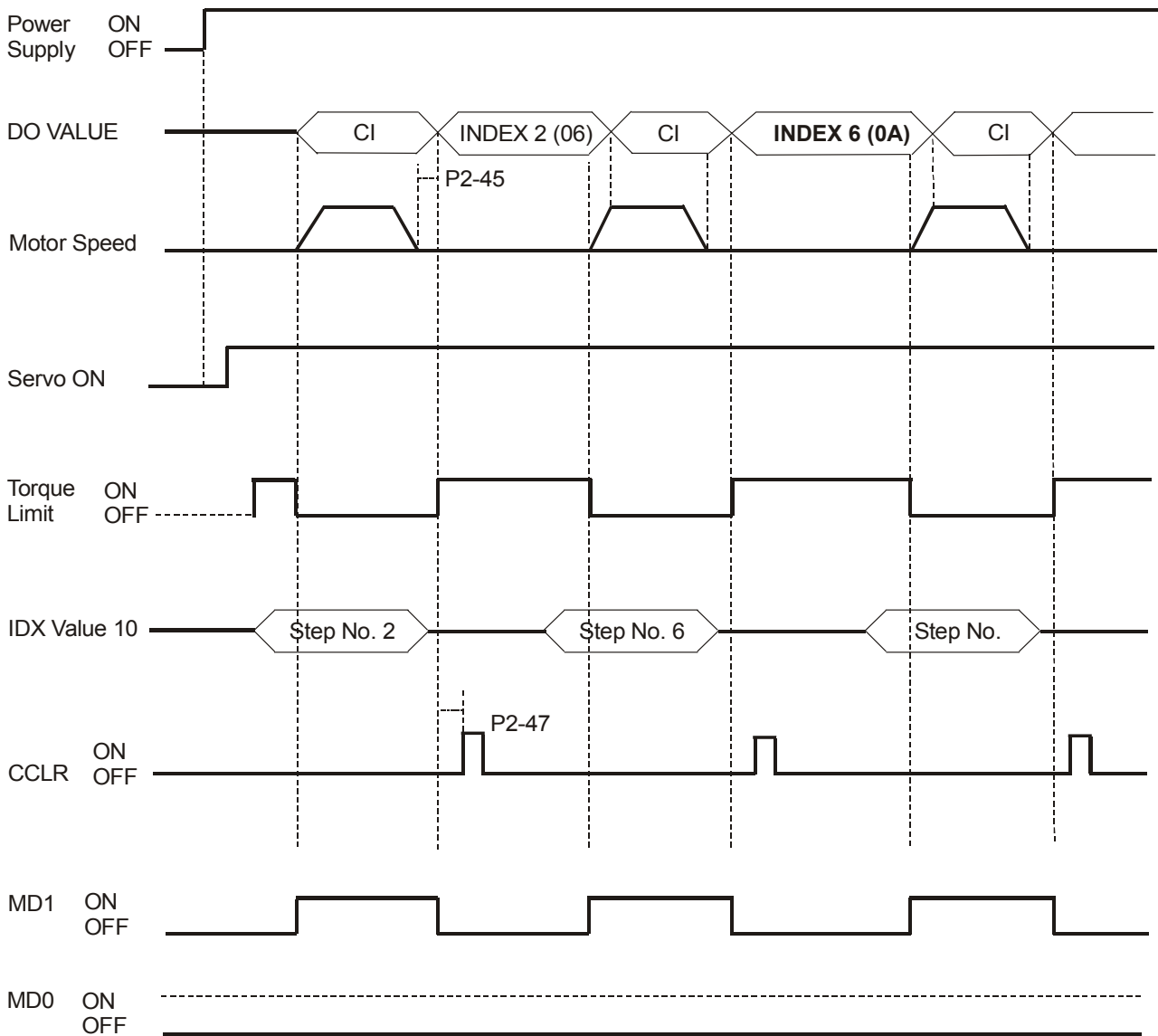

NOTE

- 1) The maximum value of P2-45 = $125 \times T \text{ min.}$
- 2) T min. is the minimum time from A to B, i.e. the time between when start running at A and when start running at B (please refer to the figure below). Time unit is 1 second.

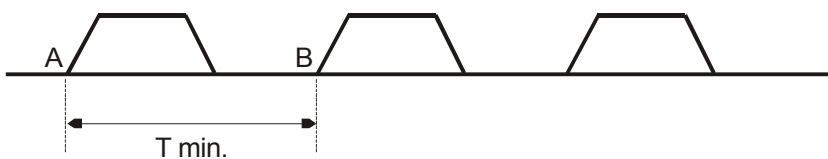

Chapter 12 Application Examples | ASDA-A&A+ Series

(3) Manually Single Step Control Mode 1

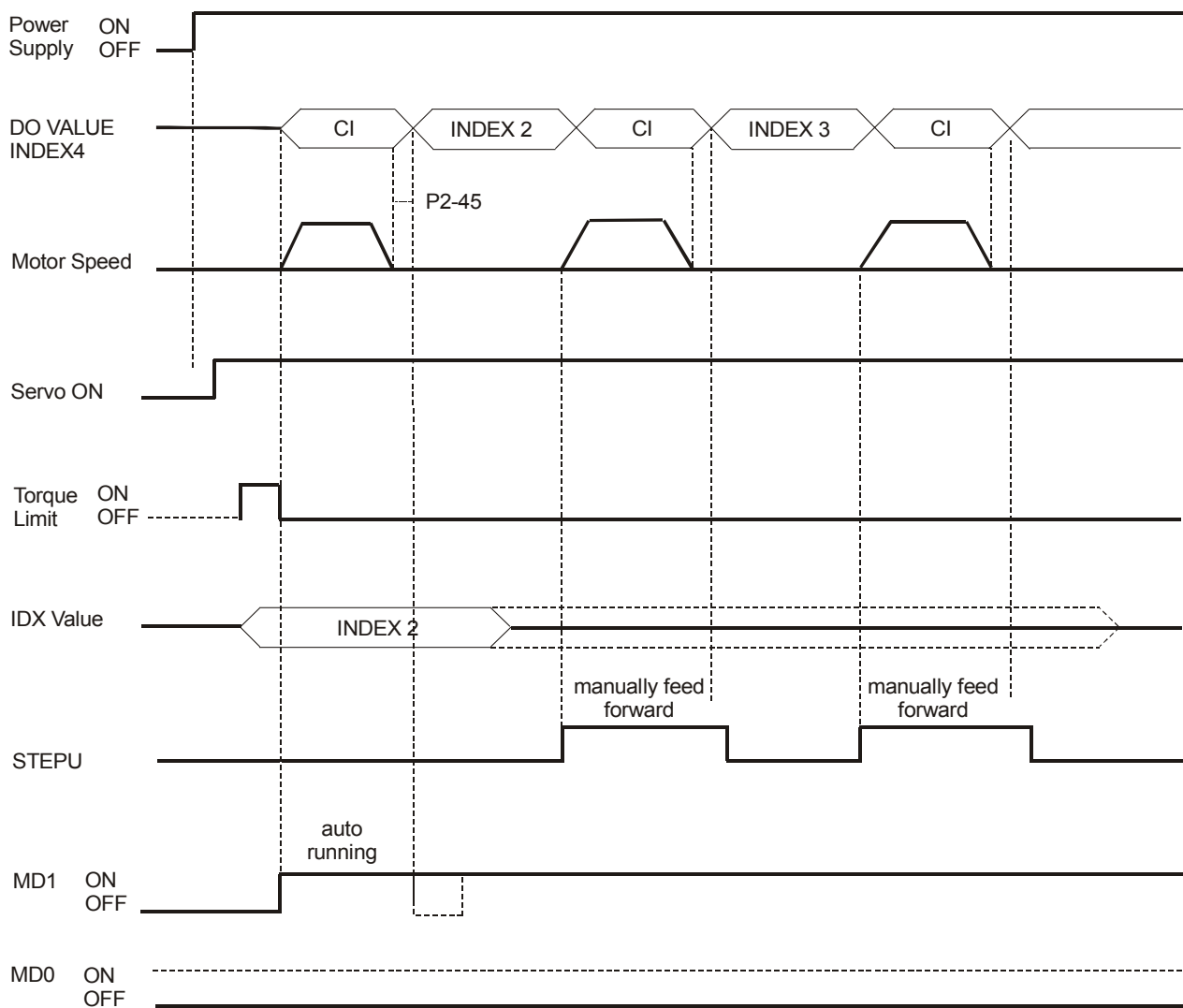

NOTE

- 1) When manually feed forward operation occurs, please set MD1 to be ON first (The feed step selection input should be kept unchanged to avoid returning to INDEX1 when manually feed forward operation occurs).
- 2) For manually single step operation speed, please refer to parameter P2-36.

Chapter 12 Application Examples | ASDA-A&A+ Series

(4) Manually Single Step Control Mode 2

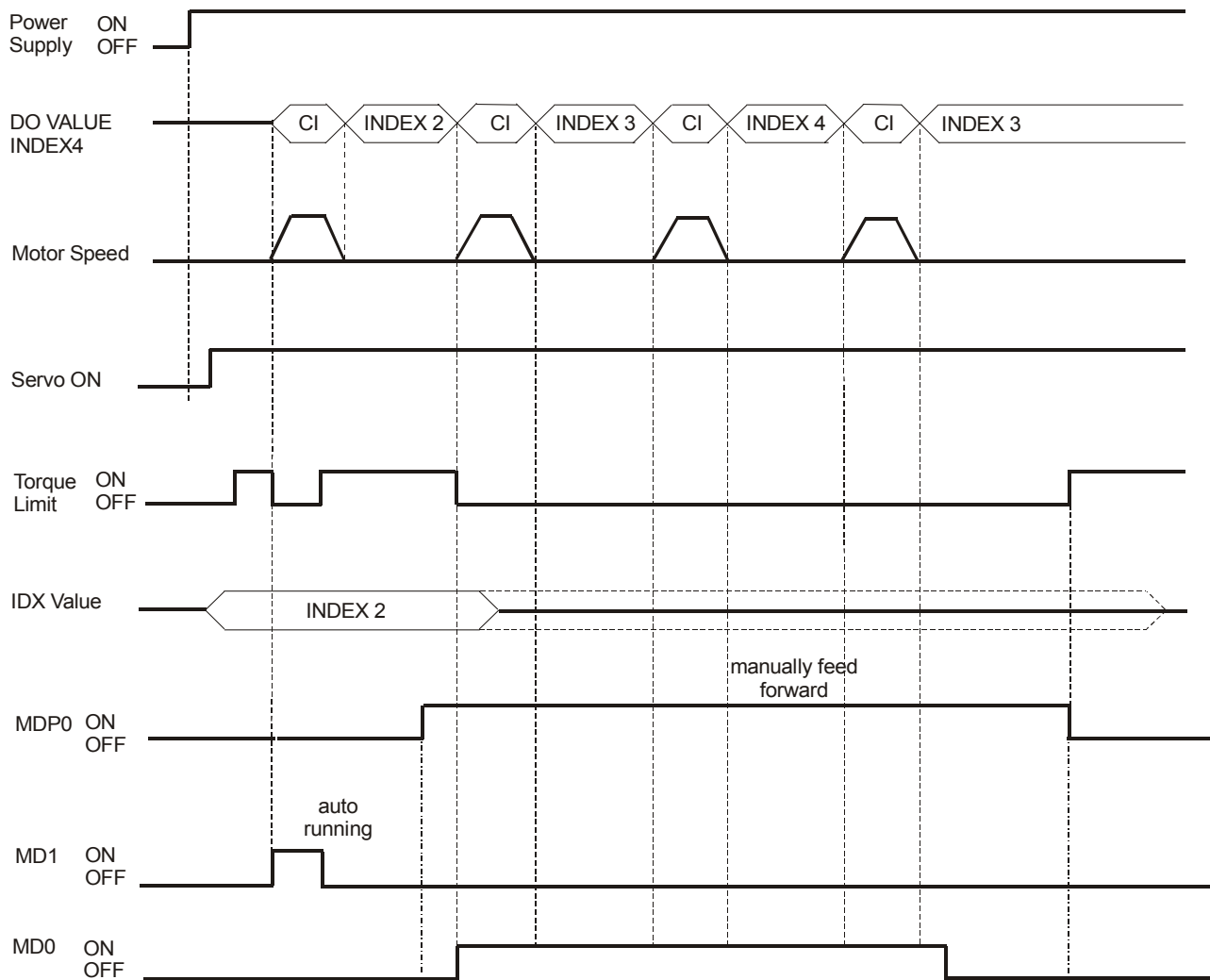

NOTE

- 1) After manually feed forward operation is completed, please set MD1 and MD0 to be OFF and then turn MDP1 from ON to OFF (ready to enter torque decrease status) to avoid any abnormal condition.
- 2) In manually feed forward mode (MDP1 is ON), if the rising-edge of MD0 is ON, then the servo motor will single step feed forward and if the rising-edge of MD1 is ON, then the servo motor will single step feed reverse.
- 3) For manually single step operation speed, please refer to parameter P2-37.

Chapter 12 Application Examples | ASDA-A&A+ Series

(5) Manually Continuous Step Control Mode

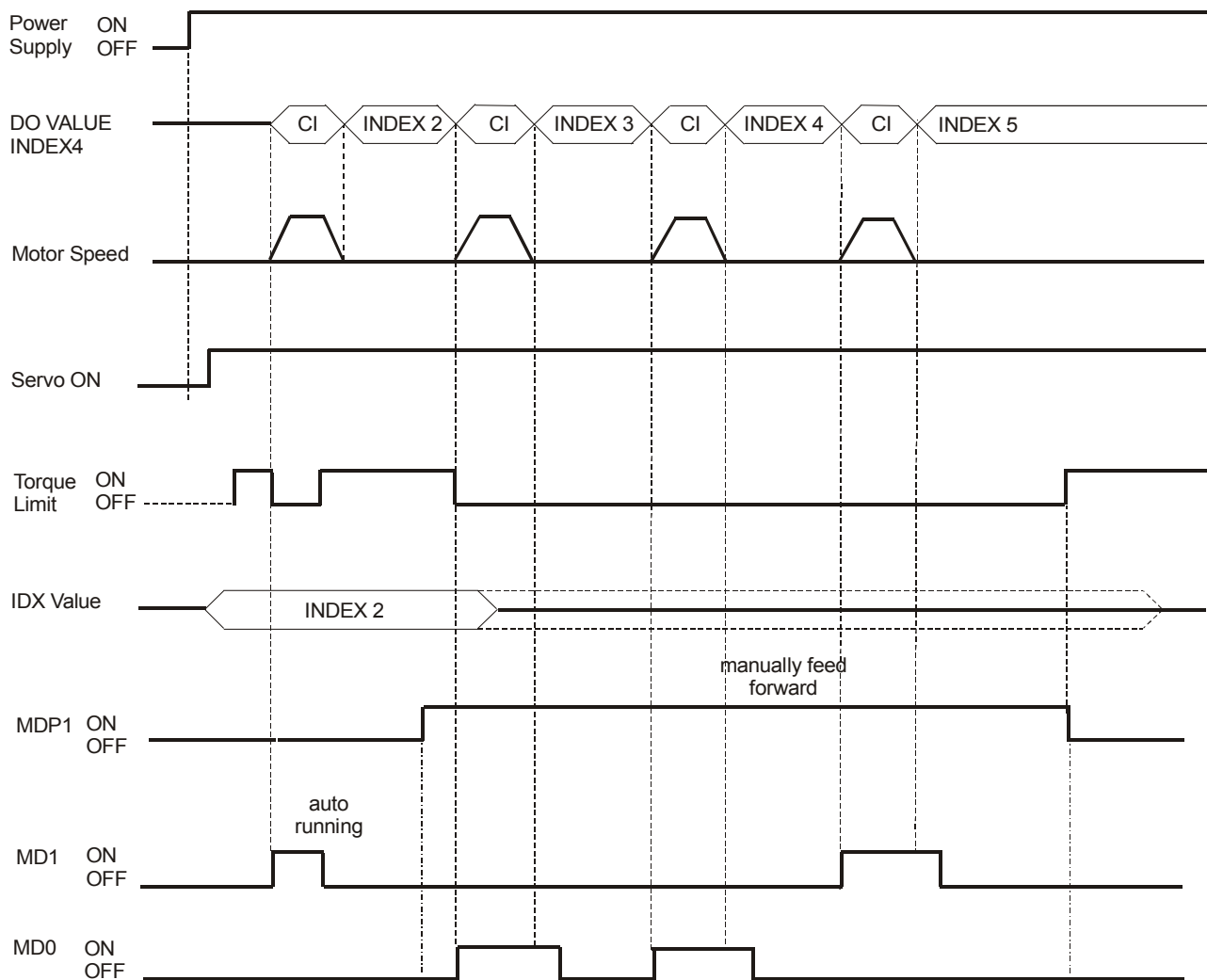

NOTE

- 1) After manually feed forward operation is completed, please set MD1 and MD0 to be OFF and then turn MDP0 from ON to OFF (ready to enter torque decrease status) to avoid any abnormal condition.
- 2) In manually feed forward mode (MDP0 is ON), if MD0 is ON, then the servo motor will continuous step feed forward and if MD1 is ON, then the servo motor will continuous step feed reverse.
- 3) For manually single step operation speed, please refer to parameter P2-37.

Chapter 12 Application Examples | ASDA-A&A+ Series**■ Communication Control Example Explanation**

Communication Address	Communication Content	Explanation
H306	H0FF	Set to software control
H407	H020	SERVO ON
H407	H060	HOMING
H407	H070	HOME SENSOR ON
H407	H060	HOME SENSOR OFF
H407	H020	Torque decrease
H407	H0A3	Index 3
H407	H023 (H020)	Torque decrease
H407	H0A5	Index 5
H407	H025 (H020)	Torque decrease
H407	H0An	Index n
H407	H02n (H020)	Torque decrease

Chapter 12 Application Examples | ASDA-A&A+ Series

12.7 Internal Auto Running Mode

■ Relevant Parameters Description

Parameter	Communication Address	Parameter Description
P1-01	0101H	Control Mode and Output Direction 001: Forward torque in Pr mode 101: Reverse torque in Pr mode
P1-33	0121H	Position Control Mode (Pr) 5: Continuous auto-running position command (Absolute) 6: Continuous auto position command (Incremental)
P1-34	0122H	Acceleration Time 1st to 3rd step Acceleration time (When parameter P1-36 is set to 0, accel / decel function is disabled, i.e. P1-34, P1-35 is disabled)
P1-35	0123H	Deceleration Time 1st to 3rd step Deceleration time (When parameter P1-36 is set to 0, accel / decel function is disabled, i.e. P1-34, P1-35 is disabled)
P1-36	0124H	Accel /Decel S-curve When parameter P1-36 is set to 0, accel / decel function is disabled, i.e. P1-34, P1-35 is disabled.
P1-44	012CH	Electronic Gear Ratio (1st Numerator) (N1) If the electronic gear deceleration ratio is 1/75, set numerator to 75
P1-45	012DH	Electronic Gear Ratio (Denominator)
P1-47	012FH	Homing Mode 202: When (MD1, MD0)=(OFF, ON), Forward Homing 203: When (MD1, MD0)=(OFF, ON), Reverse Homing
P1-50	0132H	Homing Offset Rotation Number
P1-51	0133H	Homing Offset Pulse Number Total homing offset pulse number =P1-50 x 10000 + P1-51
P2-44	022CH	Digital Output Mode Setting 0: General output mode 1: Combination output mode
P2-45	022DH	Combination Output Signal Delay Time [UNIT: 4msec] Output signal will hold delay time when position command is completed.
P2-51	0233H	Internal Servo ON setting

Chapter 12 Application Examples | ASDA-A&A+ Series

When the setting value of the time listed below is set to zero(0), the relative position will be ignored.

Positioning Point	Position Command Register	Moving Speed Register	Dwell Time Register
INDEX1	(P1-15, P1-16)	P2-36 (V1)	P2-52 (T1)
INDEX2	(P1-17, P1-18)	P2-37 (V2)	P2-53 (T2)
INDEX3	(P1-19, P1-20)	P2-38 (V3)	P2-54 (T3)
INDEX4	(P1-21, P1-22)	P2-39 (V4)	P2-55 (T4)
INDEX5	(P1-23, P1-24)	P2-40 (V5)	P2-56 (T5)
INDEX6	(P1-25, P1-26)	P2-41 (V6)	P2-57 (T6)
INDEX7	(P1-27, P1-28)	P2-42 (V7)	P2-58 (T7)
INDEX8	(P1-29, P1-30)	P2-43 (V8)	P2-59 (T8)

■ Digital I/O Signal Setting

DI Signal	Parameter Setting	Explanation
DI1 (SON)	P2-10 = 101	Servo ON
DI2 (AUTOR)	P2-11 = 142	Auto run input
DI3 (STEPD)	P2-12 = 140	Step down input
(STEPU)	P2-12 = 139	Step up input
(STEPB)	P2-12 = 141	Step back input.
DI4 (SHOM)	P2-13 = 127	Move to "Home"
DI5 (ORGP)	P2-14 = 124	Reference "Home" sensor
DI6 (CWL)	P2-15 = 22 (contact "b")	Reverse Inhibit limit
DI7 (CCWL)	P2-16 = 23 (contact "b")	Forward Inhibit limit
DI8 (EMGS)	P2-17 = 21 (contact "b")	Emergency stop

DO Signal	Parameter Setting	Explanation
DO1	P2-18 = 101	Please refer to "Definition of DO Signals" in the following section.
DO2	P2-19 = 103	
DO3	P2-20 = 109	
DO4	P2-21 = 105	
DO5	P2-22 = 107	

Chapter 12 Application Examples | ASDA-A&A+ Series

■ Definitions of DO Signals (ON:1, OFF:0)

Item	DO5	DO4	DO3	DO2	DO1	Function
1	0	0	0	0	0	ALARM
2	0	0	0	0	1	SERVO READY
3	0	0	0	1	0	HOMEING (under operation)
4	0	0	0	1	1	HOME Completed
5	0	0	1	0	0	CHANGE INDEX (under operation) (CHANGE INDEX hereinafter called "CI")
6	0	0	1	0	1	INDEX 1 (In position)
7	0	0	1	1	0	INDEX 2 (In position)
8	0	0	1	1	1	INDEX 3 (In position)
9	0	1	0	0	0	INDEX 4 (In position)
10	0	1	0	0	1	INDEX 5 (In position)
11	0	1	0	1	0	INDEX 6 (In position)
12	0	1	0	1	1	INDEX 7 (In position)
13	0	1	1	0	0	INDEX 8 (In position)

■ Timing charts of DI/DO Signals Operation

(1) Homing Mode

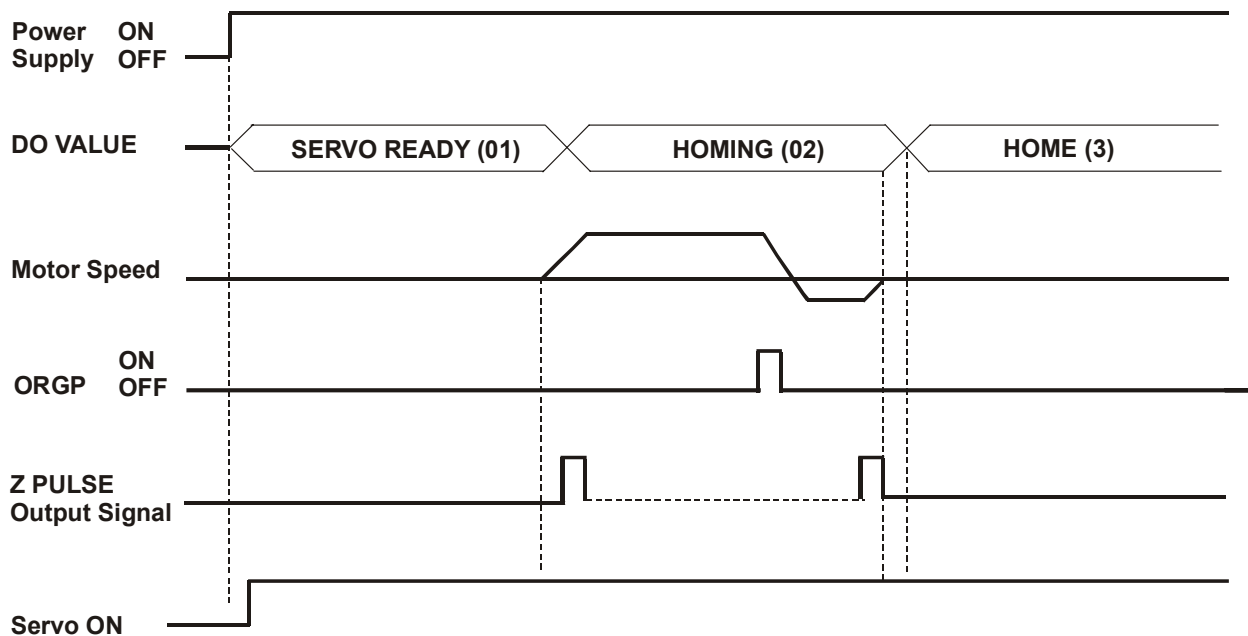

Chapter 12 Application Examples | ASDA-A&A+ Series

(2) Auto Running Mode

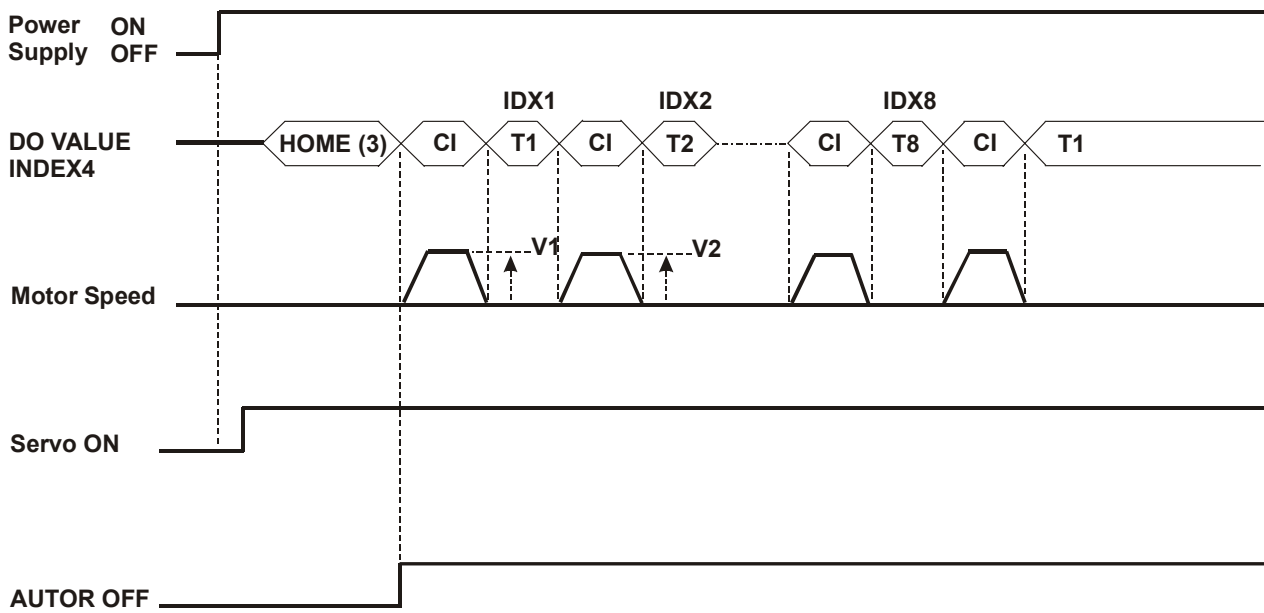

(3) Manual Control Mode 1

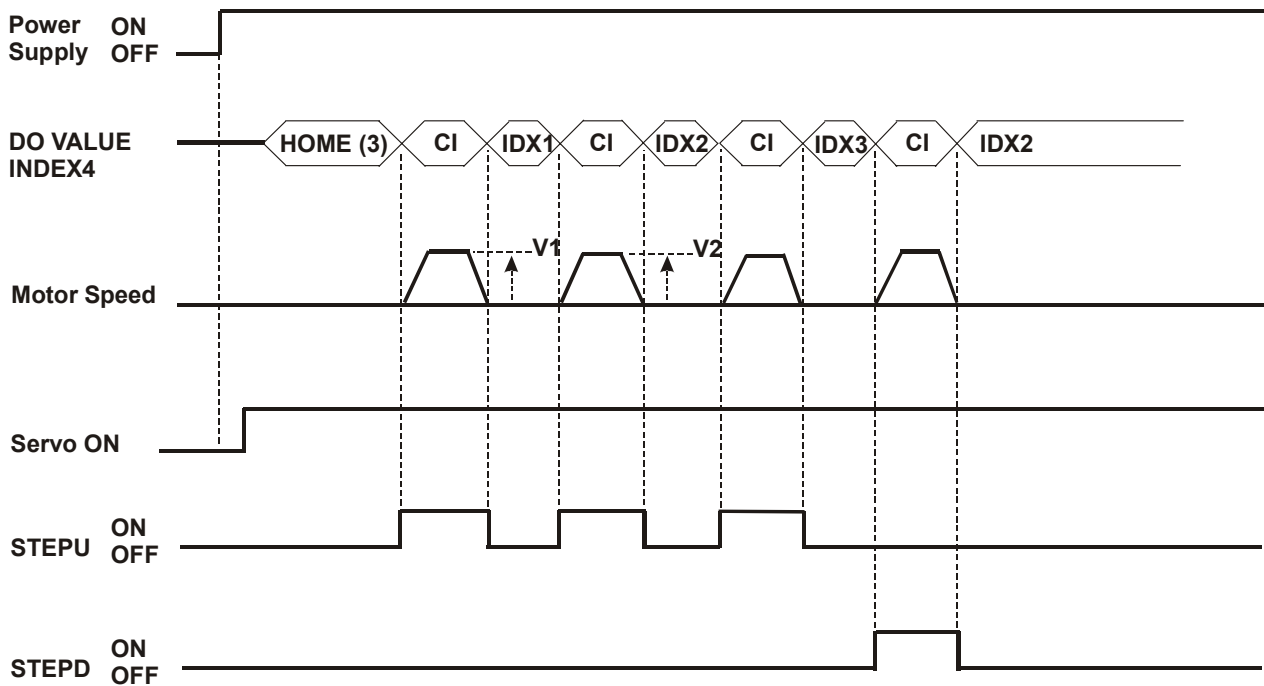

Chapter 12 Application Examples | ASDA-A&A+ Series

(4) Manual Control Mode 2

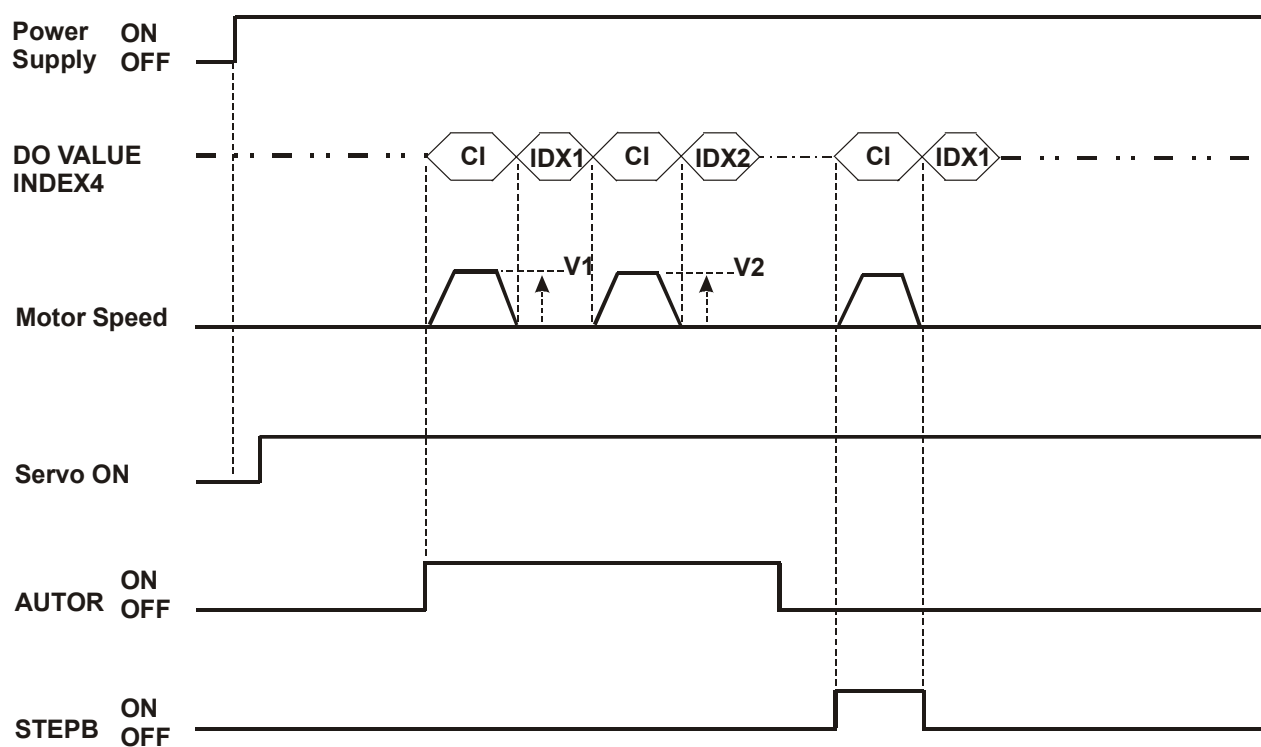

Chapter 12 Application Examples | ASDA-A&A+ Series

12.8 Homing Function

■ Relevant Parameters Description

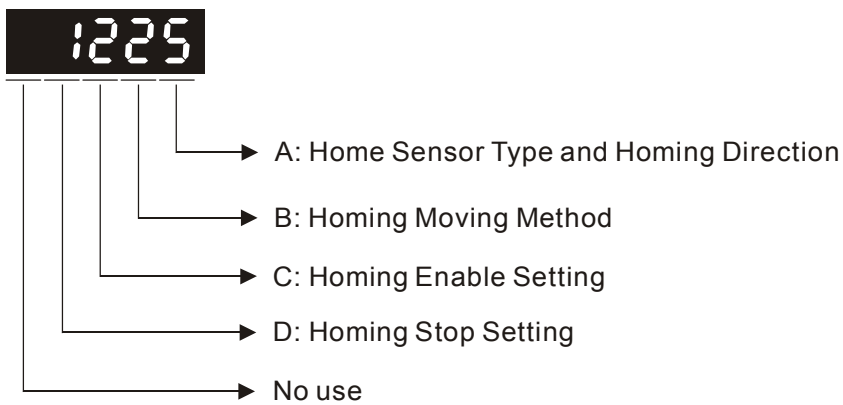
Parameter	Communication Address	Parameter Description
P1-47	012FH	Homing Mode 
P1-48	0130H	1st Speed Setting of High Speed Homing
P1-49	0131H	2nd Speed Setting of Low Speed Homing
P1-50	0132H	Homing Offset Rotation Number
P1-51	0133H	Homing Offset Pulse Number

■ Relevant Parameters Description, cont.

Parameter	Communication Address	Parameter Description
P1-34	0122H	Acceleration Time
P1-35	0123H	Deceleration Time
P1-36	0124H	Accel /Decel S-curve

■ Explanation of Homing Mode

A: Home Sensor Type and Homing Direction

Left or right limit switch can be used as a reference "Home" for homing function. It also can use extra sensor, such as proximity switch or photo switch as reference "Home". When the servo motor runs within one revolution only, users also can set Z-phase pulse as a reference "Home".

A=0: Forward homing and CCWL limit input point is regarded as a rough reference "Home". When home is in position, CCWL will turn into limit input function. If trigger CCWL afterward, the limit alarm will occur.

When use limit input point as a rough reference "Home", we recommend users to set B=0, i.e. return to find Z-phase pulse during homing and regard Z-phase pulse as a precise mechanical "Home".

A=1: Reverse homing and CWL limit input point is regarded as a rough reference "Home". When home is in position, CWL will turn into limit input function. If trigger CWL afterward, the limit alarm will occur. When use limit input point as a rough reference "Home", we recommend users to set B=0, i.e. return to find Z-phase pulse during homing and regard Z-phase pulse as a precise mechanical "Home".

Chapter 12 Application Examples | ASDA-A&A+ Series

A=2: Forward homing and ORGP (Reference “Home” sensor) is regarded as a reference “Home”. At this time, users can set B=0, i.e. return to find Z-phase pulse during homing and regard Z-phase pulse as a precise mechanical “Home” or set B=1, i.e. do not return and go forward to find Z-phase pulse and regard Z-phase pulse as a precise mechanical “Home”. If users do not use Z-phase pulse as mechanical “Home”, users can set the rising-edge of ORGP as the mechanical “Home” (B=2).

A=3: Reverse homing and ORGP (Reference “Home” sensor) is regarded as a reference “Home”. At this time, users can set B=0, i.e. return to find Z-phase pulse during homing and regard Z-phase pulse as a precise mechanical “Home” or set B=1, i.e. do not return and go forward to find Z-phase pulse and regard Z-phase pulse as a precise mechanical “Home”. If users do not use Z-phase pulse as mechanical “Home”, users can set the rising-edge of ORGP as the mechanical “Home” (B=2).

A=4: Forward-finding Z-phase pulse “Home”. This function is usually used when the servo motor runs within one revolution. The servo motor can not be connected to any external sensor switch at this time.

A=5: Reverse-finding Z-phase pulse “Home”. This function is usually used when the servo motor runs within one revolution. The servo motor can not be connected to any external sensor switch at this time.

B: Homing Moving Method

B=0: After find reference “Home” (after homing completed), the servo motor returns in 2nd step speed to find the nearest Z-phase pulse as the mechanical “Home”.

B=1: After find reference “Home” (after homing completed), the servo motor does not return and continue to go forward in 2nd step speed to find the nearest Z-phase pulse as the mechanical “Home”.

B=2: When A=2 and A=3, find the rising-edge of sensor ORGP as the mechanical “Home” and stop according to deceleration time. When A=4 and A=5, stop according to deceleration time after find Z-phase pulse.

C: Homing Enable Setting

There are two settings for enabling homing function. One is automatically enable homing function and the other is to enable homing function by input contact (SHOM).

C=0: Disable homing function. When C is set to 0, it indicates that homing function is disabled no matter what other parameter values are.

C=1: Enable homing function automatically after power in connected to the servo drive. This function is valid only when power on and servo on. It is used on condition that it doesn't need to repeat the execution of homing function when the servo drive is operating. Use this function can save an input contact which is used for executing homing function.

C=2: Enable homing function by SHOM input contact. To use this function, set any one register of parameter P2-10 ~ P2-17 (Digital Input Terminal 1 ~ 8) to SHOM. The setting value of parameter P2-10 ~ P2-17 should be 127(contact “a”) or 27(contact “b”). Then, user can enable the homing function by triggering SHOM input contact at any time when the servo drive is operating.

Chapter 12 Application Examples | ASDA-A&A+ Series

D: Homing Stop Setting

D=0: After detecting "Home", the motor will decelerate and return to "Home". After get the home sensor signal in 2nd step speed operation, the motor will decelerate and stop. After the servo motor stops, the then move to the position of mechanical "Home".

D=1: After detecting "Home", the motor will decelerate and stop in the forward direction.

After get the home sensor signal in 2nd step speed operation, the motor will decelerate and stop. After the servo motor stops, the over distance will not be corrected. The position of mechanical "Home" will not change by the difference of the over distance.

■ Recommended Homing Modes

According to various use requirements and corresponds to difference setting values of C and D, the recommended setting values of A and B are shown as below:

B \ A	0	1	2	3	4	5
0	Y	Y	Y	Y	N	N
1	N	N	Y	Y	N	N
2	N	N	Y	Y	Y	Y

(Y=Yes, N=No)

■ Homing Timing Charts

Timing Charts of Enable Homing Mode

1. Automatically enable homing function when power on (C=1)

After homing is completed, if any one of output function definition (DO) of parameter P2-18 ~ P2-22 is HOME (setting value is 09 or 109), the corresponding output terminal will generate output signal immediately (Active). If servo on input signal is canceled or any alarm occurs in the process of homing, the homing function will terminate and do not output homing completed signal.

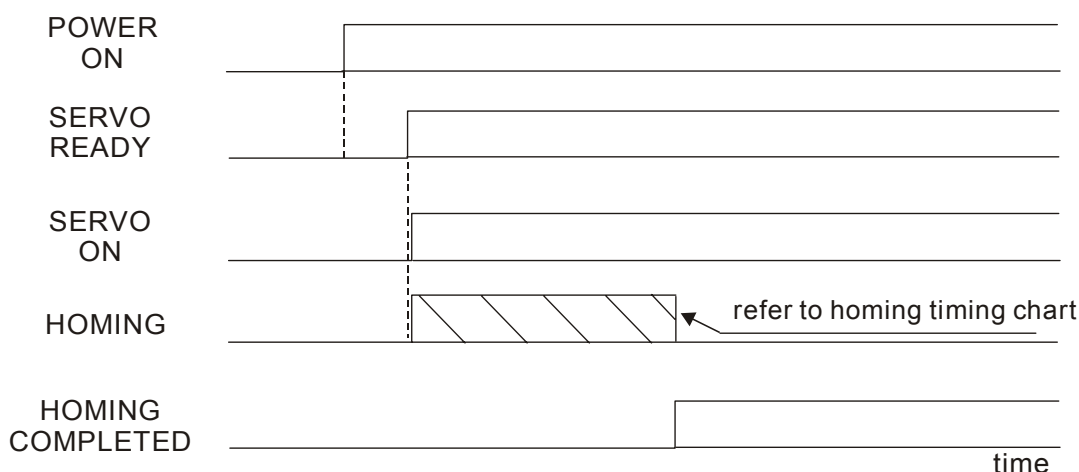

Chapter 12 Application Examples | ASDA-A&A+ Series

2. Enable homing function by input contact (SHOM) (C=2)

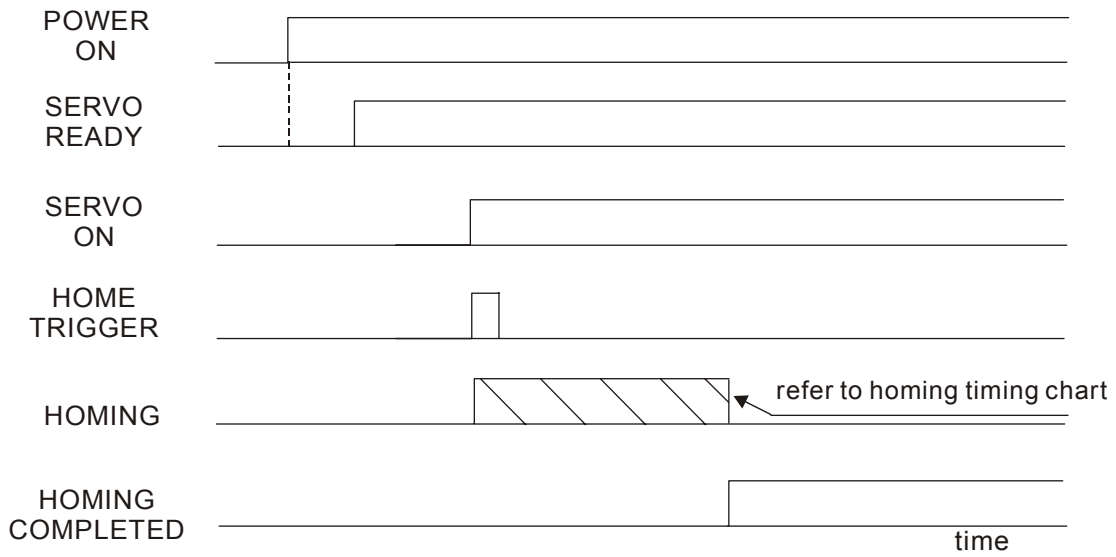

Homing Timing Charts

1. B/A = 0/0 or B/A = 0/2

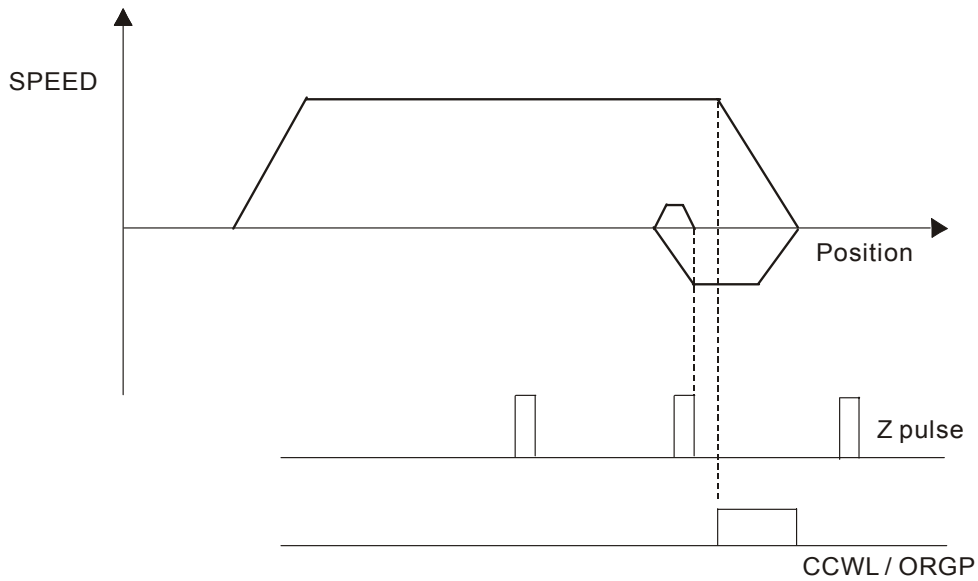

Chapter 12 Application Examples | ASDA-A&A+ Series

2. $B/A = 0/1$ or $B/A = 0/3$

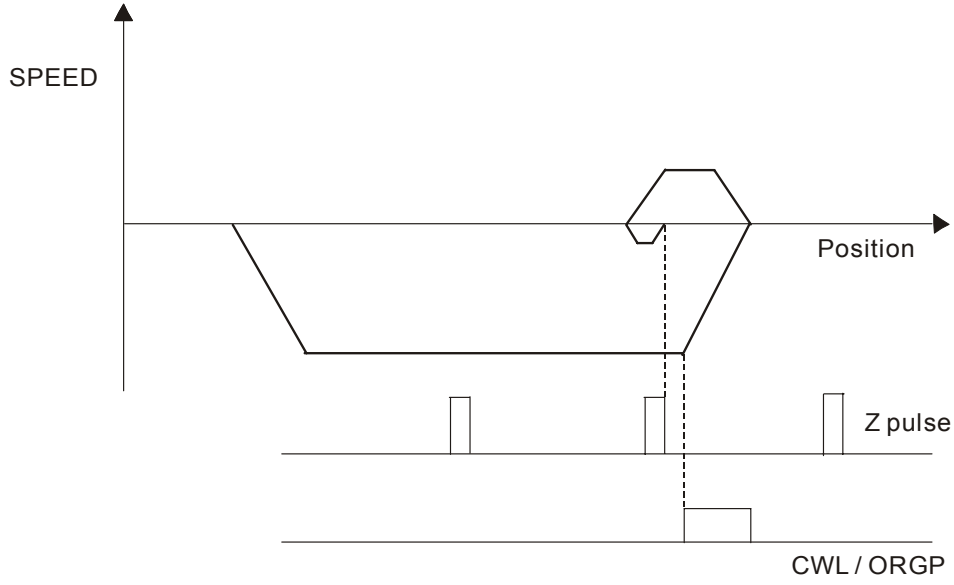

3. $B/A = 1/2$

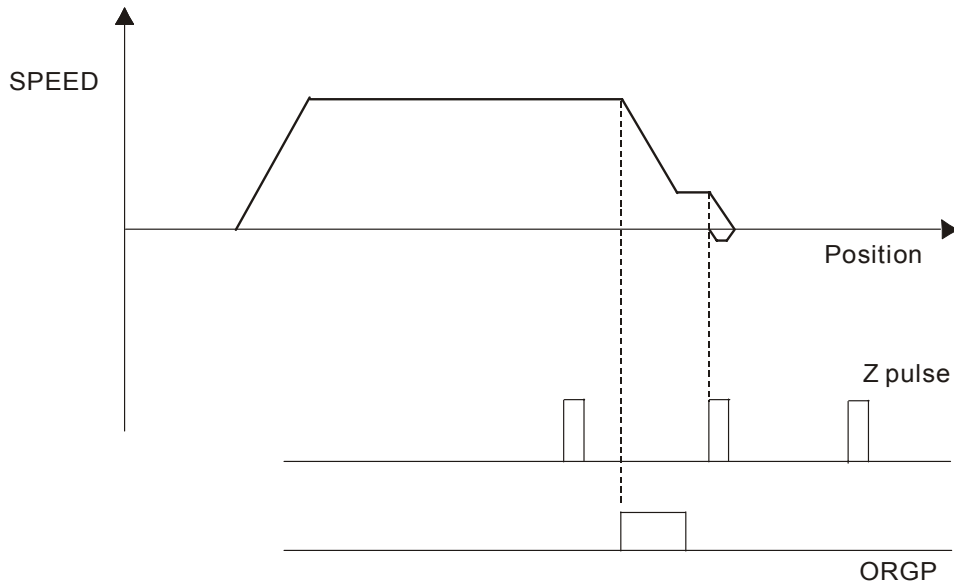

4. $B/A = 1/3$

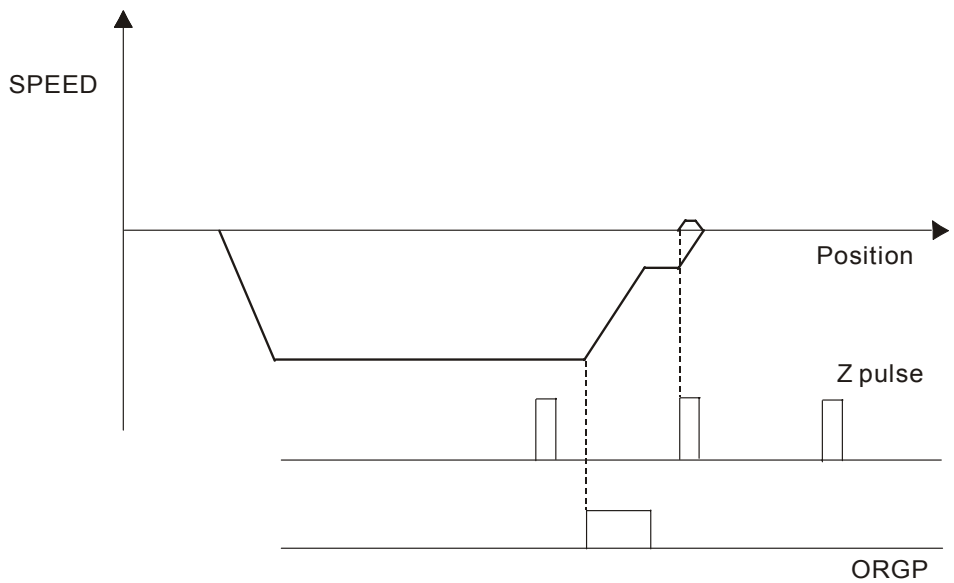

Chapter 12 Application Examples | ASDA-A&A+ Series

5. $B/A = 2/2$

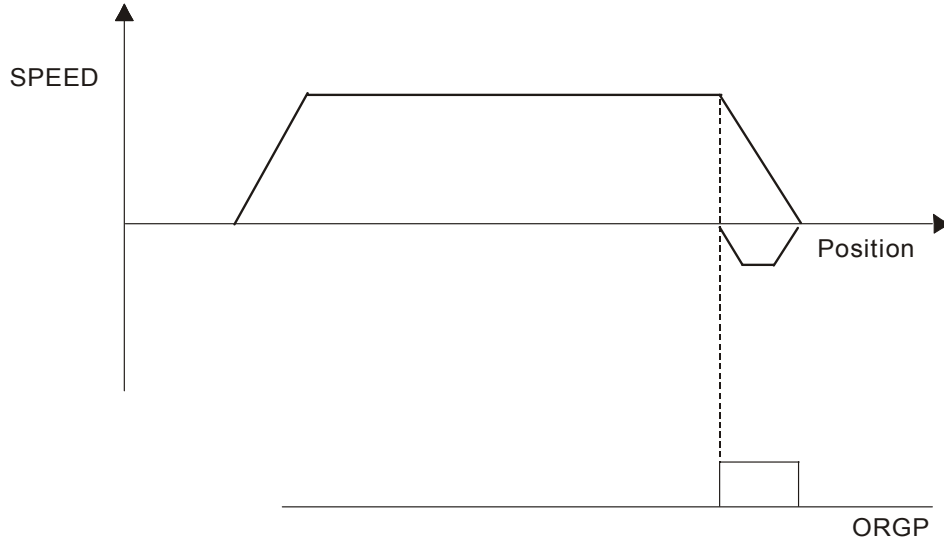

6. $B/A = 2/3$

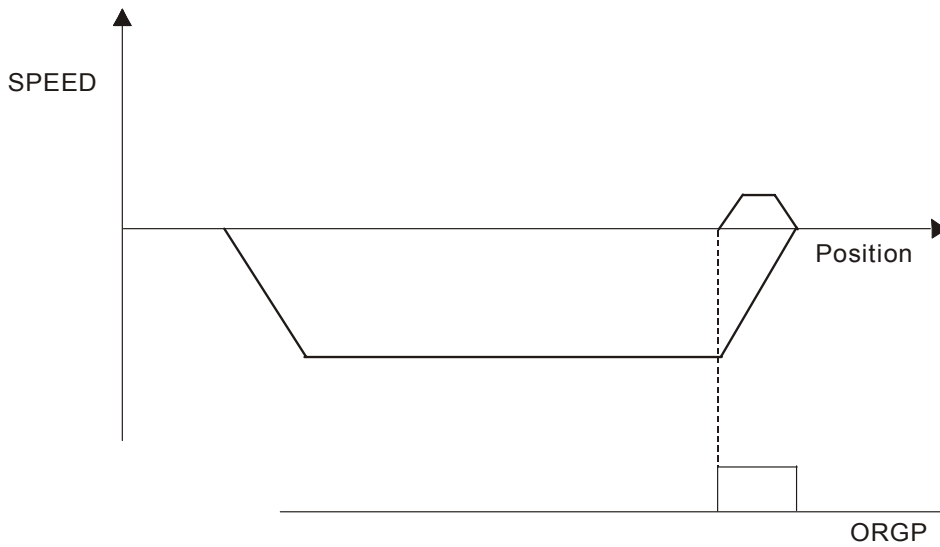

7. $B/A = 2/4$

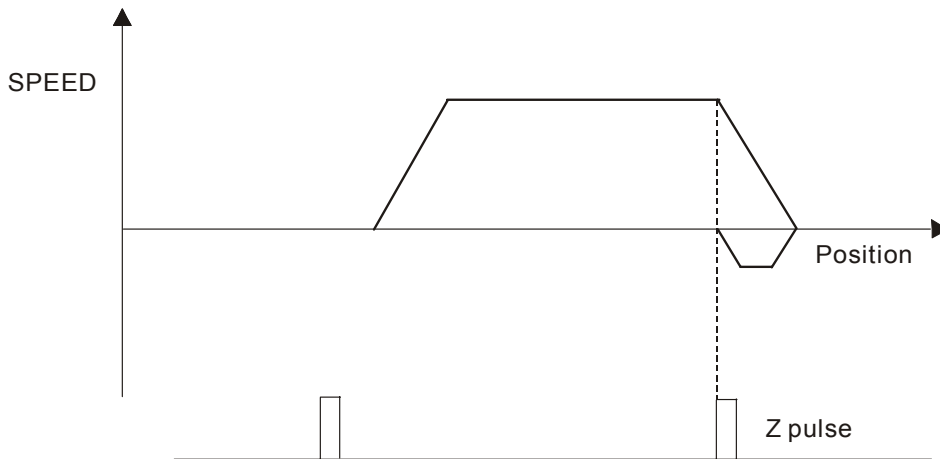

Chapter 12 Application Examples | ASDA-A&A+ Series

8. $B/A = 2/5$

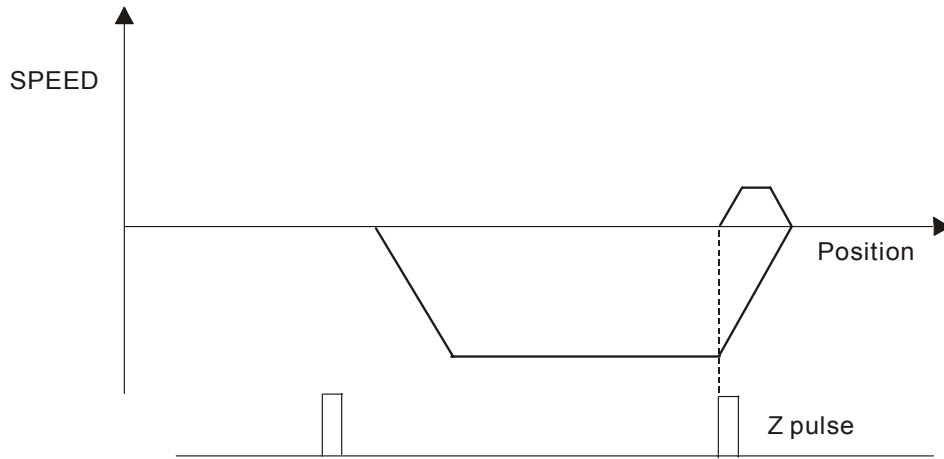

Chapter 12 Application Examples | ASDA-A&A+ Series

12.9 External Controller Connection Examples

■ Connecting to Delta DVP-EH PLC

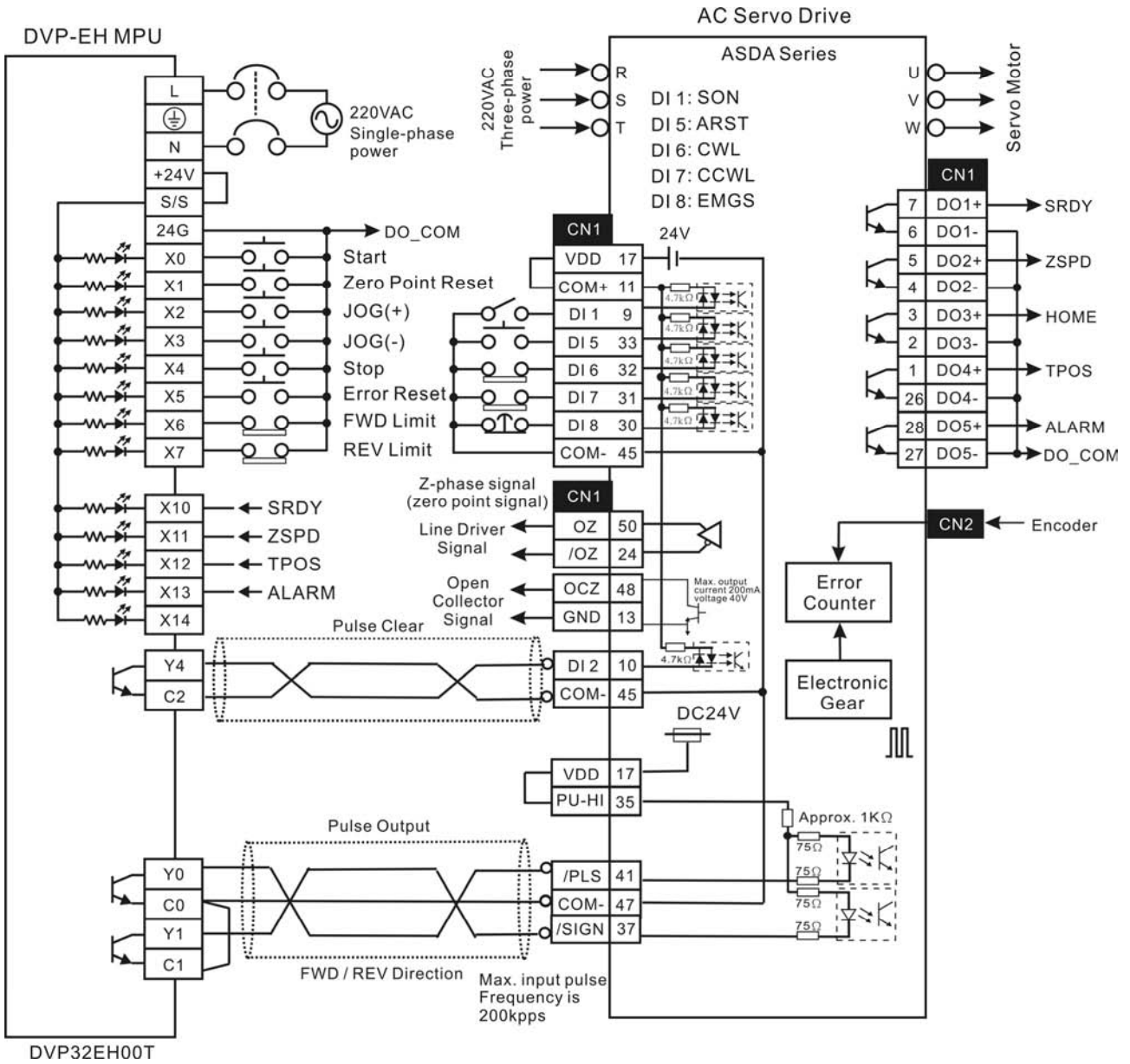

Chapter 12 Application Examples | ASDA-A&A+ Series

■ Connecting to Delta DVP-01PU

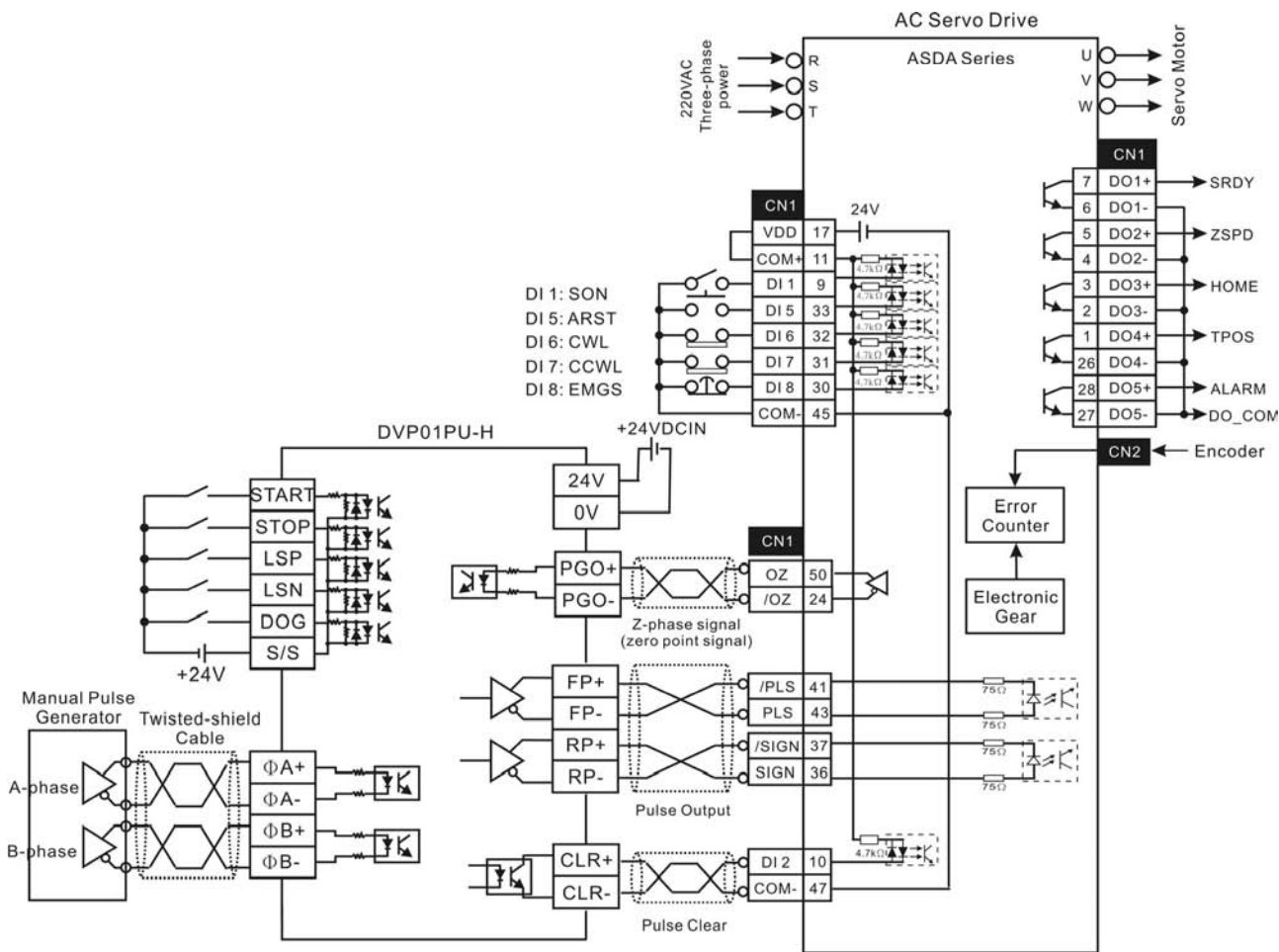

Chapter 12 Application Examples | ASDA-A&A+ Series

■ Connecting to Mitsubishi FX1PG

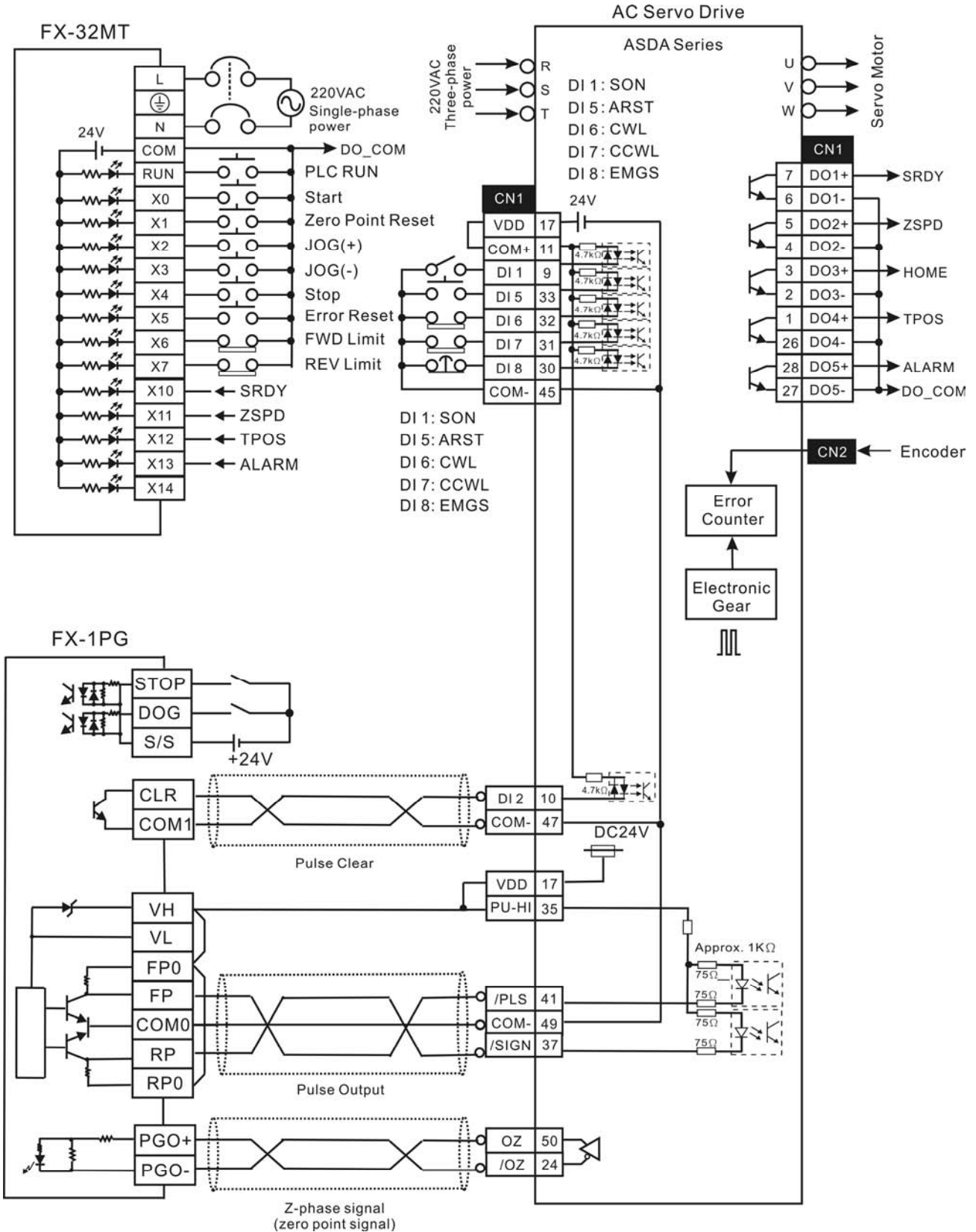

Chapter 12 Application Examples | ASDA-A&A+ Series

■ Connecting to Mitsubishi FX2N1PG

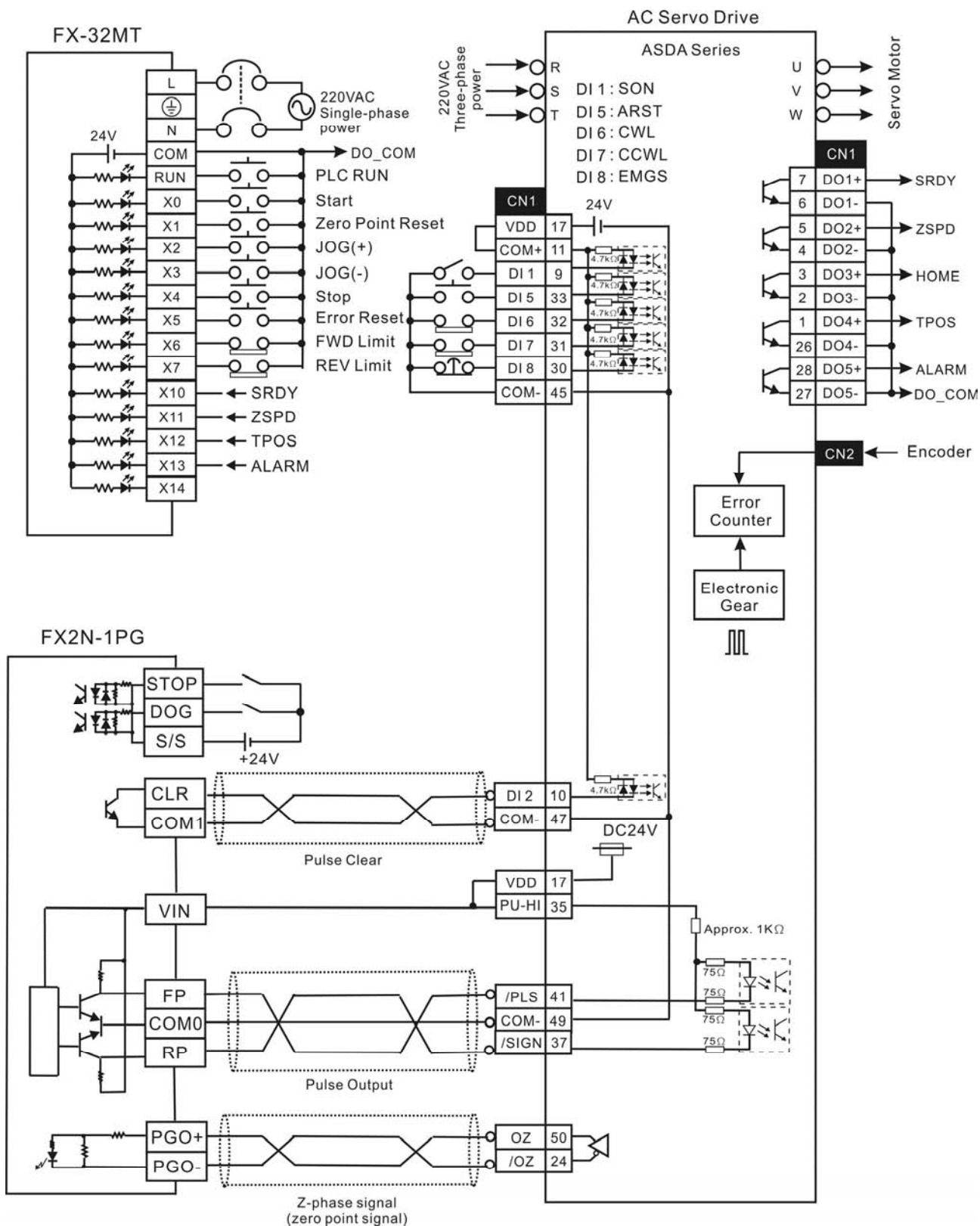

Chapter 12 Application Examples | ASDA-A&A+ Series

■ Connecting to Mitsubishi AD75

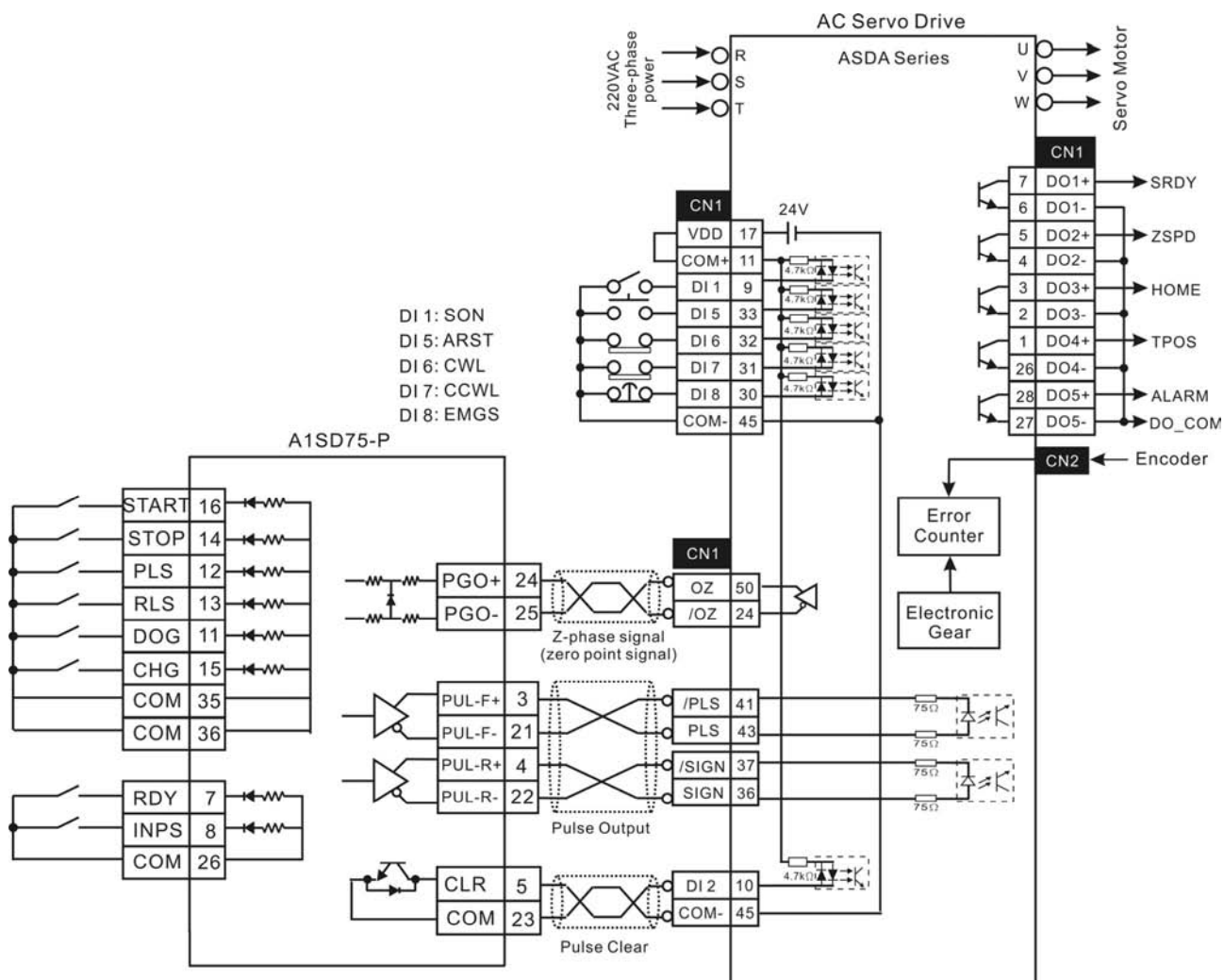

Chapter 12 Application Examples | ASDA-A&A+ Series

This page intentionally left blank.

Appendix A Accessories

■ Power Connectors

Delta Part Number: ASD-CAPW0000

Housing: AMP 350780-1

Terminal: AMP 350537-3

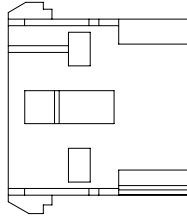

Delta Part Number: ASD-CAPW0100

Housing: AMP 350781-1

UVW Terminal: AMP 350537-3

Brake Terminal: AMP 350570-3

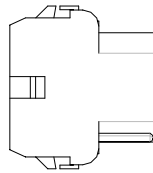

Delta Part Number: ASD-CAPW1000

CLAMP: MS3057-12A

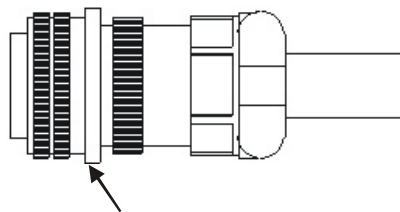

Straight Plug MS 3106-20-18S

Appendix A Accessories | ASDA-A&A+ Series

Delta Part Number: ASD-CAPW2000 (for models of 4.5kW and below)

CLAMP: MS3057-16A

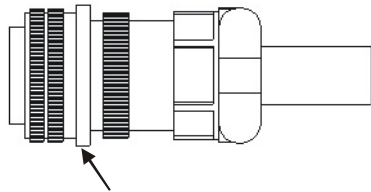

Straight Plug MS 3106-24-11S

Delta Part Number: ASD-CAPW4000 (for models of 5.5kW and above)

CLAMP: WPS3057-20A

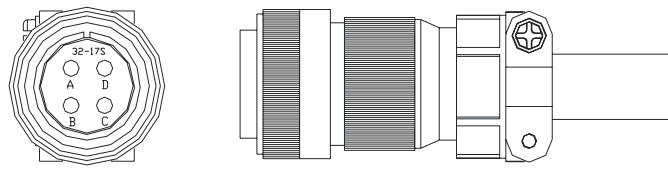

Straight Plug WPS3106A-32-17S

Motor Brake Connector: ASD-CNBR1000 (for models of 5.5kW and above)

CLAMP: WPS3106A 10SL-4S-R

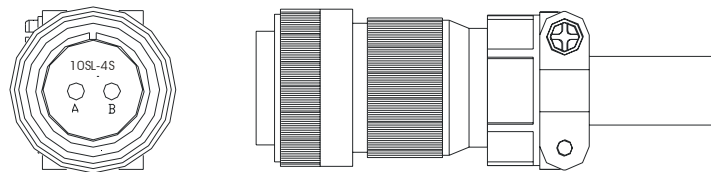

D

■ **Power Cables**

Delta Part Number: ASD-CAPW0003, ASD-CAPW0005

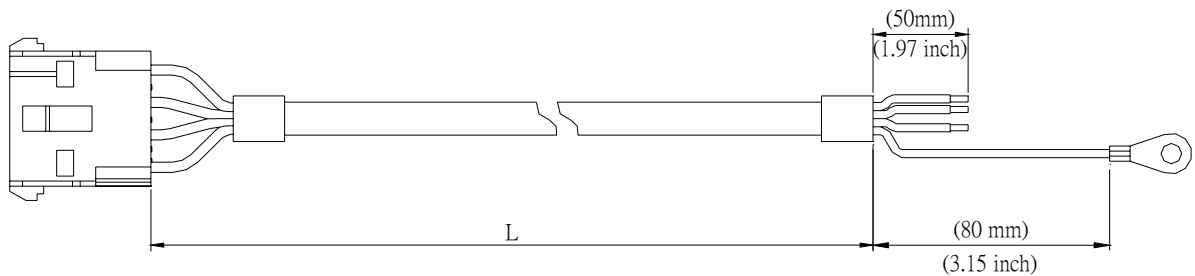

Title	Part No.	L	
		mm	inch
1	ASD-CAPW0003	3000 ± 10	118 ± 0.4
2	ASD-CAPW0005	5000 ± 10	197 ± 0.4

Appendix A Accessories | ASDA-A&A+ Series

Delta Part Number: ASD-CAPW0103, ASD-CAPW0105

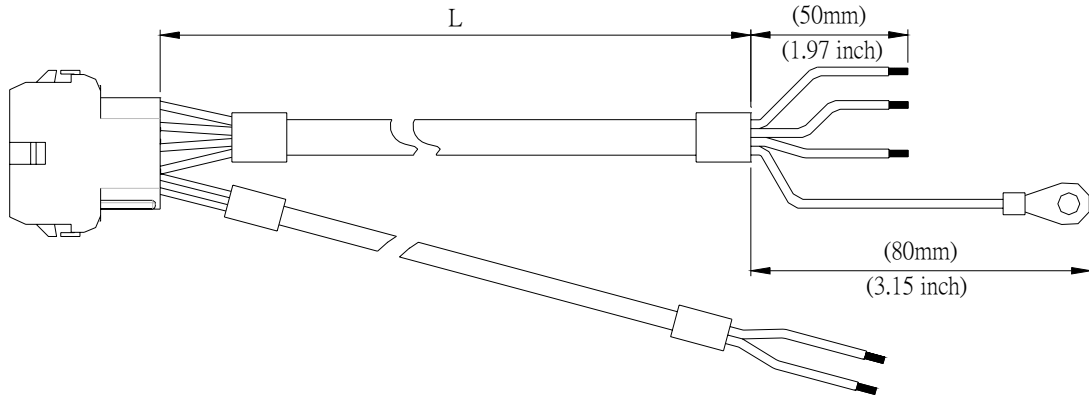

Title	Part No.	L	
		mm	inch
1	ASD-CAPW0003	3000 ± 10	118 ± 0.4
2	ASD-CAPW0005	5000 ± 10	197 ± 0.4

Delta Part Number: ASD-CAPW1003, ASD-CAPW1005

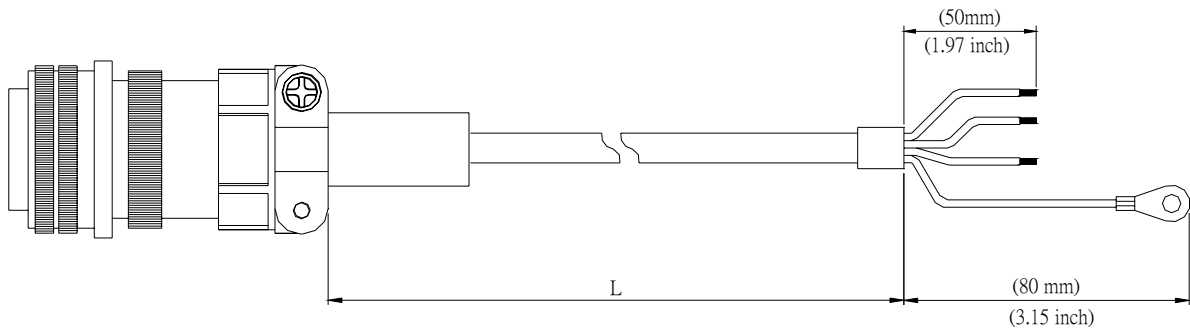

Title	Part No.	Straight	L	
			mm	inch
1	ASD-CAPW1003	MS 3106-20-18S	3000 ± 10	118 ± 0.4
2	ASD-CAPW1005	MS 3106-20-18S	5000 ± 10	197 ± 0.4

Appendix A Accessories | ASDA-A&A+ Series

Delta Part Number: ASD-CAPW1103, ASD-CAPW1105

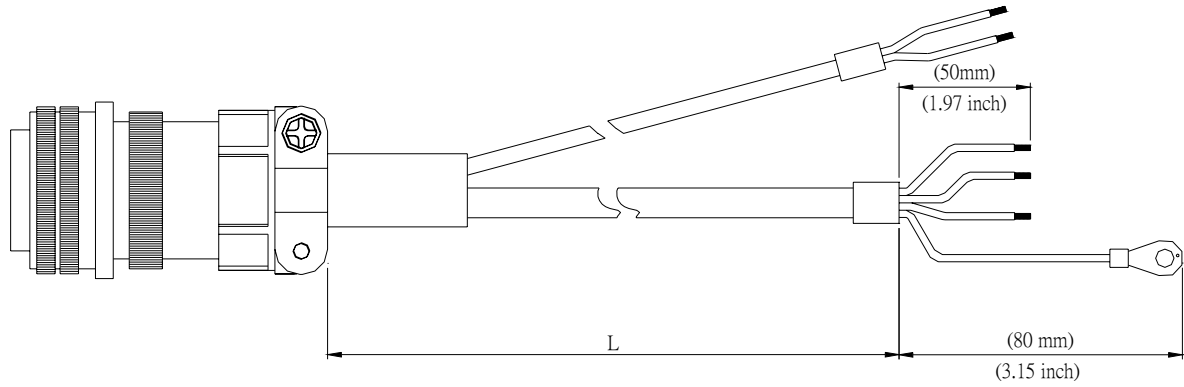

Title	Part No.	Straight	L	
			mm	inch
1	ASD-CAPW1103	MS 3106-20-18S	3000 ± 10	118 ± 0.4
2	ASD-CAPW1105	MS 3106-20-18S	5000 ± 10	197 ± 0.4

Delta Part Number: ASD-CAPW1203, ASD-CAPW1205

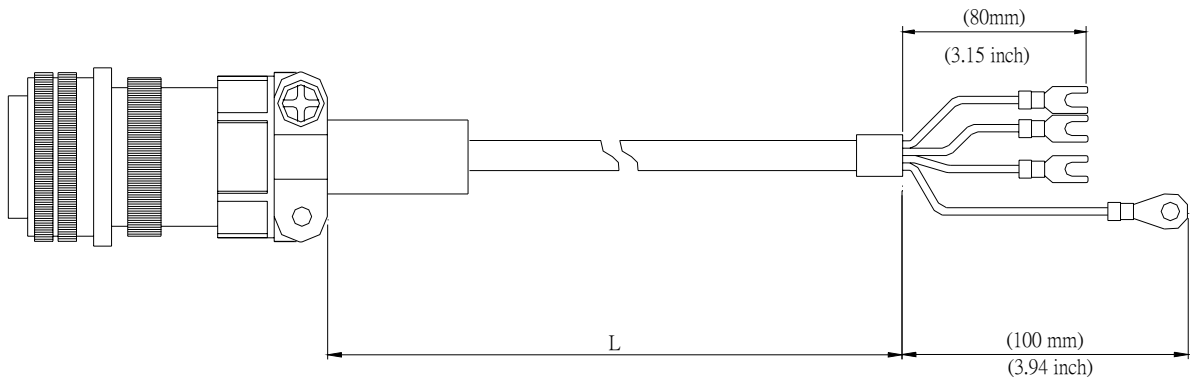

Title	Part No.	Straight	L	
			mm	inch
1	ASD-CAPW1203	MS 3106-20-18S	3000 ± 10	118 ± 0.4
2	ASD-CAPW1205	MS 3106-20-18S	5000 ± 10	197 ± 0.4

Appendix A Accessories | ASDA-A&A+ Series

Delta Part Number: ASD-CAPW1303, ASD-CAPW1305

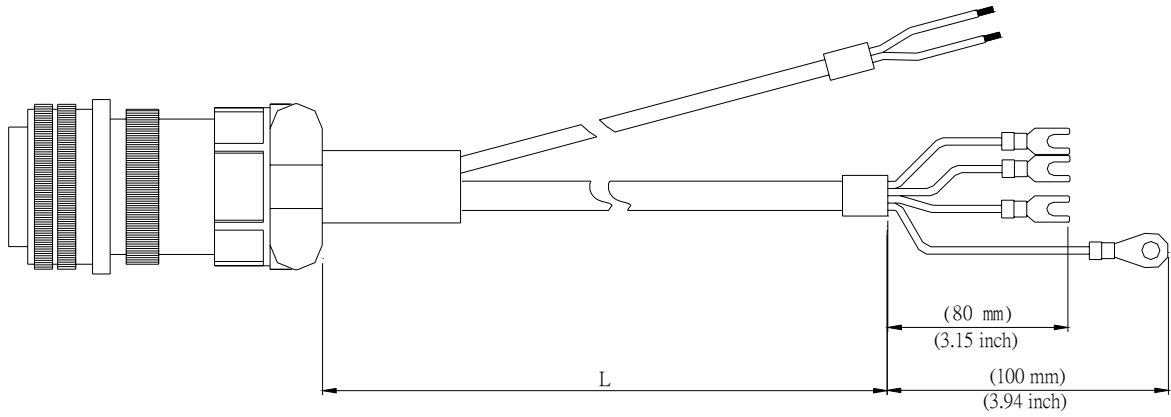

Title	Part No.	Straight	L	
			mm	inch
1	ASD-CAPW1303	MS 3106-20-18S	3000 ± 10	118 ± 0.4
2	ASD-CAPW1305	MS 3106-20-18S	5000 ± 10	197 ± 0.4

Delta Part Number: ASD-CAPW2203, ASD-CAPW2205 (for models of 3kW and below)

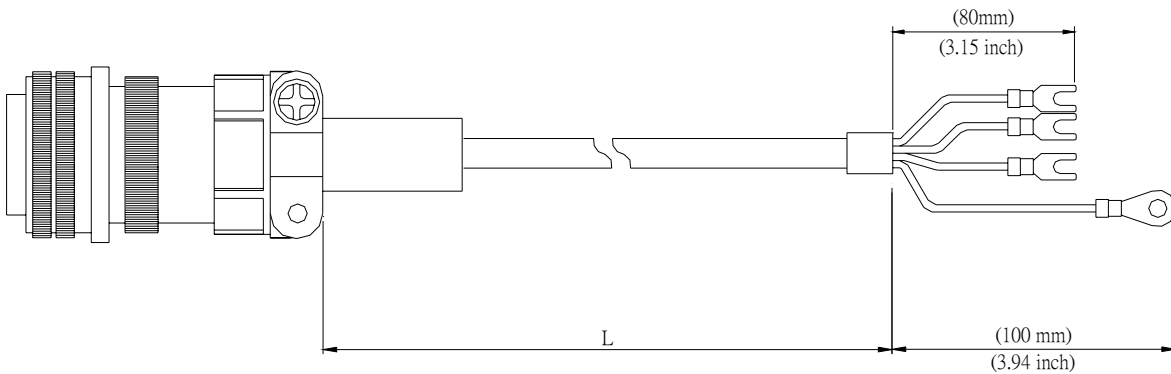

Title	Part No.	Straight	L	
			mm	inch
1	ASD-CAPW2203	MS 3106-24-11S	3000 ± 10	118 ± 0.4
2	ASD-CAPW2205	MS 3106-24-11S	5000 ± 10	197 ± 0.4

Appendix A Accessories | ASDA-A&A+ Series

**Delta Part Number: ASD-CAPW2303, ASD-CAPW2305 (cable for motors with brake)
(for models of 3kW and below)**

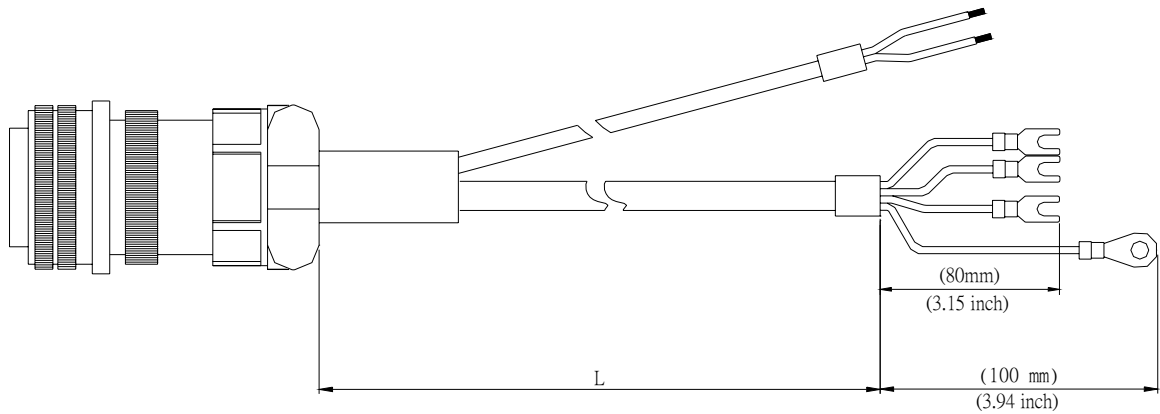

Title	Part No.	Straight	L	
			mm	inch
1	ASD-CAPW2303	MS 3106-24-11S	3000 ± 10	118 ± 0.4
2	ASD-CAPW2305	MS 3106-24-11S	5000 ± 10	197 ± 0.4

Power Cables: ASD-CAPW3203, ASD-CAPW3205 (for 4.5kW model)

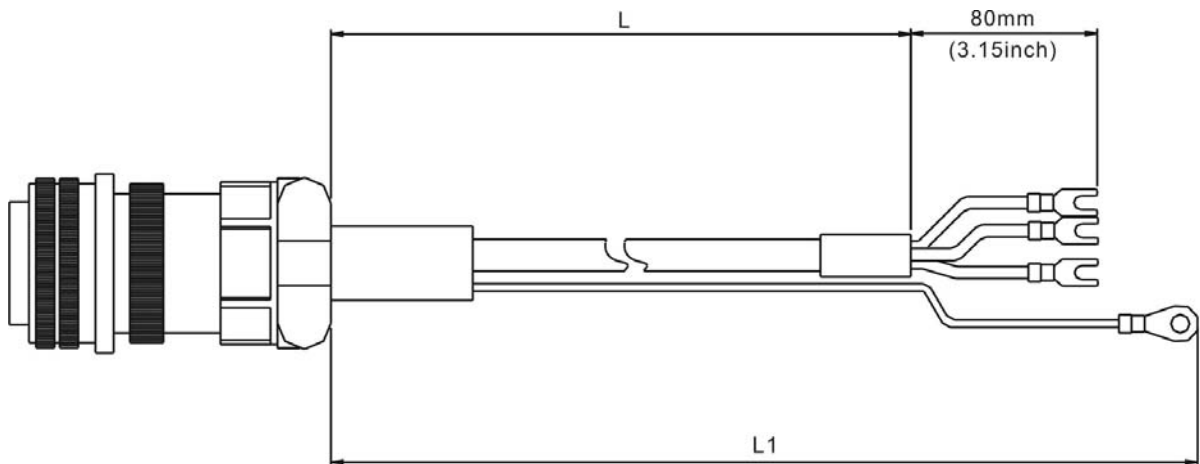

Item	Part No.	Straight	L		L1	
			mm	inch	mm	inch
1	ASD-CAPW3203	MS 3106-24-11S	3000 ± 10	118 ± 0.4	3100 ± 10	122 ± 0.4
2	ASD-CAPW3205	MS 3106-24-11S	5000 ± 10	197 ± 0.4	5100 ± 10	201 ± 0.4

Appendix A Accessories | ASDA-A&A+ Series

**Power Cables: ASD-CAPW3303, ASD-CAPW3305 (cable for motors with brake)
(for 4.5kW model)**

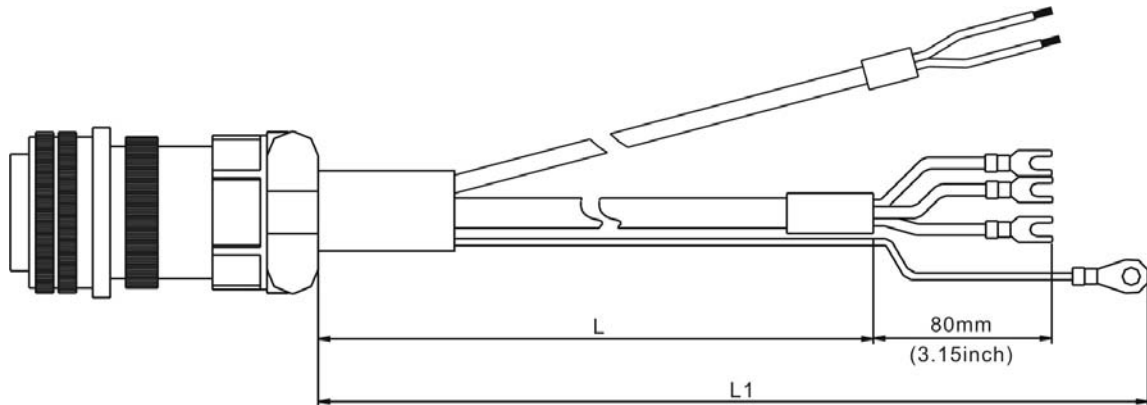

Item	Part No.	Straight	L		L1	
			mm	inch	mm	inch
1	ASD-CAPW3303	MS 3106-24-11S	3000 ± 10	118 ± 0.4	3100 ± 10	122 ± 0.4
2	ASD-CAPW3305	MS 3106-24-11S	5000 ± 10	197 ± 0.4	5100 ± 10	201 ± 0.4

■ **Encoder Connectors**

Delta Part Number: ASD-CAEN0000

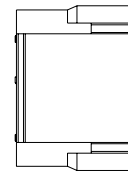
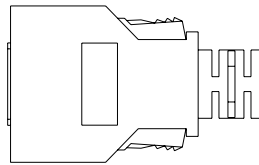

Vendor Name	Vendor P/N
3M TAIWAN LTD	10120-3000PE
3M TAIWAN LTD	10320-52A0-008

HOUSING: AMP (1-172211-0)
TERMINAL: AMP (170376-3)

Delta Part Number: ASD-CAEN1000

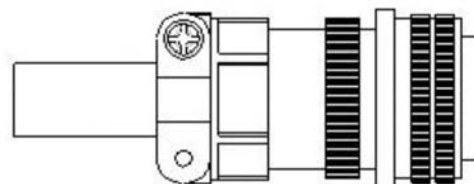
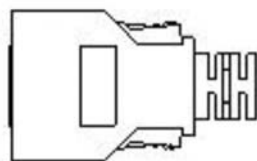

Straight plug MS 3106-20-29S

Appendix A Accessories | ASDA-A&A+ Series

■ **Encoder Cables**

Delta Part Number: ASD-CAEN0003, ASD-CAEN0005

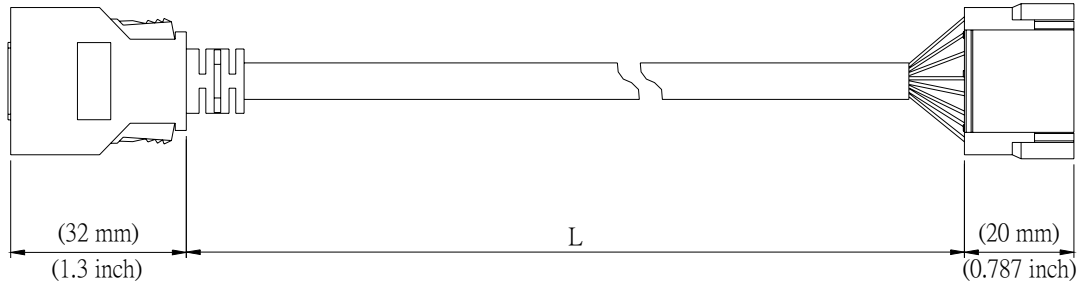

Title	Part No.	L	
		mm	inch
1	ASD-CAEN0003	3000 ± 10	118 ± 0.4
2	ASD-CAEN0005	5000 ± 10	197 ± 0.4

Delta Part Number: ASD-CAEN1003, ASD-CAEN1005

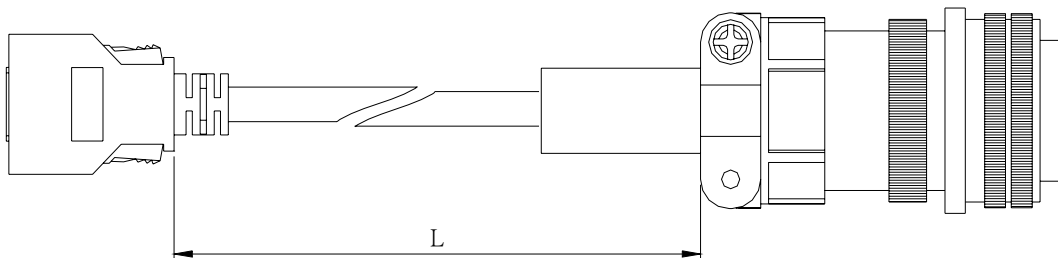

Title	Part No.	Straight	L	
			mm	inch
1	ASD-CAEN1003	MS 3106-20-29S	3000 ± 10	118 ± 0.4
2	ASD-CAEN1005	MS 3106-20-29S	5000 ± 10	197 ± 0.4

■ **I/O Signal Connector (CN1)**

Delta Part Number: ASD-CN5C0050

Vendor Name	Vendor P/N
3M TAIWAN LTD	10150-3000PE
3M TAIWAN LTD	10350-52A0-008

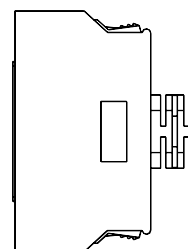

Appendix A Accessories | ASDA-A&A+ Series

■ **Communication Cable between Drive and Computer (for PC)**

Delta Part Number: ASD-CARS0003

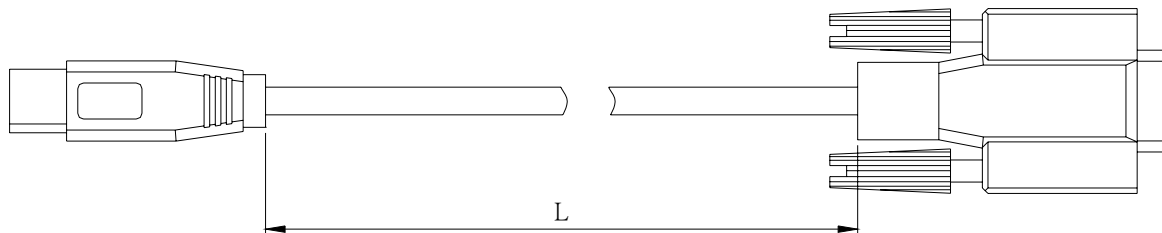

Title	Part No.	L	
		mm	inch
1	ASD-CARS0003	3000 ± 10	118 ± 0.4

■ **Terminal Block Module**

Delta Part Number: ASD-BM-50A

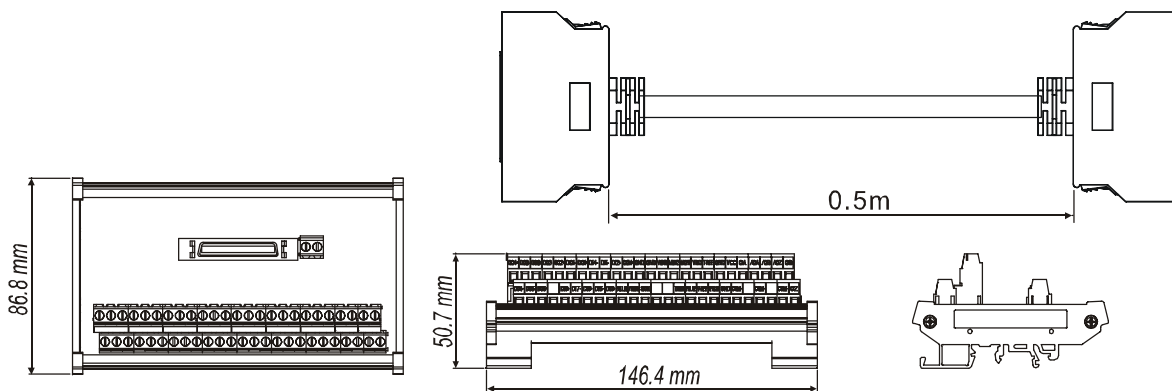

Appendix A Accessories | ASDA-A&A+ Series**■ Servo Drive, Servo Motor and Accessories Combinations****100W Servo Drive and 100W Low Inertia Servo Motor**

Servo Drive	ASD-A0121LA			
Low Inertia Servo Motor	ASMT-01L250A□		ASMT-01L250B□	
Cable	Without Brake		With Brake	
	3M	5M	3M	5M
	Motor Power Cable ASD-CAPW0003	Motor Power Cable ASD-CAPW0005	Motor Power Cable ASD-CAPW0103	Motor Power Cable ASD-CAPW0105
	Encoder Cable ASD-CAEN0003	Encoder Cable ASD-CAEN0005	Encoder Cable ASD-CAEN0003	Encoder Cable ASD-CAEN0005
Connector	Power Connector ASD-CAPW0000		Power Connector ASD-CAPW0100	
	Encoder Connector ASD-CAEN0000			

200W Servo Drive and 200W Low Inertia Servo Motor

Servo Drive	ASD-A0221LA			
Low Inertia Servo Motor	ASMT-02L250A□		ASMT-02L250B□	
Cable	Without Brake		With Brake	
	3M	5M	3M	5M
	Motor Power Cable ASD-CAPW0003	Motor Power Cable ASD-CAPW0005	Motor Power Cable ASD-CAPW0103	Motor Power Cable ASD-CAPW0105
	Encoder Cable ASD-CAEN0003	Encoder Cable ASD-CAEN0005	Encoder Cable ASD-CAEN0003	Encoder Cable ASD-CAEN0005
Connector	Power Connector ASD-CAPW0000		Power Connector ASD-CAPW0100	
	Encoder Connector ASD-CAEN0000			

400W Servo Drive and 400W Low Inertia Servo Motor

Servo Drive	ASD-A0421LA			
Low Inertia Servo Motor	ASMT-04L250A□		ASMT-04L250B□	
Cable	Without Brake		With Brake	
	3M	5M	3M	5M
	Motor Power Cable ASD-CAPW0003	Motor Power Cable ASD-CAPW0005	Motor Power Cable ASD-CAPW0103	Motor Power Cable ASD-CAPW0105
	Encoder Cable ASD-CAEN0003	Encoder Cable ASD-CAEN0005	Encoder Cable ASD-CAEN0003	Encoder Cable ASD-CAEN0005
Connector	Power Connector ASD-CAPW0000		Power Connector ASD-CAPW0100	
	Encoder Connector ASD-CAEN0000			

Appendix A Accessories | ASDA-A&A+ Series**750W Servo Drive and 750W Low Inertia Servo Motor**

Servo Drive	ASD-A0721LA			
Low Inertia Servo Motor	ASMT-07L250A□		ASMT-07L250B□	
Cable	Without Brake		With Brake	
	3M	5M	3M	5M
	Motor Power Cable ASD-CAPW0003	Motor Power Cable ASD-CAPW0005	Motor Power Cable ASD-CAPW0103	Motor Power Cable ASD-CAPW0105
	Encoder Cable ASD-CAEN0003	Encoder Cable ASD-CAEN0005	Encoder Cable ASD-CAEN0003	Encoder Cable ASD-CAEN0005
Connector	Power Connector ASD-CAPW0000		Power Connector ASD-CAPW0100	
	Encoder Connector ASD-CAEN0000			

1kW Servo Drive and 1kW Low Inertia Servo Motor

Servo Drive	ASD-A1021LA			
Low Inertia Servo Motor	ASMT-10L250A□		ASMT-10L250B□	
Cable	Without Brake		With Brake	
	3M	5M	3M	5M
	Motor Power Cable ASD-CAPW1003	Motor Power Cable ASD-CAPW1005	Motor Power Cable ASD-CAPW1103	Motor Power Cable ASD-CAPW1105
	Encoder Cable ASD-CAEN1003	Encoder Cable ASD-CAEN1005	Encoder Cable ASD-CAEN1003	Encoder Cable ASD-CAEN1005
Connector	Power Connector ASD-CAPW1000			
	Encoder Connector ASD-CAEN1000			

1kW Servo Drive and 1kW Medium Inertia Servo Motor

Servo Drive	ASD-A1021MA			
Medium inertia Servo Motor	ASMT-10M250A□		ASMT-10M250B□	
Cable	Without Brake		With Brake	
	3M	5M	3M	5M
	Motor Power Cable ASD-CAPW1003	Motor Power Cable ASD-CAPW1005	Motor Power Cable ASD-CAPW1103	Motor Power Cable ASD-CAPW1105
	Encoder Cable ASD-CAEN1003	Encoder Cable ASD-CAEN1005	Encoder Cable ASD-CAEN1003	Encoder Cable ASD-CAEN1005
Connector	Power Connector ASD-CAPW1000			
	Encoder Connector ASD-CAEN1000			

Appendix A Accessories | ASDA-A&A+ Series**1.5kW Servo Drive and 1.5kW Medium Inertia Servo Motor**

Servo Drive	ASD-A1521MA			
Medium inertia Servo Motor	ASMT-15M250A□		ASMT-15M250B□	
Cable	Without Brake		With Brake	
	3M	5M	3M	5M
	Motor Power Cable ASD-CAPW1003	Motor Power Cable ASD-CAPW1005	Motor Power Cable ASD-CAPW1103	Motor Power Cable ASD-CAPW1105
	Encoder Cable ASD-CAEN1003	Encoder Cable ASD-CAEN1005	Encoder Cable ASD-CAEN1003	Encoder Cable ASD-CAEN1005
Connector	Power Connector ASD-CAPW1000			
	Encoder Connector ASD-CAEN1000			

2kW Servo Drive and 2kW Low Inertia Servo Motor

Servo Drive	ASD-A2023LA			
Low Inertia Servo Motor	ASMT-20L250A□		ASMT-20L250B□	
Cable	Without Brake		With Brake	
	3M	5M	3M	5M
	Motor Power Cable ASD-CAPW1203	Motor Power Cable ASD-CAPW1205	Motor Power Cable ASD-CAPW1303	Motor Power Cable ASD-CAPW1305
	Encoder Cable ASD-CAEN1003	Encoder Cable ASD-CAEN1005	Encoder Cable ASD-CAEN1003	Encoder Cable ASD-CAEN1005
Connector	Power Connector ASD-CAPW1000			
	Encoder Connector ASD-CAEN1000			

2kW Servo Drive and 2kW Medium Inertia Servo Motor

Servo Drive	ASD-A2023MA			
Medium inertia Servo Motor	ASMT-20M250A□		ASMT-20M250B□	
Cable	Without Brake		With Brake	
	3M	5M	3M	5M
	Motor Power Cable ASD-CAPW2203	Motor Power Cable ASD-CAPW2205	Motor Power Cable ASD-CAPW2303	Motor Power Cable ASD-CAPW2305
	Encoder Cable ASD-CAEN1003	Encoder Cable ASD-CAEN1005	Encoder Cable ASD-CAEN1003	Encoder Cable ASD-CAEN1005
Connector	Power Connector ASD-CAPW2000			
	Encoder Connector ASD-CAEN1000			

Appendix A Accessories | ASDA-A&A+ Series**3kW Servo Drive and 3kW Low Inertia Servo Motor**

Servo Drive	ASD-A3023LA			
Low Inertia Servo Motor	ASMT-30L250A□		ASMT-30L250B□	
Cable	Without Brake		With Brake	
	3M	5M	3M	5M
	Motor Power Cable ASD-CAPW1203	Motor Power Cable ASD-CAPW1205	Motor Power Cable ASD-CAPW1303	Motor Power Cable ASD-CAPW1305
	Encoder Cable ASD-CAEN1003	Encoder Cable ASD-CAEN1005	Encoder Cable ASD-CAEN1003	Encoder Cable ASD-CAEN1005
Connector	Power Connector ASD-CAPW1000			
	Encoder Connector ASD-CAEN1000			

3kW Servo Drive and 3kW Medium Inertia Servo Motor

Servo Drive	ASD-A3023MA			
Medium inertia Servo Motor	ASMT-30M250A□		ASMT-30M250B□	
Cable	Without Brake		With Brake	
	3M	5M	3M	5M
	Motor Power Cable ASD-CAPW2203	Motor Power Cable ASD-CAPW2205	Motor Power Cable ASD-CAPW2303	Motor Power Cable ASD-CAPW2305
	Encoder Cable ASD-CAEN1003	Encoder Cable ASD-CAEN1005	Encoder Cable ASD-CAEN1003	Encoder Cable ASD-CAEN1005
Connector	Power Connector ASD-CAPW2000			
	Encoder Connector ASD-CAEN1000			

4.5kW Servo Drive and 3kW High / Medium Inertia Servo Motor

Servo Drive	ASD-A4523-B			
Medium / High Inertia Servo Motor	ECMA-F21830□S			
Cable	Without Brake		With Brake	
	3M	5M	3M	5M
	Motor Power Cable ASD-CAPW2203	Motor Power Cable ASD-CAPW2205	Motor Power Cable ASD-CAPW2303	Motor Power Cable ASD-CAPW2305
	Encoder Cable ASD-CAEN1003	Encoder Cable ASD-CAEN1005	Encoder Cable ASD-CAEN1003	Encoder Cable ASD-CAEN1005
Connector	Power Connector ASD-CAPW2000			
	Encoder Connector ASD-CAEN1000			

Appendix A Accessories | ASDA-A&A+ Series**4.5kW Servo Drive and 4.5kW High / Medium Inertia Servo Motor**

Servo Drive	ASD-A4523-B			
Medium / High Inertia Servo Motor	ECMA-F21845□S			
Cable	Without Brake		With Brake	
	3M	5M	3M	5M
	Motor Power Cable ASD-CAPW3203	Motor Power Cable ASD-CAPW3205	Motor Power Cable ASD-CAPW3303	Motor Power Cable ASD-CAPW3305
	Encoder Cable ASD-CAEN1003	Encoder Cable ASD-CAEN1005	Encoder Cable ASD-CAEN1003	Encoder Cable ASD-CAEN1005
Connector	Power Connector ASD-CAPW2000			
	Encoder Connector ASD-CAEN1000			

5.5kW Servo Drive and 5.5kW High / Medium Inertia Servo Motor

Servo Drive	ASD-A5523-B		
Medium / High Inertia Servo Motor	ECMA-F21855□3		
Connector	Power Connector ASD-CAPW2000		
	Encoder Connector ASD-CAEN1000		
	Brake Connector ASD-CNBR1000		

7.5kW Servo Drive and 7.5kW High / Medium Inertia Servo Motor

Servo Drive	ASD-A7523-B		
Medium / High Inertia Servo Motor	ECMA-F21875□3		
Connector	Power Connector ASD-CAPW2000		
	Encoder Connector ASD-CAEN1000		
	Brake Connector ASD-CNBR1000		

Other Accessories

Other Accessories (for ASDA-A and ASDA-A+ series all models)	
Description	Delta Part Number
50Pin I/O signal connector (CN1)	ASD-CN5C0050
Communication cable, for PC, connecting a ASDA-A&A+ servo drive to a PC	ASD-CARS0003
Terminal Block Module	ASD-BM-50A

Appendix A Accessories | ASDA-A&A+ Series**■ Regenerative Resistor Specifications****ASDA-A Series Servo Drive**

Servo Drive (kW)	Recommended Specifications for Built-in Regenerative Resistor		Recommended Specifications for External Regenerative Resistor	Min. Allowable Resistance (Ohm)
	Resistance (Ohm) (parameter P1-52)	Capacity (Watt) (parameter P1-53)		
0.1	40Ω	60W	60Ω 100W	40Ω
0.2	40Ω	60W	60Ω 200W	40Ω
0.4	40Ω	60W	30Ω 400W	20Ω
0.75	40Ω	60W	30Ω 750W	20Ω
1.0	40Ω	60W	30Ω 1kW	20Ω
1.5	40Ω	60W	30Ω 1kW	20Ω
2.0	20Ω	120W	15Ω 1kW	10Ω
3.0	20Ω	120W	15Ω 1kW	10Ω

ASDA-A+ Series Servo Drive

Servo Drive (kW)	Recommended Specifications for Built-in Regenerative Resistor		Recommended Specifications for External Regenerative Resistor	Min. Allowable Resistance (Ohm)
	Resistance (Ohm) (parameter P1-52)	Capacity (Watt) (parameter P1-53)		
4.5	20Ω	100 W	12Ω 4.5kW	10Ω
5.5*	-	-	8Ω 5.5kW	8Ω
7.5*	-	-	8Ω 7.5kW	8Ω

*: There is no built-in regenerative resistor for 5.5kW and 7.5kW Servo Drive.

 **NOTE**

- 1) When the fault, ALE05 (Regeneration Error) occurs, please increase the regenerative resistor capacity.
- 2) When combining multiple small-capacity regenerative resistors in parallel to increase the regenerative resistor capacity, make sure that the total resistance value of the regenerative resistors can't be less than the minimum allowable resistance listed in the above table.

Appendix A Accessories | ASDA-A&A+ Series

This page intentionally left blank.

Appendix B Molded-case Circuit Breaker, Fuse Current and EMI Filters

■ Molded-case Circuit Breaker and Fuse Current Recommended Value



➤ *Caution: Please use molded-case circuit breaker and fuse which are recognized by and comply with the UL or CSA standards.*

ASDA-A Series Servo Drive

Model Name	Breaker	Fuse (Class T)
Operation Mode	General	General
ASD-A0121LA	5A	5A
ASD-A0221LA	6A	6A
ASD-A0421LA	10A	10A
ASD-A0721LA	10A	20A
ASD-A1021LA	15A	25A
ASD-A1021MA	15A	20A
ASD-A1521LA	20A	40A
ASD-A1521MA	20A	40A
ASD-A2023LA	30A	50A
ASD-A2023MA	30A	50A
ASD-A3023LA	30A	70A
ASD-A3023MA	30A	70A

ASDA-A+ Series Servo Drive

Model Name	Breaker	Fuse
Operation Mode	General	General
ASD-A4523-B	50A	120A
ASD-A5523-B	50A	120A
ASD-A7523-B	50A	120A

Appendix B Accessories | ASDA-A&A+ Series

■ AC Servo Drive - EMI Filter Cross Reference

ASDA-A Series Servo Drive

Item	Power	Servo Drive Model	Recommended EMI Filter	FootPrint
1	100W	ASD-A0121LA	16DRT1W3S (1-phase)	N
			10TDT1W4C (3-phase)	N
2	200W	ASD-A0221LA	16DRT1W3S (1-phase)	N
			10TDT1W4C (3-phase)	N
3	400W	ASD-A0421LA	16DRT1W3S (1-phase)	N
			10TDT1W4C (3-phase)	N
4	750W	ASD-A0721LA	16DRT1W3S (1-phase)	N
			10TDT1W4C (3-phase)	N
5	1000W	ASD-A1021LA	16DRT1W3S (1-phase)	N
			10TDT1W4C (3-phase)	N
6	1500W	ASD-A1521MA	16DRT1W3S (1-phase)	N
			10TDT1W4C (3-phase)	N
7	2000W	ASD-A2023LA	26TDT1W4C (3-phase)	N
8	2000W	ASD-A2023MA	26TDT1W4C (3-phase)	N
9	3000W	ASD-A3023LA	26TDT1W4C (3-phase)	N
10	3000W	ASD-A3023MA	26TDT1W4C (3-phase)	N

ASDA-A+ Series Servo Drive

Item	Power	Servo Drive Model	Recommended EMI Filter	FootPrint
1	4500W	ASD-A4523-B	20TDT1W4D (3-phase)	N
2	5500W	ASD-A5523-B	RF075M43BA (3-phase)	Y
3	7500W	ASD-A7523-B	RF075M43BA (3-phase)	Y

Installation

All electrical equipment, including AC servo drives, will generate high-frequency/low-frequency noise and will interfere with peripheral equipment by radiation or conduction when in operation. By using an EMI filter with correct installation, much of the interference can be eliminated. It is recommended to use Delta's EMI filter to have the best interference elimination performance.

We assure that it can comply with following rules when AC servo drive and EMI filter are installed and wired according to user manual:

- EN61000-6-4 (2001)
- EN61800-3 (2004) PDS of category C2
- EN55011+A2 (2007) Class A Group 1

Appendix B Accessories | ASDA-A&A+ Series

General Precaution

To ensure the best interference elimination performance when using Delta's EMI filter, please follow the guidelines in this user manual to perform wiring and/or installation. In addition, please also observe the following precautions:

- EMI filter and AC servo drive should be installed on the same metal plate.
- Please install AC servo drive on same footprint with EMI filter or install EMI filter as close as possible to the AC servo drive.
- All wiring should be as short as possible.
- Metal plate should be grounded.
- The cover of EMI filter and AC servo drive or grounding should be fixed on the metal plate and the contact area should be as large as possible.

Choose Suitable Motor Cable and Precautions

Improper installation and choice of motor cable will affect the performance of EMI filter. Be sure to observe the following precautions when selecting motor cable.

- Use the cable with shielding (double shielding is the best).
- The shielding on both ends of the motor cable should be grounded with the minimum length and maximum contact area.
- Remove any paint on metal saddle for good ground contact with the plate and shielding (Please refer to Figure 1 on page B-3).
- The connection between the metal saddle and the shielding on both ends of the motor cable should be correct and well installed. Please refer to Figure 2 on page B-4 for correct wiring method.

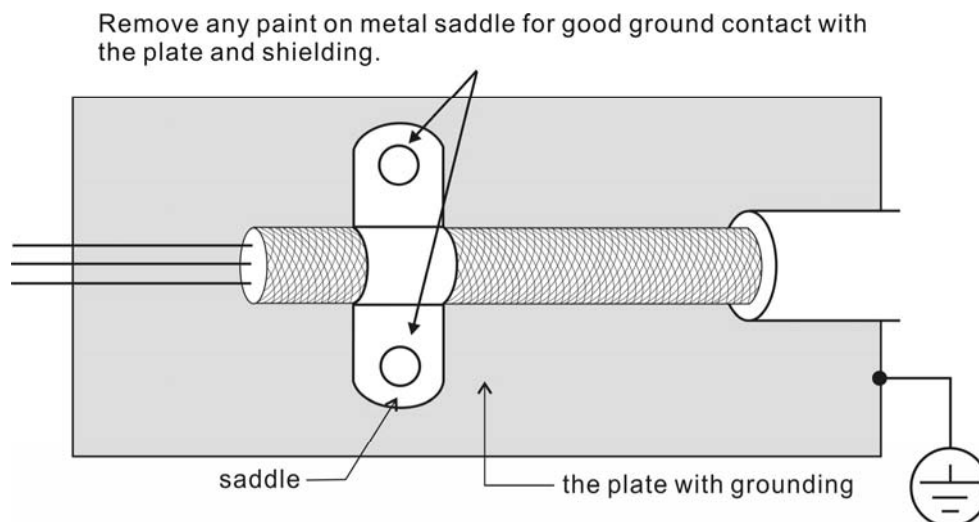
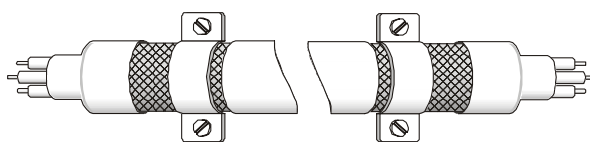
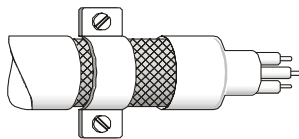

Figure 1

Appendix B Accessories | ASDA-A&A+ Series



Saddle on both ends



Saddle on one end

Figure 2

Dimensions

Delta Part Number: 08TDT1W4S

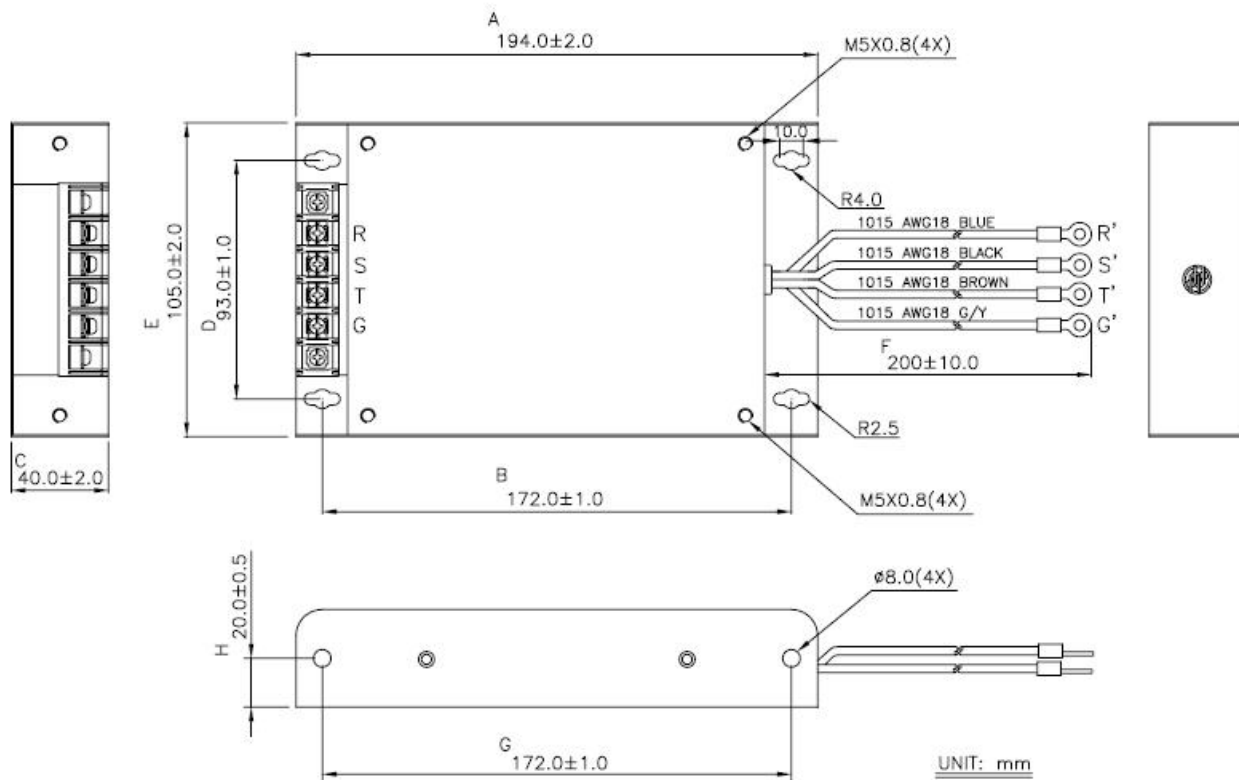

Appendix B Accessories | ASDA-A&A+ Series

Delta Part Number: 10TDT1W4C

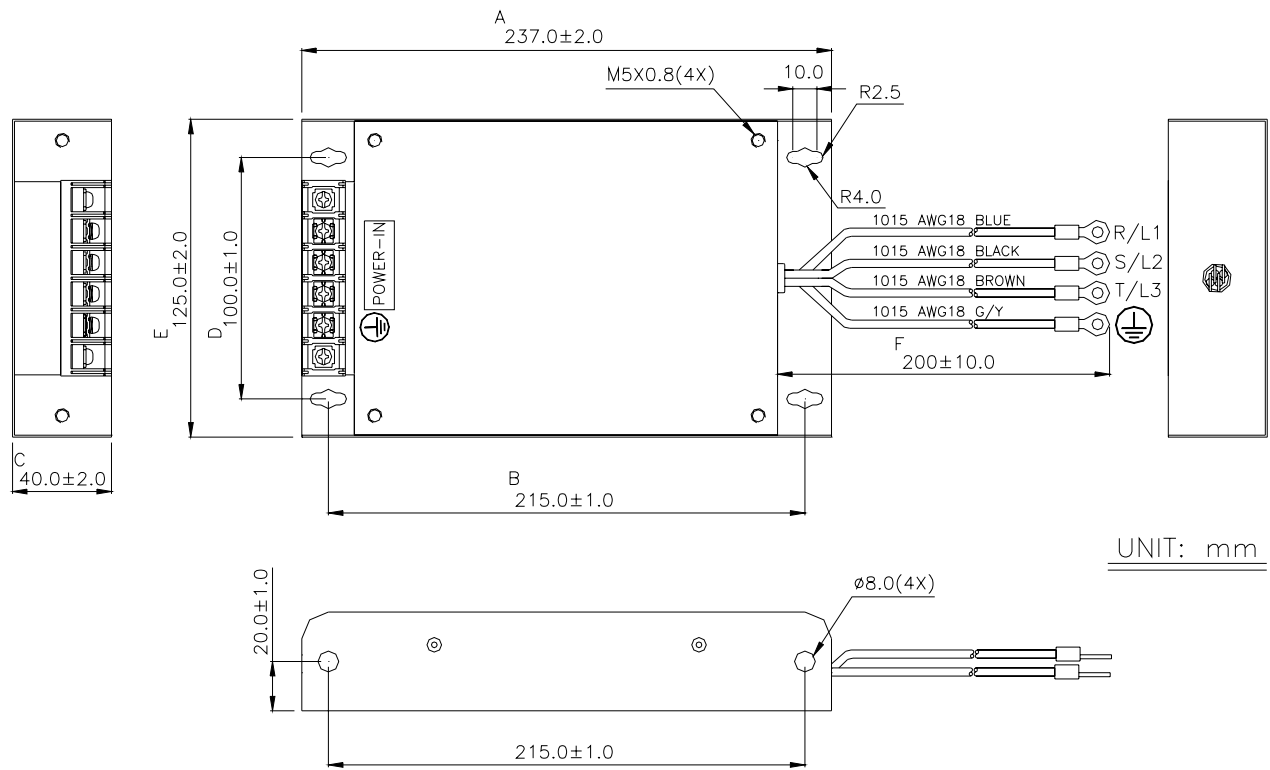

Delta Part Number: 16DRT1W3S

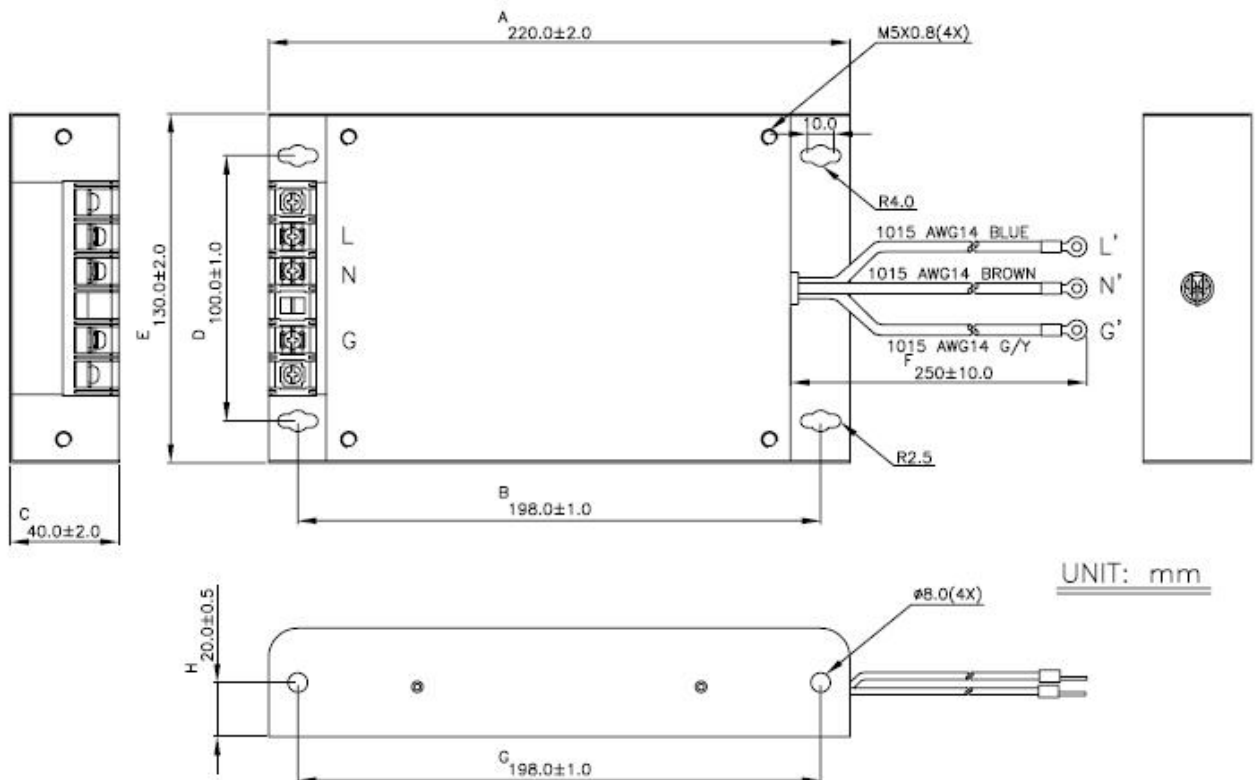

Appendix B Accessories | ASDA-A&A+ Series

Delta Part Number: 20TDT1W4D

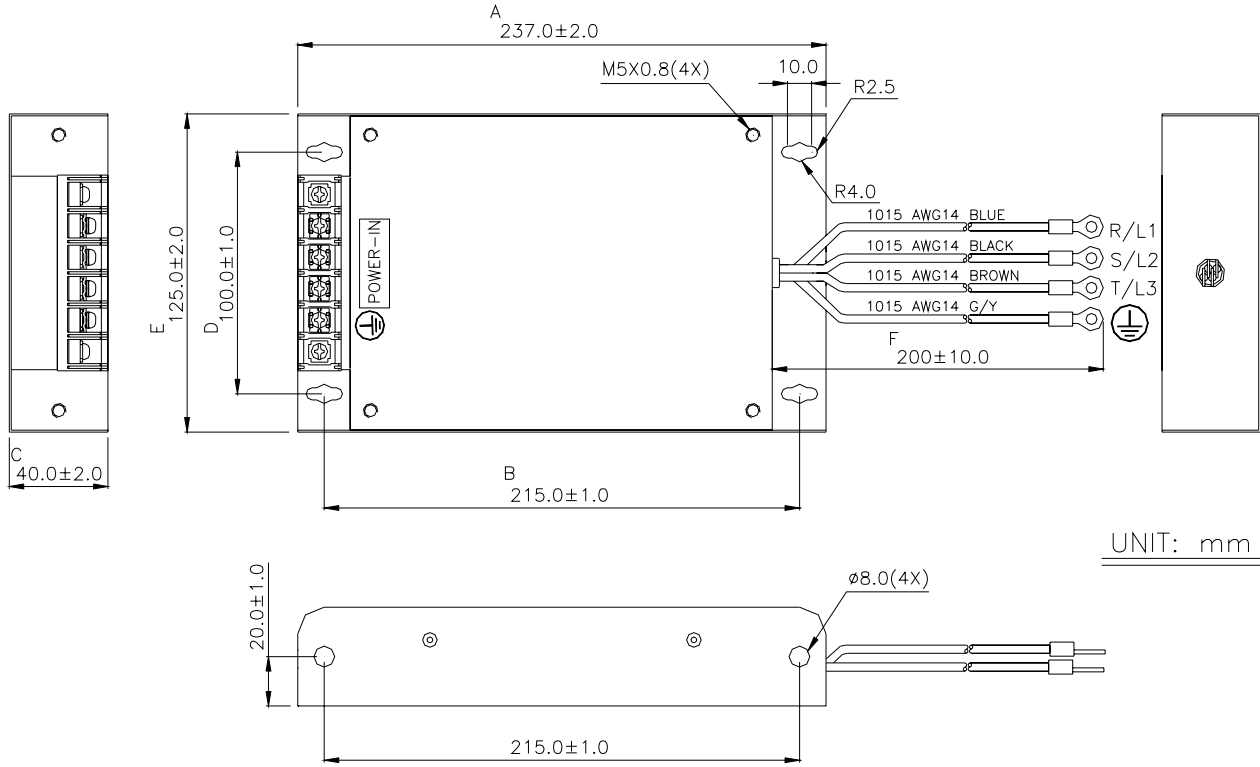

Delta Part Number: 26TDT1W4C

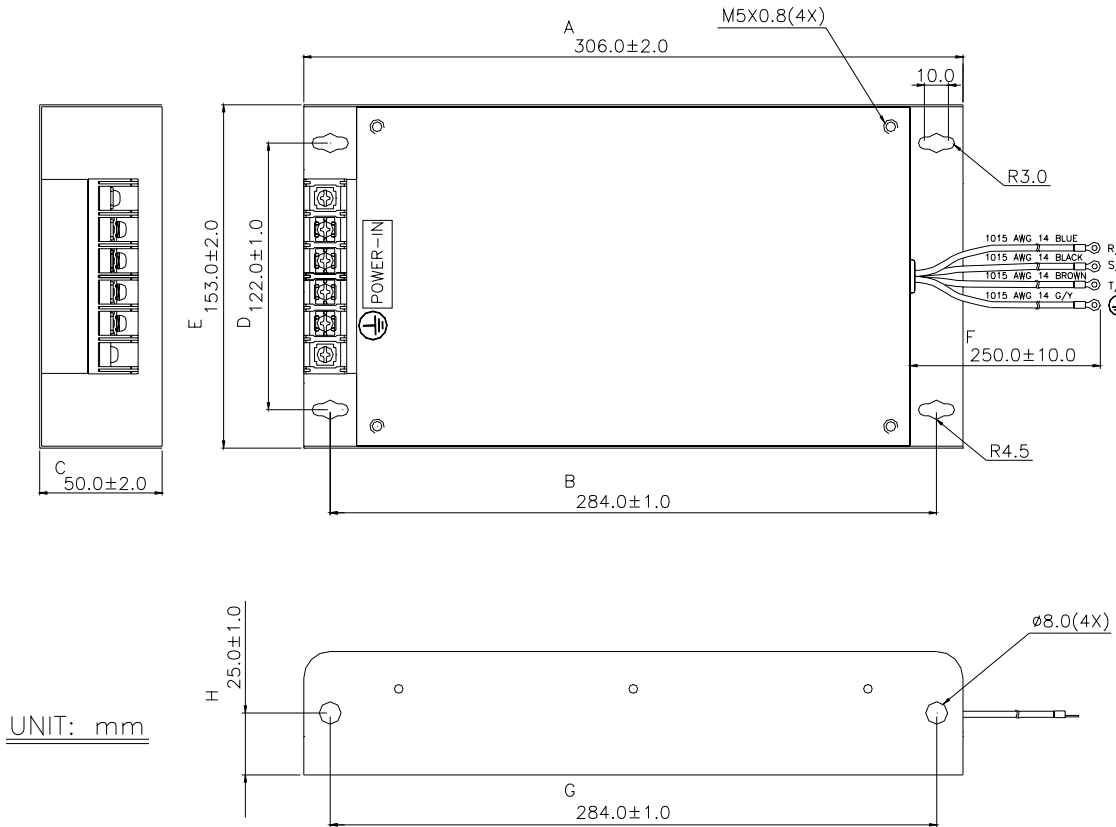

Appendix B Accessories | ASDA-A&A+ Series

Delta Part Number: RF075M43BA

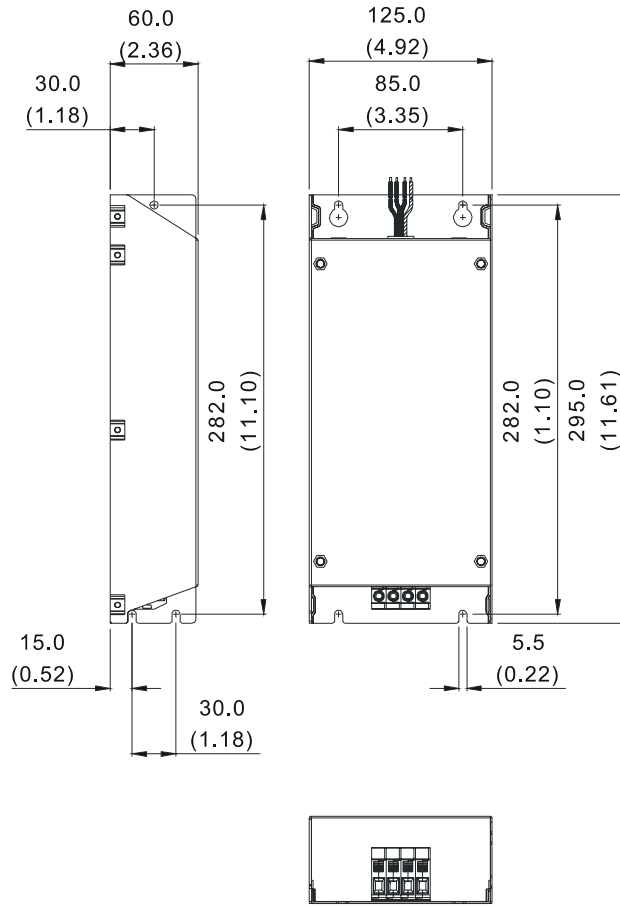

Appendix B Accessories | ASDA-A&A+ Series

This page intentionally left blank.